

WELCH-ILMVAC

OWNER'S MANUAL
FOR
DRY VACUUM PUMP
MODELS: 2562C-02 / 2562C-50 / 2562Z-02



Warning
Not recommended for pumping acid, base or organic vapors or gases.



Warning
Be sure to properly identify intake and discharge before using pump.

Welch-Ilmvac
5621 W. Howard Street
Niles, IL 60714
Phone: (847) 676-8800 (Technical Support)
Fax: (847) 677-8606
E-Mail: gdwelchvacuum@gardnerdenver.com
Web-Page: www.welchvacuum.com

Part No. 642803A
Printed in USA

TABLE OF CONTENTS

	Page No.
1. Safety Information	3
2. Installation	5
3. Operation	8
4. Maintenance	8
5. Trouble Shooting	9
6. Specifications	9
7. Dimensional Drawings	10
8. Application Information	11
9. Exploded Parts List	13
10. Warranty	14

INSTRUCTION
WARNING AND CAUTION
PLEASE READ BEFORE OPERATION

While reading your manual, please pay close attention to areas labeled:
WARNING AND CAUTION.
The description of each is found below.

WARNING
Warnings are given where failure to observe instruction could result in injury or death to people.

CAUTION
Cautions are found where failure to observe the instruction could result in damage to the equipment, associated equipment and process.

These units conform to the SI International system of units of measurement.

The following symbols (with recommendation of IEC1010) of warning will be found on the pump.



Caution - Refer to accompanying documents



Caution - Risk of electrical shock



Caution - Hot surface

WARNING
Motor includes a self resetting thermal cutout and the pump could restart without actuation under fault condition.

Section 1: SAFETY INFORMATION

- I.10 CAUTION: To prevent injury...
- I.11 Never operate this product if it has a damaged cord or plug. If it is not working properly, has been dropped, damaged or has fallen into water, please return the product to a Welch service center for examination and repair.
- I.12 Keep the cord away from the heated surfaces.
- I.13 Never block any air openings or place it on a soft surface where the openings may be blocked. The air openings are for ventilation of the motor inside the housing. Keep all air openings free of lint, dirt and other foreign objects.
- I.14 The PTFE pump is thermally protected and can automatically restart when the protector resets. Always disconnect power source before servicing.
- I.15 Wear safety glasses or goggles when operating this product.
- I.16 Use only in well ventilated areas. The motor is fan cooled enclosed in a shell.



WARNING

Do not operate the pumps in an atmosphere containing flammable or explosive gases/vapors.



WARNING

Never block the exhaust port. If the exhaust is blocked, pressure will build-up in the pump with the potential of the pump head bursting and causing possible injury to personnel in the area.

- I.17 All electrical products generate heat. To avoid serious burns never touch unit during or immediately after operation.
- I.18 Be sure to properly identify intake and discharge before using pump. See Section II-5.
- I.20 CAUTION: To reduce risk of electrical shock...
- I.21 Do not disassemble. Disassembly or attempted repairs if accomplished incorrectly can create electrical shock hazard. Refer servicing to qualified service agencies only: Call (847) 676-8800.
- I.22 Unit is supplied with a three pronged plug. Be sure to connect pump to a properly grounded outlet only.
- I.23 WARNING: To reduce risk of electrocution...
- I.24 Do not use this product in or near area where it can fall or be pulled into water or other liquids.
- I.25 Do not reach for this product if it has fallen into liquid. Unplug immediately.
- I.26 Never operate this product outdoors in the rain or in a wet area.
- I.27 DANGER: To reduce risk of explosion or fire...
- I.28 Do not use this pump near explosive atmospheres or where aerosol (spray) products are being used.
- I.29 Do not use this product near flames.



WARNING

Failure to observe the above safety precautions could result in severe bodily injury, including death in extreme cases.

Section 2: INSTALLATION

2.10 Introduction

This manual has been compiled not only for the care and maintenance of the Welch Dry Vacuum Pump now in your possession, but as a helpful reference and guide to prevent many problems which can occur if used improperly.

2.11 Unpacking

Carefully remove the Dry Vacuum pump from the shipping carton. Preserve all paperwork for future reference. If damage has occurred from shipment a claim must be filed with the carrier immediately; preserve the shipping carton for inspection by the carrier. If you are required to communicate with your dealer or Welch Vacuum be sure to include your order numbers for quick identification. Do not return the system to the factory without first calling for a returned goods number. Call (847) 676-8800.

2.12 Pump Mounting

Rubber feet are attached to the pump. Rubber feet are excellent for applications involving a semi-flexible surface such as a bench top; they help to isolate noise and eliminate creeping. This pump should be mounted on a horizontal plane.

2.13 Pump Location and Environmental Condition

The pressure/vacuum pump should be located in a clean, dry and well-ventilated area. Do not block the ventilation ports located on the motor housing. The pump should be placed where the surrounding temperature remains between 10°C and 40°C (50°F and 104°F). Always check to insure the location choice is protected from direct or indirect moisture contact. Welch recommends that the pump be installed at the highest point within the system to prevent possible water condensate from entering the pump. The pump should be located as closely to its system in order to utilize it most efficiently.



WARNING

Do not pump flammable or explosive gases or vapors or operate this pump in an atmosphere containing flammable or explosive gases or vapors.

2.14 Intake and discharge provisions

The intake provision is a hose barb which accepts 3/8" ID Hose (Welch part no. 331030-5 is a 5 ft length of 3/8" ID vacuum hose). A silencer is supplied for the exhaust.



WARNING

Bursting Hazard- use on exhaust port the silencer or air handling parts suitable for pressures not less than 100 PSIG.

Be sure to call Welch technical service prior to start-up at (847) 676-8800 if you have any questions.

2.20 Electrical Power

2.21 Power Source Review

Review the power source and the voltage rating on the units serial number tag to be sure they agree in voltage, phase and frequency. Serious damage may occur to the system if it is connected to an improper voltage. All Welch systems must be grounded. Grounding reduces the risk of electric shock in the event of an electrical short circuit. The plug must be plugged into an outlet properly grounded. Consult your local electrical codes if you have doubts.

2.22 Overload Protection

The motor manufacturer makes motor thermal overload protection available as an aid to minimize motor failure. Overload protection is a standard feature on both 50/60Hz single-phase motors. The motors have automatic overload protection. Automatic reset protection is designed to reset itself after a predetermined cooling period. If the fault to the drive remains unaltered, the motor will cycle on and off until fault is corrected.

2.23 Identification Symbols:

○ Power Off | Power On

2.24 Grounding Instructions

This product should be grounded. In the event of an electrical short circuit, grounding reduces the risk of electric shock by providing an escape wire for the electric current. This product is equipped with a cord having a grounding wire with a grounding plug. The plug must be plugged into an outlet that is properly installed and grounded in accordance with all local codes and ordinances. This adapter shown in Figure B and Figure C is not acceptable in Canada.

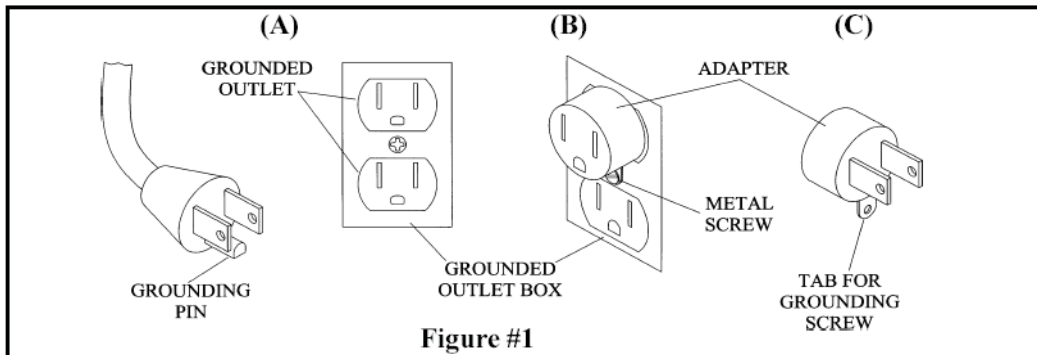

DANGER
Improper installation of the grounding plug can result in a risk of electrical shock.

If repair or replacement of the cord or plug is necessary, do not connect the grounding wire to either flat blade terminal. The wire with insulation having an outer surface that is green with or without yellow stripes is the grounding wire. Check with a qualified electrician or serviceman if the grounding instructions are not completely understood, or if in doubt as to whether the product is properly grounded. Do not modify the plug provided; if it will not fit the outlet, have the proper outlet installed by a qualified electrician.

This product is for use on a nominal 120V circuit, and has a grounding plug that looks like the plug illustrated in Sketch A in Figure #1. A temporary adapter, which looks like the adapter illustrated in sketches B and C, may be used to connect this plug to a 2-pole receptacle as shown in sketch B if a properly grounded outlet is not available. The temporary adapter should be used only until a properly grounded outlet (Sketch A) can be installed by a qualified electrician. The green colored rigid ear, lug, etc. extending from the adapter must be connected to a permanent ground such as a properly grounded outlet box cover. Whenever the adapter is used, it must be held in place by a metal screw.

2.25 Extension Cords

If necessary to use an extension cord, use a 3-wire extension cord that has a 3-blade grounding plug, and a 3-slot receptacle that will accept the plug on the product. Make certain your extension cord is in good condition. Make certain your extension cord wire size is not less than 18 gauge for 25 feet, 16 gauge for 50 feet, and 14 gauge for 100 feet. An undersized cord will cause a drop in line voltage resulting in loss of power and overheating. If in doubt, use the next heavier cord. The smaller the gauge number, the heavier the cord.

2.26 Vacuum Connections

All Dry Vacuum Pumps come with intake and discharge hose barbs which accept 3/8" ID rubber pressure/vacuum hose. Hose clamps should be used to hold the hose in place. Since all six models operate in the viscous flow range, the small diameter of the hose will generate minimal conductance loss. For best results, Welch recommends the length of the tubing between the pump and the chamber be kept as small as possible.

2.27 Vacuum Gauges

Typically in the rough vacuum range, a dial vacuum gauge is used to measure pressure in mm of Hg or inches of Hg. The dial vacuum gauge gives negative pressure – that is pressure below atmospheric. The reference point for the vacuum gauge is atmospheric pressure. Please keep in mind that atmospheric pressure tends to vary from day to day. As a result of variability, the dial vacuum gauge will indicate slightly different maximum vacuum readings from day to day.

2.30 Traps

2.30a The need for a Trap

The pumps will handle humid air. All wetted aluminum parts are treated for corrosion protection from moisture. All other wetted parts are stainless steel. If there is a chance liquid may be drawn from the process under evacuation, Welch recommends a liquid trap be placed between the process and the pump. A simple liquid trap is a filtering flask.

When a heavy load of water vapor is evolved from the vacuum process, a cold trap is recommended to help prevent damage to the pump mechanism. The cold trap, immersed in a suitable Dewar flask, is installed so that the water vapor may come in contact with the surfaces of the trap and condense. Commonly used refrigerants are liquid nitrogen or dry ice and acetone or alcohol. Dry ice provides sufficient cooling to freeze out most heavy water vapor loads. A variety of cold traps are available from Welch.

The symptom of a high water vapor load is if you have droplets coming out of the exhaust port. If you see droplets of water, Welch recommends you use a cold trap to capture the water before entering the pump or dilute the water vapor stream by adding dry nitrogen to the gas flow. Please call our customer service department for additional information at (847) 676-8800.

2.30b The care of a Trap

When using a cold trap the refrigerant should be maintained at a high level in the flask to keep the trap at a uniformly low temperature. If the trap is re-warmed it may allow re-evaporation of the condensate. The refrigerant add tube on the liquid nitrogen trap should not be obstructed as the refrigerant boil-off can produce dangerously high pressures. If the trap becomes saturated it should be disconnected from the system, drained and cleaned. An increase in pressure in the vacuum system will normally indicate that the trap has become saturated. To clean the trap, remove the trap from the system and allow the trap to warm up and rinse off the condensate with a suitable solvent in a fume hood. Thoroughly clean and dry the trap before reinstalling into the system.

3.10 Starting Procedures

3.11 Starting a Welch Dry Vacuum Pump

Before attaching the pump to a system it is well to familiarize yourself with the function and action of the pressure vacuum pump that you have acquired. Review the power requirements as described in Section 2.6. Welch recommends running the pump for a few minutes to warm up before use. The warm-up improves the pump's ability to handle humid air.

3.12 Cleanliness

Take every precaution to prevent foreign particulates from entering the pump. Particulates will damage the pump's performance. If you find that particulates will come off the process during evacuation, a particle trap in the foreline will work. A simple, inexpensive trap may be made by placing glass wool in a glass or plastic tube. Screens must be inserted to hold the glass wool in place.



WARNING

The Pump is not recommended for pumping acid, base or organic vapors or gases. Serious damage to the pump will shorten the pump's service life. In addition, pumping flammable vapors or gases can lead to serious safety hazard leading to fire or explosion.

3.13 Leak Detection

The importance of eliminating all leaks in a vacuum system is obvious. The pump must remove this added volume of leaked gas to maintain the desired vacuum. Leaks for these pumps can be located by slightly pressuring the system and painting the suspected area with a thick soap solution. Escaping air will produce soap bubbles.

3.14 Operating Pressure Range

Model 2585 Dry Vacuum Pumps are designed to be run from atmospheric to their maximum vacuum level on the intake side. Consult the Specification Table in the back of this manual for the ratings for your specific model.

3.15 Shutdown Procedures

After use, Welch recommends the pump be run for about 2 minutes disconnected from the vacuum process. The air pumped through the mechanism will purge out water vapor or droplets of water condensate that may have formed on the inside of the pump. This purge of the pump mechanism helps prevent corrosion.

Section 4: MAINTENANCE

Welch dry pressure / vacuum units are 100% oil-free. The pump employs a non-lube piston and cylinder. No maintenance is necessary for the bearings. All bearings are sealed and permanently lubricated. Lubrication should not be attempted. The units are built for continuous duty operation with the quietness and durability of a diaphragm, but with piston pump performance.

Section 5: TROUBLESHOOTING

5.10 Vacuum Problems

Leakage, contamination and unusual outgassing are the general causes of problems with poor vacuum. To operate at maximum efficiency a system must be thoroughly clean. If the system is completely clean and free from leaks, and unwarranted vacuum problems still exist, the pump should be checked. A simple criterion for the condition of the pump is the determination of its maximum vacuum capability. This can be accomplished by blocking of the intake and reading the vacuum level on the gauge (See Section 2.8).

5.11 Troubleshooting Guide

Poor Pumping Speed	Poor Vacuum	Loud Unit	Possible Cause	Corrective Action
X	X	X	Damaged Valves	Replace flapper Valves
X	X	X	Debris in Valves	Remove debris and check for valve damage
X	X	X	Damaged Gasket	Replace Gasket
X	X	X	Loose Head Screw	Tighten Head Screw
X	X		Loose Fitting	Tighten Fitting

Section 6: SPECIFICATION

6.10 Pump Specifications

Model 2562	
Free Air Displacement	2.3 CFM @60Hz (65 L/min. @60Hz) 3.4 M ³ @50Hz (57 L/min. @50Hz)
Ultimate Pressure	7.5 Torr (10mbar)
Maximum Vacuum	29.6 In.Hg.
Motor Horsepower	1/3
Tubing	I.D. 3/8" (10mm)
Intake & Exhaust thread	3/8 NPT
Weight	16.5 lbs (7.5 Kg)

6.11 Pumping Speed Curves

Pumping Speed for 2562B-01

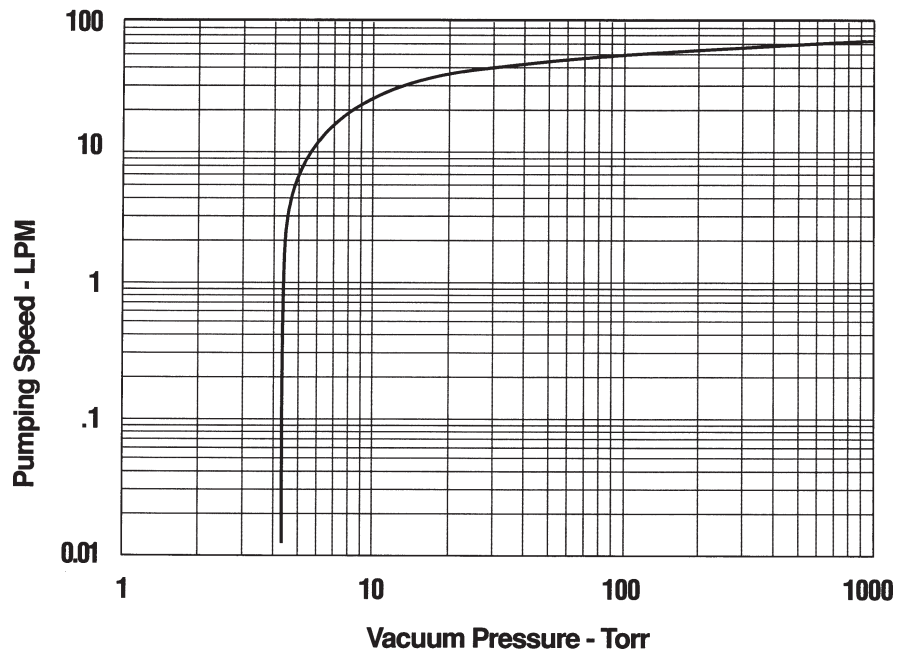

6.12 Dimensions Model 2562

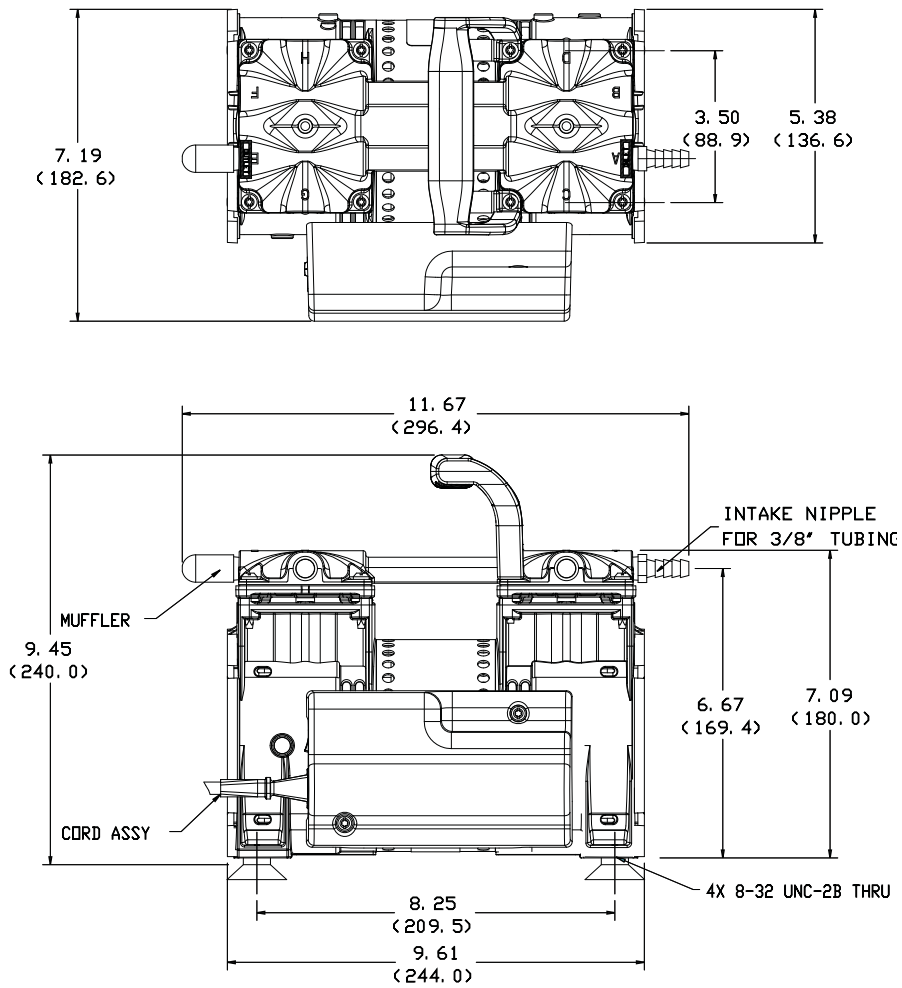

Section 7: APPLICATION INFORMATION

7.10 Vacuum System for Cell Harvesting:

- 2562C-02
- 2562Z-02
- 2562C-50 (includes trap & gauge)

7.11 System Components

2562C-02 230V, 50/60Hz	2562Z-02 230V, 50Hz	2562C-50 230v, 50Hz	Qty.	Part No.	Description
		*	1	61-3576	Jar Lid Intake, Machined
		*	1	61-5142	Needle Valve
		*	1	61-5148	Knob
		*	1	624280	Hose Barb Fitting
*			1	624282	Hose Barb Fitting
		*	1	66-0136	Hose Barb Fitting-Straight
		*	1	638788	Vacuum Gauge 0-30 InHg
		*	1	614913	Plastic Jar
		*	1	618345	Reducer Fitting
*	*	*	1	641255	Muffler
		*	1	61-9772	Jar Gasket

*Note 1: These parts are not available separately, but are supplied within the kits shown in last three columns.

7.12 Vacuum System for Cell Harvesting:

The vacuum system provides high throughput flow which allows up to 96+ sample system to be handled. The attached inlet trap is provided to inhibit the accidental ingestion of liquid into the pump.

Vacuum level is preset at 26"Hg when the inlet is plugged with a rubber stopper. The vacuum gauge provided allows to check the vacuum level - That is pressure below atmospheric. The reference point for the vacuum gauge is atmospheric pressure. Please keep in mind that atmospheric pressure tends to vary from day to day. As a result of this variability, the dial vacuum gauge will indicate slightly different maximum vacuum readings from day to day.

The preset vacuum level may be adjusted by opening or closing the orifice. A small leak through the orifice is provided to allow easy restart of the pump if you are turning off then immediately turning on the pump as is found with some cell harvesting applications.

By turning clockwise the screw located on top of the orifice, the vacuum level can be dropped to as low as 27.6"Hg. The deeper vacuum is particularly useful for removing sticky or viscous substance. If you close off the orifice, please keep in mind this will lead to restart problems if you are turning off then immediately turning on the pump. If you encounter a restart problem after closing the orifice, you will need to incorporate into your procedure bringing the cell harvester up to atmospheric prior to restarting of the pump.

7.13 Parts List and Exploded View for Pump Model 2562

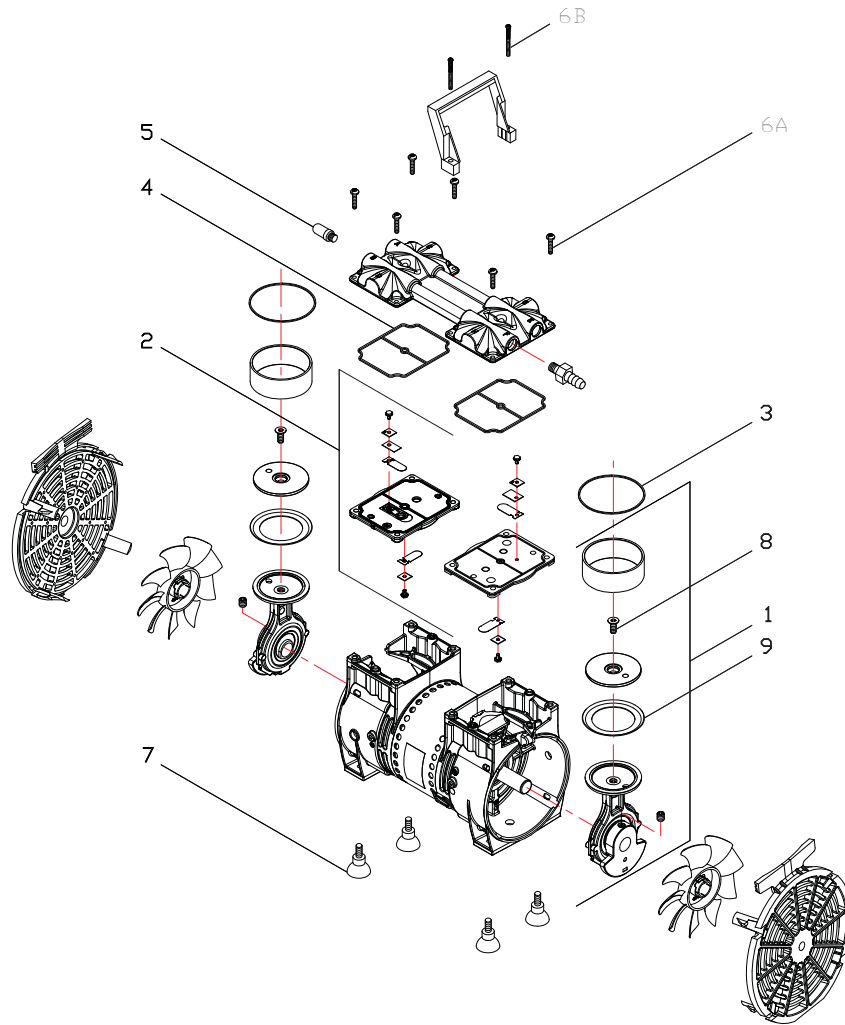

Item	Qty.	Part No.	Description	Service Kit 2567K-03	Seal Kit 2567K-04	Feet Kit 2500K-04	Muffler Kit 1412C
1	2	666544	Connecting Rod Ass'y	2	-	-	-
2	2	621755-502	Valve Plate Assembly	2	-	-	-
3	2	628071	Cylinder O-ring	2	2	-	-
4	2	623143	Valve Plate Gasket	2	2	-	-
5	1	641255	Exhaust Muffler	1	-	-	1
6A	6	625175	Head Screw	6	-	-	-
6B	2	625855	Handle Screw	-	-	-	-
7	4	624496	Suction Cup Feet	-	-	4	-
8	2	625180	Cup Retainer Screw	-	2	-	-
9	2	624490	Piston Cup	-	2	-	-

Warranty

This Welch Vacuum product is warranted to be free from defects in material and workmanship. This liability of Welch-IImvac under this warranty is limited to servicing, adjusting, repairing, or replacing any unit or component part which in the judgment of Welch-IImvac has not been misused, abused, or altered in any way or damaged by ingestion of foreign material causing impaired performance or rendering it inoperative. No other warranties are expressed or implied. The method of executing this warranty: servicing, adjusting, repairing, or replacing, shall be at the discretion of Welch-IImvac. Vacuum pumps that have been operated within a vacuum system, or other system, for any period, however short, will be repaired under this warranty rather than replaced.

The warranty is effective for one year from the date of original purchase when:

1. The warranty card has been completed and returned.
2. The product is returned to the factory or other designated service centers, freight prepaid.
3. The product in our judgment is defective through no action or fault of the user.

If the product has become defective through misuse, abuse, alteration, or ingestion of foreign material, repairs will be billed regardless of the age of the product. In this event, an estimate of the repair costs will be submitted and authorization of these charges will be required before the product is repaired and returned.

Welch-IImvac
5621 W. Howard Street
Niles, IL 60714
Phone: (847) 676-8800 (Technical Support)
Fax: (847) 677-8606
E-Mail: gdwelchvacuum@gardnerdenver.com
Web-Page: www.welchvacuum.com