

# HEPA/UV3 PCR Workstation and Cabinet

---

## *Installation and User Instructions*



---

**UVP, LLC**  
2066 W 11th Street, Upland, CA 91786  
Tel: (800) 452-6788 / (909) 946-3197  
Fax: (909) 946-3597

**Ultra-Violet Products Ltd.**  
Unit 1, Trinity Hall Farm Estate  
Nuffield Road Cambridge CB4 1TG UK  
Tel: +44(0)1223-420022 / Fax: +44(0)1223-420561

Web Site: [www.uvp.com](http://www.uvp.com)

81-0247-01 Rev X

## Introduction

The HEPA/UV3 PCR Systems create an ideal environment for preparing PCR and other samples by reducing the chance of contamination with the filtered air treated by the HEPA/UV system which blows into the PCR chamber. The built-in high intensity shortwave (254nm) UV provides a source for inactivation of DNA between experiments. Additional contamination control is provided by the uniquely coated stainless steel and aluminum design that maintains antimicrobial efficacy. The surface resists growth of destructive bacteria, molds, and fungi. Makrolon® panel assembly blocks UV under 400nm.

## Safety Information

The HEPA/UV3 PCR Systems are designed with function, reliability, and safety in mind. **Caution:** The units include shortwave UV, which is a powerful source of UV radiation that will cause damage to unprotected eyes and skin. Before operating, ensure all personnel are properly protected and that instructions for use of this equipment are followed. A safety shut-off switch automatically turns the UV light off when the door is open, protecting users from UV exposure. The Makrolon® panels are specially formulated to block UV wavelengths below 400nm.

Disconnect the power supply before servicing or fully assembling the PCR system.

## Specifications

<b>HEPA/UV PCR MODELS</b>	
<b>HEPA UV3 PCR Cabinet</b>	<b>HEPA UV3 PCR Workstation</b>
95-0434-01 115V 95-0434-02 230V UK 95-0434-04 230V Euro 95-0434-03 100V	95-0438-01 115V 95-0438-02 230V UK 95-0438-04 230V Euro 95-0438-03 100V
<b>Light Sources:</b> 254nm 8-watt UV: Filter area Chamber UV/air circulator White – 8-watt: Chamber	<b>Light Sources:</b> 254nm UV: Filter area 8-watt Chamber 25-watt UV/air circulator 8-watt White – 8-watt: Chamber
<b>Three stage filters:</b> Pre-filter Carbon filter HEPA filter	<b>Three stage filters:</b> Pre-filter Carbon filter HEPA filter
<b>Features include:</b> Two power outlets Two small shelves UV Timer Antimicrobial coated stainless steel (work surface) and aluminum Makrolon® panels block below 400nm	<b>Features include:</b> Four power outlets Two shelves UV Timer Antimicrobial coated stainless steel (work surface) and aluminum Makrolon® panels block below 400nm
<b>Dimensions:</b> Exterior: 32.5H x 21.4W x 24D in. (826 x 544 x 610 mm) Interior: 19.7W x 21.4D in. (500 x 544 mm)	<b>Dimensions:</b> Exterior: 32.5H x 29W x 24D in. (826 x 737 x 610 mm) Interior: 27.8W x 21.4D in. (706 x 544 mm)

<b>HEPA/UV</b>	
Three stage filter UV Source	Pre-filter, carbon-filter and HEPA-filter One 8-watt 254nm shortwave UV tube
<b>Chamber Light Sources</b>	
<b>Workstation:</b> UV Source - Chamber UV Air Circulator White Light	Two 25-watt 254nm shortwave UV tubes One 8-watt 254nm shortwave UV tube Two 8-watt white tubes
<b>Cabinet:</b> UV Source - Chamber UV Air Circulator White Light	Four 8-watt 254nm shortwave UV tubes One 8-watt 254nm shortwave UV tube Two 8-watt white tubes
<b>Power Outlets</b>	Built-in outlets for operating instruments inside the chamber: Four in the Workstation, two in the Cabinet
<b>Shelves</b>	
Construction Dim. (for Workstation) Dim. (for Cabinet)	Two - Formed antimicrobial coated aluminum 13"W x 4.2"D (330 x 107mm) 8.75" x 4"D (222 x 102mm)
<b>Construction</b>	
Interior Exterior Door and Side Panels	Antimicrobial coated stainless steel (horizontal work surface) and aluminum Aluminum powder coated Two panel Makrolon® assembly Blocks UV under 400nm
<b>Electrical</b>	
115V - 60 Hz, 230V - 50 Hz, 100V - 50/60Hz	

## Operational Ratings

- Unit intended to be used indoors
- Altitude must not exceed 2000 m
- Ambient temperature not to exceed 5°C to 40°C (41°F to 104°F)
- Relative humidity not to exceed 80% for temperatures up to 31°C (88°F) decreasing linearly to 50% relative humidity at 40°C (104°F)
- Mains supply voltage fluctuations up to  $\pm 10\%$  of the nominal voltage
- Pollution rating 2 or better for laboratory areas

Part Number	Voltage	Max Amps
95-0434-01	115V	9.1
95-0434-02	230V	8.7
95-0434-04	230V	8.7
95-0434-03	100V	9.1
95-0434-05	230V	8.7
95-0438-01	115V	9.1
95-0438-02	230V	8.7
95-0438-04	230V	8.7
95-0438-03	100V	9.1
95-0438-05	230V	8.7

## Assembling the PCR System

Carefully remove the unit from the packaging materials. Follow the assembly instructions provided in this manual. **NOTE:** Place the PCR base on a level surface large enough to accommodate the entire base. The surface must be level to ensure proper alignment of the Makrolon® panels.

### Tools Required

- Philips head screwdriver
- Flathead screwdriver
- Gloves, to reduce transfer of fingerprints to PCR components

Two people are recommended for assembly or lifting of this equipment.

**NOTE:** Assembly drawings show the 95-0436-01 UV2 PCR Cabinet. These instructions apply for all PCR models.

### Outer Back Panel

**NOTE:** The outer and inner back panels and shelf bracket are assembled at the factory for shipping purposes. The metal Makrolon® frames (2) are taped to the panels. Disassemble the back panels/shelf bracket and remove the protective film prior to completing the assembly instructions below.

1. Attach the outer back panel to the base with two screws as shown below.

**Do not tighten the screws at this time.**

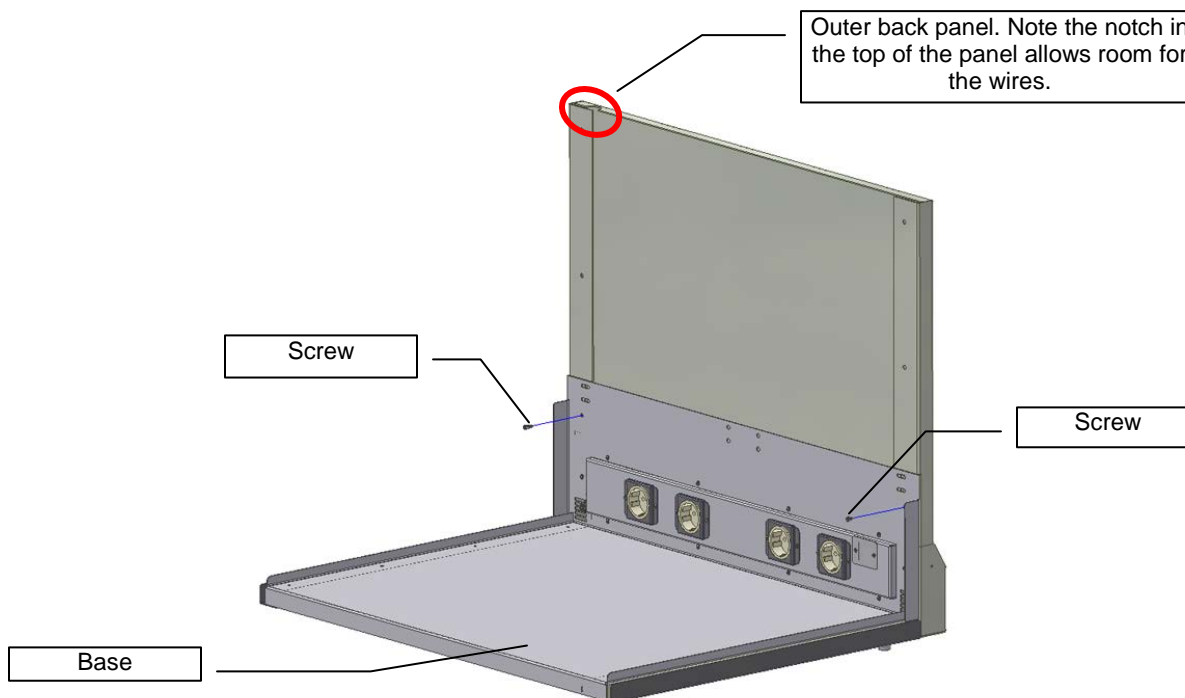

## Inner Back Panel

1. Position the wires so that they run between the inner back panel and the outer back panel up to the top for later connection to the top assembly.
2. Position the inner back panel so that the screw holes are aligned with the outer back panel. Attach the inner back panel to the outer back panel with four (4) screws. Make sure the wires come out of the cutout in the back panel, as shown by the red circle below.
3. Secure the shelf bracket in front of the inner back panel using:
  - a. Eight (8) screws in the Workstation or
  - b. Six (6) screws in the Cabinet

**NOTE: Two people are required to hold the panels in place and insert the screws.**

**Do not fully tighten screws at this time.**

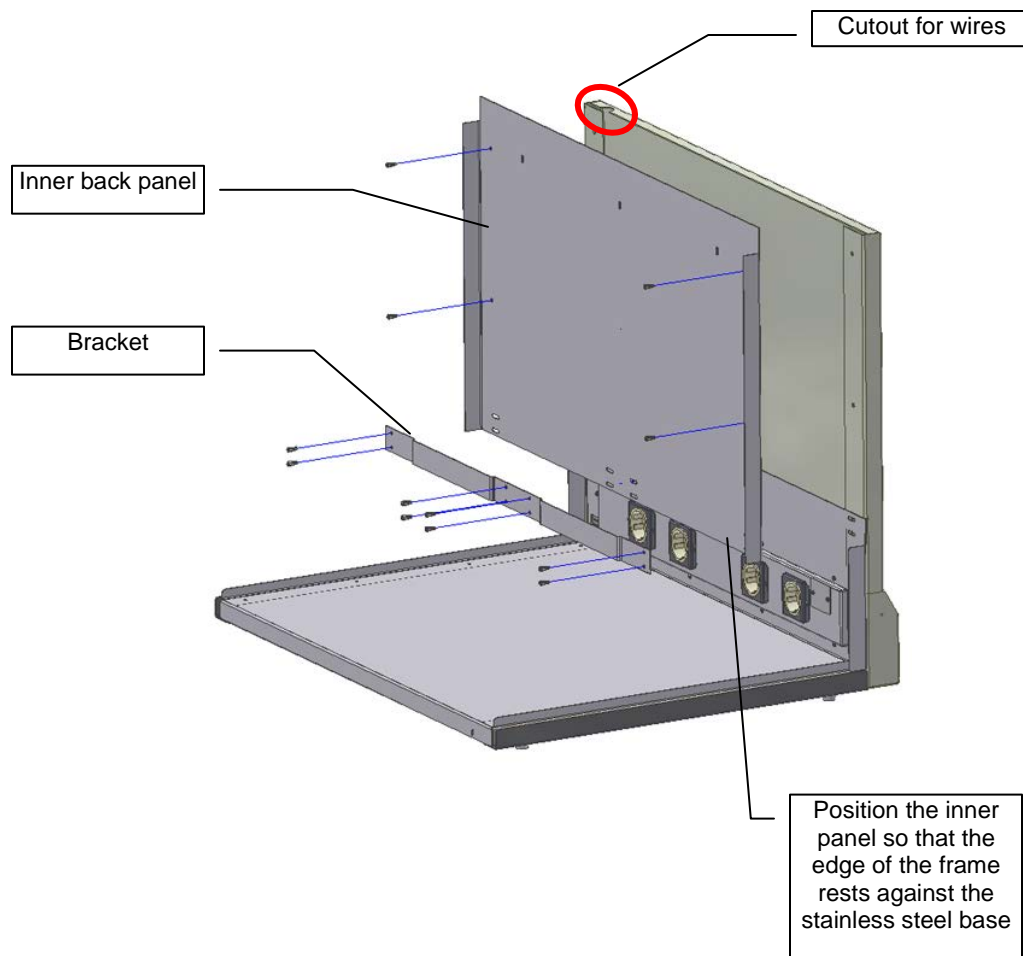

## Makrolon® Panel Assembly

1. Loosen the screws (4 per side) attaching the Makrolon® panel frames to the inner back panel.
2. Slide the frames for the Makrolon® panels under the screws on the inner back assembly so that the frames are under the shelf brackets.
3. Remove the protective film from the Makrolon® panels. Slide the panels into position between the brackets and the inner back panel.
4. Press the brackets tightly against the Makrolon® panels.
5. Tighten all frame screws to secure the Makrolon® panels in place.

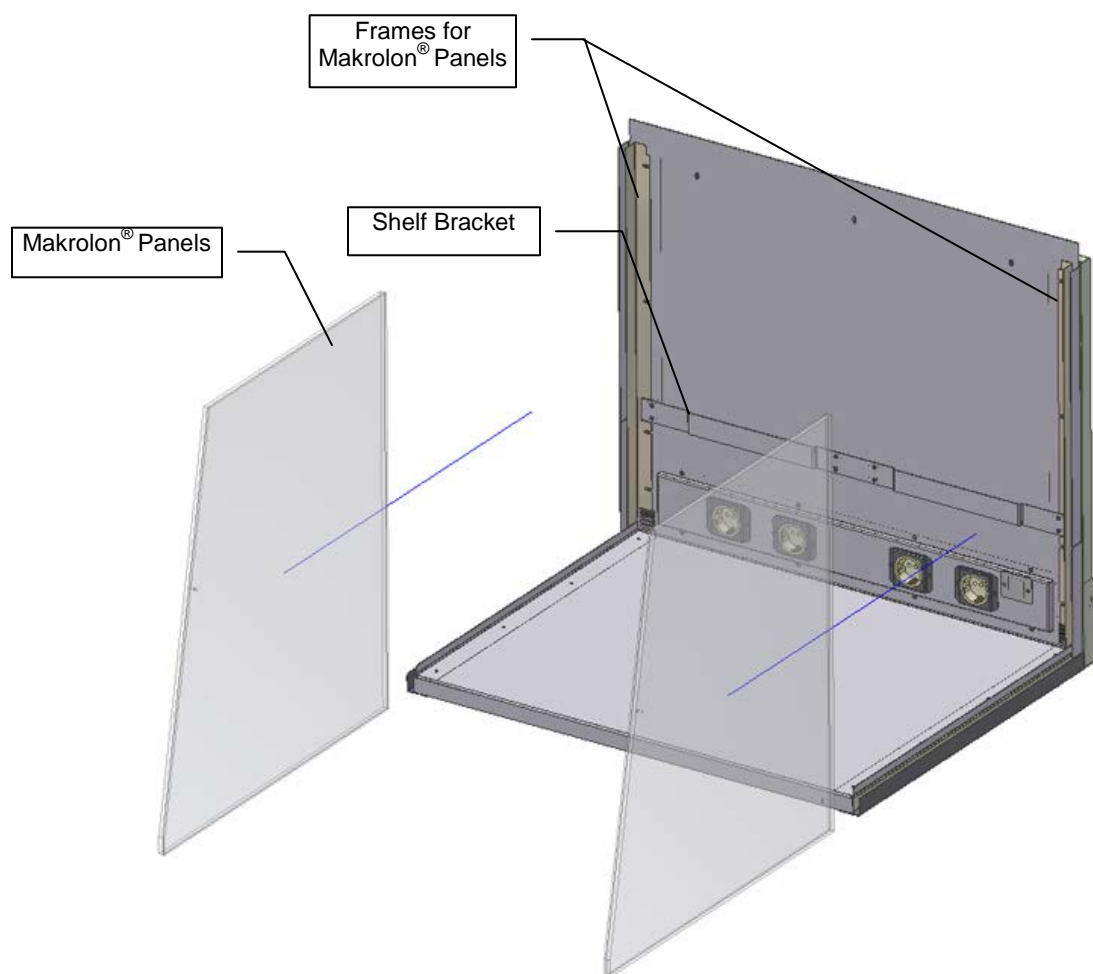

## Top Assembly and Shelf Assembly

1. Rest the top assembly on top of the unit.

**WARNING: Ensure that the unit is not plugged in.**

2. Connect the bottom and top assembly wires together according to their labels, matching wire "A" with wire "A," wire "B" with wire "B" and so forth, until all labeled wires are connected. Connect the wires by joining the male and female red connectors located on the ends of each wire. Then, connect the two unlabeled green/yellow ground wires together using the red connectors.

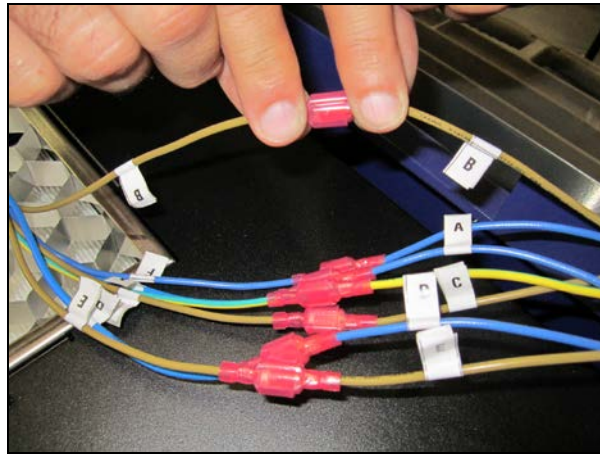

3. Slide the top assembly down so that the Makrolon® panels are inside the top assembly channels. Make sure that the back flange of the top assembly is positioned between the inner back and the outer back panel. Slide the wires into the space between the inner and outer back panels. Secure and tighten the top assembly to the back panel with screws, pushing from the back to ensure the screws are secure.
4. Slide the shelves into the shelf bracket.

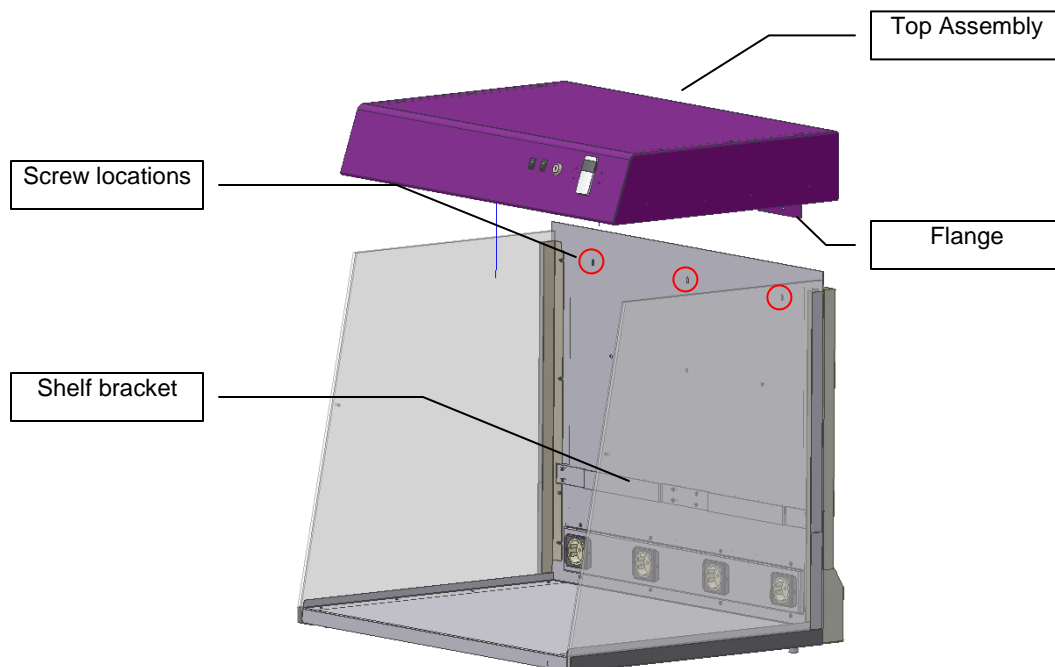

## Door Assembly

1. Slide the upper panel of the door assembly into slotted area in the top assembly. Holding the door in position, insert the thumb screws (Qty. 3) inside the top assembly.
2. Secure the upper panel of the door assembly to the left and right side panels with the two side brackets.
3. Create the door assembly by connecting the upper and lower door panels using the two hinges and 8 nuts.
4. A magnet is attached to the bottom right bracket on the door. The purpose of the magnet is to shut off the overhead UV light when the door is open.

**Note:** Some systems may have a single large bracket running along the width of the entire lower door, rather than the two small brackets shown below.

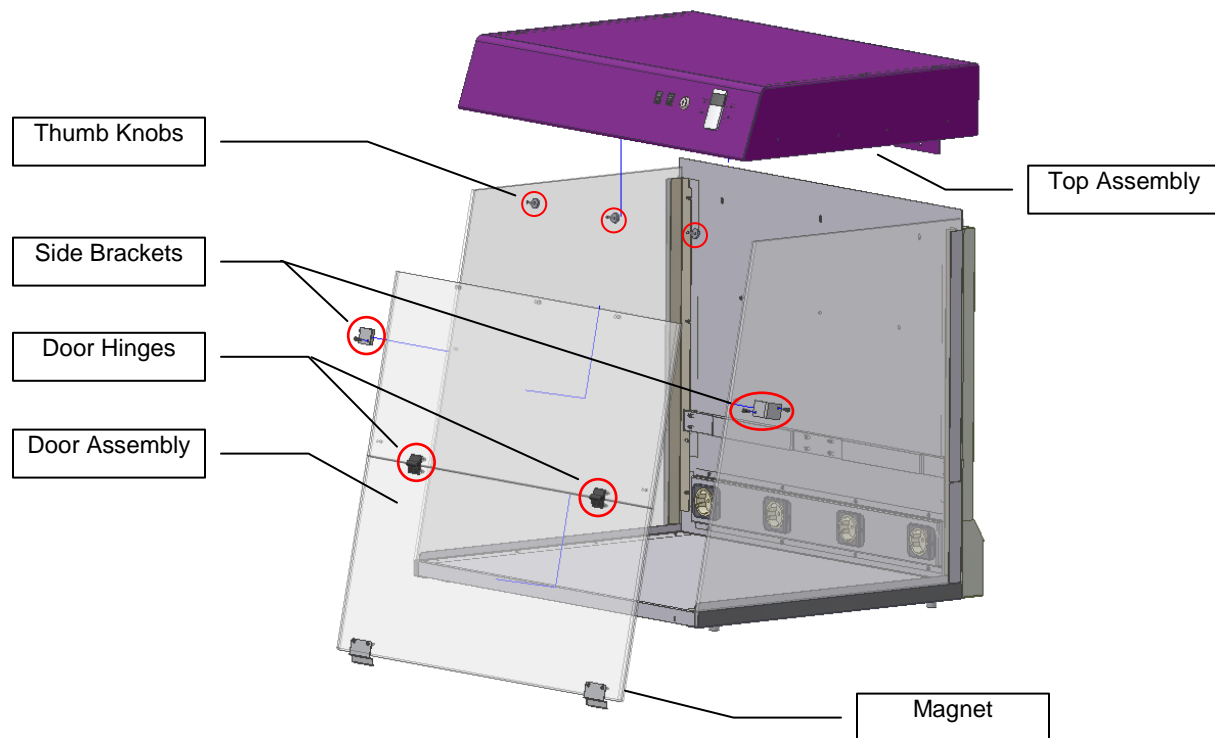

**WARNING: The PCR is for laboratory use and cannot be connected to a public power supply.**

When the PCR is assembled, plug the power cord into the back of the unit and then into a wall outlet in the laboratory.



## Operating the PCR system

The HEPA/UV3 PCR Systems feature:

- Three-stage HEPA filter system with pre filter, carbon filter and HEPA filter
- Overhead UV for decontamination of the chamber or PCR equipment
- UV safety switch and keylock for preventing exposure to UV
- Antimicrobial coated stainless steel and aluminum for reducing bacterial growth
- Easy-access door
- Overhead white light
- Shelves for placement of tools
- Plug outlets built into the chamber interior
- Built-in UV/Air Circulator; an optional module is available for the Workstation

### Use of PCR Equipment in the Chamber

Shelves are provided for placement of small tools for decontamination. The shelves slide into the bracket on back of the unit.

Power plugs built into the chamber allow use of shakers, rockers, and other equipment for PCR experiments. Equipment can be decontaminated between uses. To operate equipment within the chamber, plug the equipment into the power plug. Specific power plugs are installed as shown in the illustrations below.

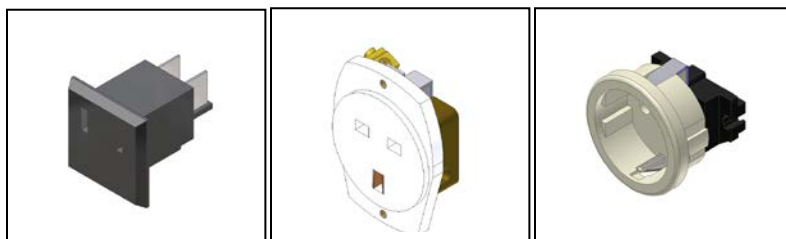

115V

230V UK

230V Euro

**NOTE: When operating equipment plugged into the outlets, combined Amps total is not to exceed 8 Amps.**

### Operating the HEPA/UV System

Push the HEPA/UV power switch to operate the HEPA/UV filter system. The airflow fan setting can be adjusted from Low to High, circulating anywhere from 22 to 50 feet per minute (FPM) of air. The filter system consists of:

- Pre-filter to preserve the life of other filters by capturing large dust particles
- Carbon filter to remove ozone, gases, odor
- HEPA filter provides a barrier (99.99%) against dust, bacteria and mold down to 0.3 micron particles (**NOTE:** The HEPA filter does not prevent particulates from entering the workstation when the Makrolon<sup>®</sup> door is open).

## Operating the UV/Air Circulator

The UV/Air Circulator is built into the PCR systems. To operate the circulator, press the UV/Air Circulator switch to the ON position. The circulator will pull air from inside the chamber through the circulator, decontaminating the air with shortwave UV and blowing the air back into the chamber.

NOTE: Do not place equipment in front of the air vents to block air flow.

*Decontaminated UV airflow into and out of the chamber*



## Operating the Overhead UV and Fluorescent White Light

### UV Keylock

The HEPA/UV3 PCR System provides an automated process for eliminating contamination by utilizing the germicidal properties of shortwave 254nm ultraviolet light. The UV light is typically operated when no samples are inside the chamber. The chamber is decontaminated, eliminating viable fungi, bacteria, and yeast.

An optional UV/Air Circulator module can be mounted into the workstation chamber for elimination of amplicons of DNA or genomic DNA from a previously dispensed experiment. Power switch, outlet, and mounting brackets are pre-installed at the factory if users purchase a module at a later time.

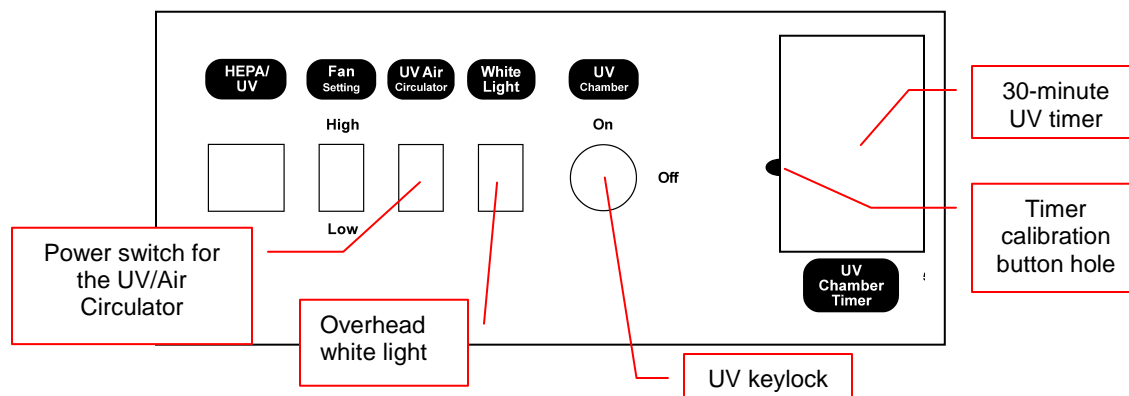

To use the UV decontamination function, turn the **UV keylock ON**, and then press the **timer** to operate the germicidal lamp housed within the chamber. The UV timer allows selection of UV exposure time. The timer may take a few seconds to initialize once the timer has power. The timer will only operate when the door is shut and the magnetic safety switch on the door is engaged. When door is open the timer will not operate.

The default timer setting is 30 minutes, adjustable at 5 minute increments from 5 to 60 minutes, then at 15 minute increments up to 12 hours. To adjust the timer settings:

1. Turn the system on and wait until the timer reads "OFF".
2. Use a small paper clip to press the **Timer calibration button** located in the small hole to the left of the timer for one second.
3. Press the main timer button to adjust the timer settings. Each press will increase the amount of time by 5 minutes (eg 35:00, 40:00, etc.) until one hour is reached. After one hour is reached, the time will be adjusted in 15-minute increments and will read without a colon. For example, one hour will read "1 00," one hour and 15 minutes will read "1 15" and so forth.

4. Once the desired time setting is reached, do not press any additional buttons. The timer will then cycle through the remainder of its settings. When the timer reads "OFF" for 5 seconds without blinking, the timer is ready to use with the new time setting.

Turn the key to the off position after UV irradiation to prevent exposure of samples to the UV. Ensure the key is completely inserted into the lock.

**[Note]** A safety switch sensor is built into the bottom of the door. When the door is opened, the ultraviolet lights will automatically shut off.

**[Note]** Do not attempt to perform PCR procedures with the germicidal lamp on. The germicidal lamp is used to decontaminate the internal chamber of the between experiments.

**[Warning]** Exposure to UV light is harmful.

The Makrolon<sup>®</sup> door is UV blocking and will not allow UV radiation to pass through the door. The germicidal tubes will shut off if the panel door is opened. The PCR Workstation contains a powerful source of UV radiation that will cause damage to unprotected eyes and skin. Before operating any unit, be sure all personnel in the area are properly protected. Even though the unit shuts the UV off when the door is open, UV Blocking Eyewear should be worn as well. UVP has a complete line of UV Blocking Eyewear: Spectacles, Goggles and Faceshield designed for this purpose.

Extended periods of time UV exposure can be used to disinfect the interior chamber by the destruction of organisms. Refer to the Maintenance section for information on measuring the intensity of the UV tubes with a UV meter.

### Overhead White Light

The overhead white lights can remain lit at any time throughout experiment procedures or the decontamination process. The fluorescent white light provides a bright light within the PCR Workstation. To use the white light, press the ON button located on the top panel.

## Care and Cleaning

The units are built to provide trouble-free operation.

**NOTE:** The door and side panels are made of Makrolon<sup>®</sup> and are subject to scuffing and scratches if improperly cleaned. If crazing of the Makrolon<sup>®</sup> panel occurs, the panel can be replaced. Refer to Replacement Parts for part numbers.

The stainless steel and aluminum surfaces are manufactured with an antimicrobial coating to reduce bacterial growth. Care in cleaning and use of the equipment is recommended to reduce wear of the coating. To clean the unit:

- Wipe excess water from inside the unit and outside the unit with an absorbent soft cloth or sponge.
- Use mild soap and a damp soft cloth or damp sponge to clean the exterior of the unit.
- Use a mild detergent on the interior surfaces.
- **Warning:** Unplug the unit before cleaning around the UV tube contacts and internal plug outlets.
- Clean the door with a mild detergent; **never** use organic based compounds, Alcohol, or Ammonia containing cleaners.
- Do not use abrasive pads or cleansers.
- A plastic cleaner solution is recommended to clean the door and is available from local plastic supply distributors.

## Maintenance, Replacement Parts/Accessories and Technical Assistance

### Replacement Parts and Accessories

Replacement parts are listed below. Only authorized UVP service personnel should perform repairs or replacements other than specified in these procedures.

Replacement Parts	Part Number
Pre-filter	38-0314-01
Carbon-filter	76-0352-01
HEPA filter	17-0113-01
Shelf, small 8.8"W (for cabinets)	20-1209-01
Shelf, large 13"W (for workstations)	20-0970-02
Fuse (2 required)	56-0049-01
<b>Makrolon® Panels</b>	
Side Panels (2 Required)	10-0618-01
Upper Door Panel (Workstation)	10-0619-01
Lower Door Panel (Workstation)	10-0620-01
Upper Door Panel (Cabinet)	10-0621-01
Lower Door Panel (Cabinet)	10-0622-01

### Replacement Tubes

System/Part Number	Replacement Tube	Tube Description	Qty.
UV3 HEPA PCR Cabinet	34-0007-01	8 Watt 254nm UV	6
95-0434-xx	34-0056-01	8 Watt White	2
UV3 HEPA PCR Workstation	34-0007-01	8 Watt 254nm UV	2
95-0438-XX	34-0056-01	8 Watt White	2
	34-0073-01	25 Watt 254nm UV	2

Accessories	Part Number
Table, stainless steel top	98-0077-01
UVX Radiometer	97-0015-02
UVX Sensor (UVX-25)	97-0016-01
J-225 Meter	97-0004-01
Spectacles, UV blocking (UVC-303)	98-0002-01
Goggles, UV blocking (UVC-503)	98-0002-02
Face Shield, UV blocking (UVC-803)	98-0002-04



### Replacing the Filters

Recommended filter replacement schedule to maintain optimum filter performance:

<b>HEPA filter:</b>	Every 6 months or when significant drop in airflow is observed
<b>Carbon filter:</b>	Once a year
<b>Pre-filter:</b>	Once a year

1. To replace any of the filters or the UV tube in the HEPA/UV system, unscrew knobs (2) located on the ceiling of the workstation to release compression in the HEPA/UV system.
2. Open the HEPA/UV door located on the left of the workstation to access the filters.
3. **Pre-filter.** The Pre-filter (38-0314-01) is located on the inside of the HEPA/UV door. To remove, open the door and slide the filter off of the door.
4. **Carbon Filter.** Slide the filter assembly out of the chamber. The Carbon Filter (76-0352-01) then slides to the right out of the filter assembly. If the filter does not slide out easily, loosen the thumb screws in front of the filter.

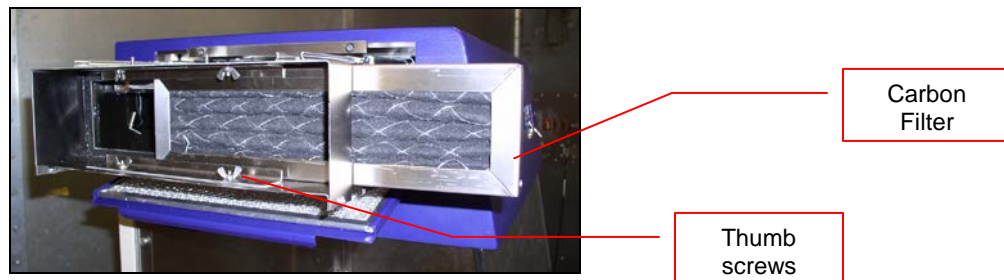
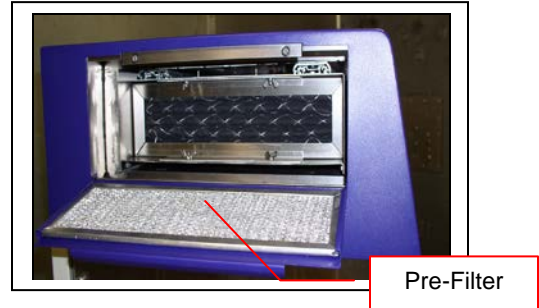

5. **HEPA Filter.** To replace the HEPA filter, slide the filter assembly out of the chamber and remove the carbon filter if not already removed. Turn the knobs counterclockwise to loosen. Open the HEPA door.

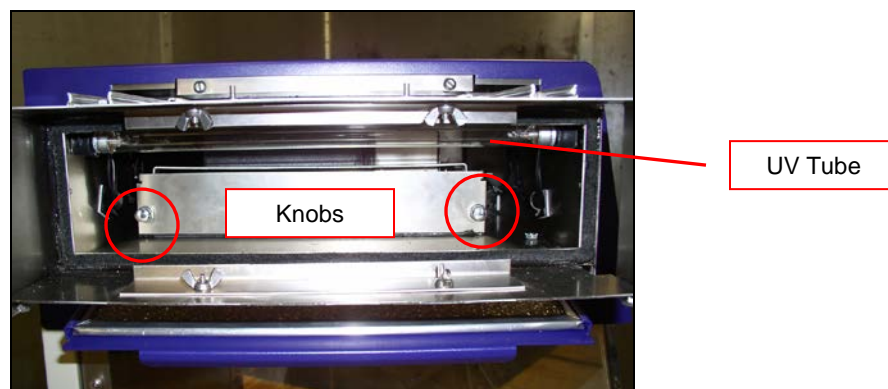

Slide the HEPA filter out and replace filter. Close door and tighten the knobs (turn clockwise). Insert the carbon filter. Tighten the carbon filter thumbscrews if loose. Close filter door. Retighten the knobs (2) on the workstation ceiling.

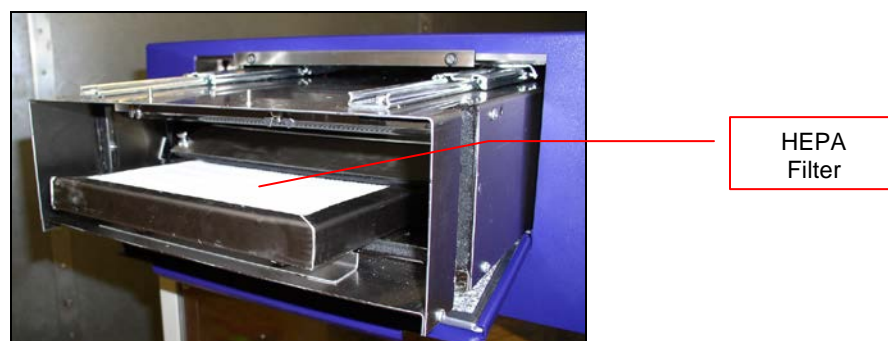

## Replacing UV Tube in the Filter System

Follow steps 1 and 2 under “Replacing the Filters” and remove the carbon filter as described in step 4 above. Step 5 shows location of the UV tube.

The tube has two prongs on each end that first fit into a socket then rotates into place. To replace the tube, carefully hold the tube on the end and insert the tube into the socket. Twist the tube 90° until the tube locks into place.

Replace carbon filter and retighten the knobs (2) on the workstation ceiling.

## Replacing the Fuses

Fuses are located on lower corner of the system. To remove the fuse, use a flathead screwdriver to turn the fuse counter-clockwise. Pull the fuse out.

Insert the new fuse and using the screwdriver, turn the fuse clockwise to lock.



## Replacing the Tube in UV/Air Circulator

1. Locate and remove the two thumb knobs on the circulator cap on the outer back panel of the system.
2. Pull the circulator cap away from the system.
3. The tube, attached to the cap, has two prongs on each end that fit into a socket. Carefully hold the tube on the ends, rotate the tube and remove from the cap. Insert a new tube into the socket. Twist the tube 90° until the tube locks into place.

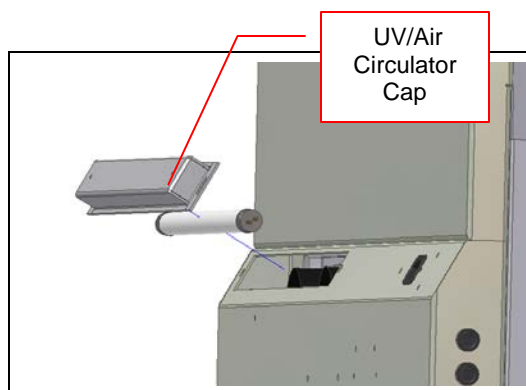

4. Replace the place cap back into position and reattach the two thumb knobs.

## Replacing Tubes in the Chamber

Turn the unit power off and unplug the unit from the outlet. Lift up the panel door and locate the tubes. The tube has two prongs on each end that first fit into a socket then rotates into place. Carefully hold the tube on the end and insert the tube into the socket. Twist the tube 90° until the tube locks into place.

Note that UV tubes are clear while white light tubes are white.

## Measuring the UV Tube Intensity

As the ultraviolet tubes age, the intensity and germicidal destruction rate decreases. It is important to monitor the efficiency of the tubes to ensure the germicidal requirements are met. The germicidal destruction rate is a function of the UV intensity at wavelength 254nm and exposure time. The lower the tube intensity, the longer the lamps must be on to accomplish the same objective.

The UVX Radiometer using a 254nm sensor will allow the user to measure the 254nm emissions from the tubes. When it is time to measure the UV intensity inside the PCR workstation (recommended weekly or when needed), the sensors can be placed on the floor of the PCR. Close the hood and turn on the UV tubes. Wait 3 minutes to record the measurement on the UV meter. It is recommended that the user record an initial value upon receipt and assembly of the PCR unit.

The germicidal destruction rate calculation:

$$\text{Microwatt seconds/cm}^2 = \text{microwatts/cm}^2 \times \text{seconds of exposure}$$

For ordering information on the UVX Radiometer, J-225 meter and sensors, refer to the **Replacement Parts and Accessories** section in this manual.

**Bacterial Destruction Chart.** The bacterial destruction chart below indicates the amount of shortwave (254nm) UV energy required for complete destruction of various organisms.

Bacterial Organisms	Microwatt seconds/cm <sup>2</sup>	Additional Organisms	Microwatt seconds/cm <sup>2</sup>
Bacillus anthracis	8700	<b>YEAST</b>	
S. enteritidis	7600	Saccharomyces ellipsoideus	13200
B. Megatherium sp. (veg.)	2500	Saccharomyces sp.	17600
B. Megatherium sp. (spores)	5200	Saccharomyces cerevisiae	13200
B. paratyphosus	6100	Brewer's yeast	6600
B. subtilis	11000	Baker's yeast	8800
B. subtilis spores	22000	Common yeast cake	13200
Clostridium tetani	22000		
Corynebacterium diptheriae	6500	<b>MOLD SPORES</b>	
Eberthella typosa	4100	Penicillium roqueforti	26400
Escherichia coli	6600	Penicillium expansum	22000
Micrococcus cadidus	12300	Penicillium digitatus	88000
Micrococcus sphaeroides	15400	Aspergillus glaucus	88000
Mycobacterium tuberculosis	1000	Aspergillus flavus	99000
Neisseria catarrhalis	8500	Aspergillus niger	330000
Phytomonas tumefaciens	8500	Rhisopus nigricans	220000
Proteus vulgaris	6600	Mucor racemosus A	35200
Pseudomonas aeruginosa	10500	Mucor racemosus B	35200
Pseudomonas fluorescens	6600	Oospora lactis	11000
S. typhimuseum	15200		
Salmonella	10000	<b>VIRUS</b>	
Sarcina lutea	26400	Bacteriophage (E. coli)	6600
Sarratia marcescens	6160	Tobacco mosaic	44000
Dysentery bacilli	4200	Influenza	6600
Shigella paradyseneriae	3200		
Spirillum rubrum	6160	<b>PROTOZOA</b>	
Staphylococcus albus	5720	Paramecium	200000
Staphylococcus aureus	6600	Nematode eggs	9200
Streptococcus hemolyticus	5500	Chlorella vulgaris (algae)	22000
Streptococcus lactis	8800		
Streptococcus viridans	3800		

## Technical Assistance

Note: **A Returned Goods Authorization (RGA) number** must be obtained from UVP Customer Service before returning any product.

UVP offers technical support for all of its products. If you have any questions about the product's use, operation or repair, please contact our offices at the locations below. Contact UVP's Customer Service based on your location:

<b>N. America, S. America, Asia, Australia:</b>	<b>Europe, Africa, Middle East:</b>
<b>Call (800) 452-6788 or (909) 946-3197 Customer Service 7:00 am and 5:00 pm PST</b>	<b>Call +44(0) 1223-420022 Customer Service 8:30 a.m. and 5:30 p.m.</b>
<b>E-Mail to: <a href="mailto:info@uvp.com">info@uvp.com</a></b>	<b>E-Mail to: <a href="mailto:uvp@uvp.co.uk">uvp@uvp.co.uk</a></b>
<b>Fax Customer Service at: (909) 946-3597</b>	<b>Fax Customer Service at: +44(0)1223-420561</b>
<b>Write to:</b> UVP, LLC 2066 W. 11 <sup>th</sup> Street, Upland, CA 91786 USA	<b>Write to:</b> Ultra-Violet Products Ltd., Unit 1, Trinity Hall, Nuffield Road, Cambridge CB4 1TG UK

## Warranty

UVP, LLC warrants its products to be free of defects in materials and workmanship for a period of two (2) years from the date of purchase. The foregoing warranty of UVP shall be of no force and effect if buyer has modified or damaged the product. Tubes and filters are warranted for 90 days.

**NOTE:** "Crazing" (cracking and/or yellowing) of the Makrolon<sup>®</sup> panels may occur within the warranty period. This is regarded as normal wear and tear and is not covered by the warranty.

All warranties or merchantability and fitness for any purpose and all other warranties, expressed or implied, except those expressly set forth herein, are deemed waived and excluded.

UVP's duty under the warranty is limited to replacement and/or repair of the defective part at the option of UVP, LLC. UVP shall not be liable for any expenses or damages incurred by the purchaser except as expressly set forth herein, and in no event shall UVP be liable for any special, incidental or consequential damages of any kind. This warranty does not supersede any statutory rights that may be available in certain countries.