

Model 410 Classic Flame Photometer

Operator Manual

Copyright 2010 Sherwood Scientific Ltd.
All rights reserved.

Intended Use

This operator's manual contains complete instructions for setting up and using the Model 410. Service information for use by appropriately qualified personnel is also available.

The Model 410 is intended for use by persons knowledgeable in safe laboratory practices. If the instrument is not used in accordance with these instructions for use, the protection provided by the equipment may be impaired.

WARNING *The Model 410 is designed to be grounded through the power supply lead (line cord) for safe operation. For the safety of operating personnel and optimum performance make sure that the instrument is only connected to a 3-prong socket (outlet) that has an effective earth connection. If you are in any doubt about the safety of your electrical supply system consult a competent, qualified electrician.*

There are no user replaceable parts within the instrument. Do not remove the rear cover from the instrument.

Sherwood Scientific Limited and its authorized Distributors and Agents consider themselves responsible for the effects of safety, reliability and performance of the Model 410 only if: -

- Assembly operations, extensions, re-adjustments, modifications or repairs are only carried out by persons authorized by them.
- The electrical installation of the relevant room complies with IEC requirements or the local regulatory code.
- The equipment is used in accordance with the instructions for use.

The information contained in this manual was correct at the time of going to print. However, Sherwood Scientific's policy is one of continuous product improvement and the right to change specifications, equipment and maintenance procedures at any time, without notice, are reserved. This manual is copyrighted, and all rights are reserved. No part of this manual may be reproduced by any means or in any form without prior consent in writing.

Sherwood Scientific Ltd,
1 The Paddocks,
Cherry Hinton Road,
Cambridge,
CB1 8DH,
United Kingdom

Tel +44 1223 243444

Fax +44 1223 243300

Email info@sherwood-scientific.com

www.sherwood-scientific.com

Contents

	Page
Intended Use	2
1 Introduction	5
1.1 Introduction	5
1.2 Summary of the Test	5
1.3 Flame Photometry Principles of Operation	6
1.4 Reagents	6
Dilutions	6
Storage	6
Purification	6
2 Installation	7
2.1 Services Required	7
Electrical Supply	7
Fuel	7
Air	7
Waste Container	7
2.2 Site Conditions	8
2.3 Unpacking	8
Accessory List	8
2.4 Assembly	9
2.5 Connecting a Chart Recorder	12
3 Performance Characteristics and Specification	13
3.1 Readout	13
3.2 Measurement Ranges	13
3.3 Specificity	13
3.4 Accuracy	13
Linearity	13
Drift	13
Reproducibility	13
3.5 Warm Up	14
3.6 Sample Requirement	14
Type	14
Method of presentation	14
Volume	14
3.7 Chart Recorder Output	14
3.8 Environmental Conditions	14
Temperature	14
Humidity	14
Installation Category	14
3.9 Power Requirements	14
Voltage	14
Fuses	14
Power	14
3.10 Size	14
3.11 Weight	14

Contents

	Page
4 Operating Instructions	15
4.1 Front Panel Controls and Indicators	15
Power on	15
Flame on	15
Blank	15
Sensitivity Fine and Coarse	15
Fuel	15
Na, K, Ca	15
Decimal	15
Power 0/1	15
4.2 Rear Panel Controls and Connectors	17
Power	17
Data output	17
Gas	17
Air	17
Air regulator	17
4.3 Initial Adjustment	19
4.4 Operating Instructions	20
4.5 Shutdown Procedure	22
4.6 Operating Hints	22
5 Operational Precautions and Limitations	23
5.1 General	23
5.2 Hazards	23
6 Maintenance	24
6.1 General	24
6.2 Daily Maintenance	24
6.3 Weekly Maintenance	24
6.4 Monthly Maintenance	24
6.5 Six-Monthly Maintenance	25
6.6 Nebuliser	25
Operational Check	25
Cleaning the Nebuliser	25
6.7 Cleaning the Mixing Chamber, Burner and Drain	27
6.8 Cleaning the Optical Filters and Glass Chimney	28
6.9 Voltage Selection and Fuse Replacement	30
6.10 Deproteinising or Disinfecting Procedure	31
7 Troubleshooting	32
7.1 Power on LED not illuminated	32
7.2 Flame on LED not illuminated	32
General	32
Air Supply	32
Fuel Supply	32
7.3 Unable to set display to zero	33
7.4 Unable to set display to standard reading	33
7.5 Unstable results	33
7.6 Non-linear results	35
8 Spares and Accessories	35
8.1 Ordering Information	35
8.2 Spares and Accessories	35
8.3 Standard Solutions	36
Appendix A Bibliography	37
Appendix B Installing a Natural Gas Regulator Kit	38
Product Warranty	40

Introduction

1.1 Introduction

The Model 410 Classic is a single channel, low temperature flame photometer. It is supplied as standard, for the determination of Sodium (Na), Potassium (K) and Calcium (Ca).

A Digital Interface Module is available to enable connection to a printer or PC with the option to linearise Na results between 0.5ppm and 20ppm.

Application software is available which enables calibration with curve fitting, automatic drift correction and the ability to control a Model 860 Autosampler.

An automatic sample dilutor, Model 805 is also available.

Additional filters are available to allow the determination of Barium (Ba), Cesium (Cs), Rubidium (Rb) and Strontium (Sr). Information regarding Ba, Cs, Rb and Sr determinations is available from your Sherwood Scientific distributor.

Please refer to Section 8.2 for a complete list of accessories.

The Model 410 has a fail-safe device, which automatically stops the gas flow if the flame does not ignite, or if during operation, the flame is extinguished. Plus an air pressure switch so that if the air pressure falls below a specified value the flame will not ignite or will be extinguished.

1.2 Summary of the Test

NOTE References are listed in Appendix A.

In many applications, rapid availability of results is of prime importance. By flame photometry both Sodium and Potassium results on a single sample can be available in less than 5 minutes of the sample reaching the laboratory. (The same is true of Lithium results, a determination that was never carried out before the advent of flame photometry). A simple dilution step is all that is required; therefore sample handling, losses and inaccuracies are at a minimum (Ref. 3-10)

Prior to the advent of flame photometry, Sodium and Potassium were typically determined gravimetrically after the precipitation of relatively insoluble salts such as Sodium Uranyl Zinc Acetate (Ref. 1) and Potassium Chloroplatinate (Ref. 2). As with all chemical methods for these two elements there were cross interferences and also interference from other ions such as NH_4^+ . Many analytical steps such as protein precipitation or ashing of the sample were involved with all the attendant losses and inaccuracies and the complete procedures required many hours.

Introduction continued**1.3 Flame Photometry Principles of Operation**

When a solution is aspirated into a low temperature flame, in an aerosol, each droplet of water evaporates leaving a solid core of the residue of evaporation. The core further breaks down to the molecular level, and provided the molecules are not too refractory, progress to form atomic species. The atom then is excited by the flame and its electron temporarily moves to a higher energy state.

When the electrons return to the ground state, they lose the excitation energy and a discrete wavelength of visible light is emitted, characteristic of the atom. The emitted light can be isolated from other light wavelengths by an optical filter. The amount of light being emitted is proportional to the number of atoms in the flame, and it follows, the concentration of that atom in the original solution. The amount of light emitted can be measured by a suitable photodetector.

The photodetector generates an electrical signal which is amplified and displayed on a digital readout.

1.4 Reagents

Sherwood Scientific supplies a wide range of reagents, including standards, diluent and maintenance solutions, for use with the Model 410 Flame Photometer.

Please refer to Section 9.3 for a complete list of the reagents.

Dilutions

Samples and standards must be diluted with the same batch of diluent, made up of 1 part Diluent Concentrate to 999 parts deionised or good quality distilled water.

The same batch of diluent should be used to zero the instrument and to prepare dilutions of standards and samples. This will prevent variations in water purity affecting the measurements.

Great care should be taken so that contamination does not occur when preparing the samples and standards. Remember that the accuracy of the instrument is dependent on the accuracy and purity of the standards used for calibration.

Storage

All solutions should be stored away from direct sunlight, in a cool place (below +25°C/+77°F), in an airtight container to prevent evaporation and discolouration. Glass containers should not be used, as they can affect Na concentration levels. Prolonged exposure to the atmosphere must be avoided to prevent evaporation of standard solutions, which could affect concentration.

Purification

No purification is required for Sherwood Scientific standard solutions.

2

Installation

2.1 Services Required

Electrical Supply

An a.c. supply at 100V, 120V, 220V or 240V $\pm 10\%$, at 50 or 60Hz, is required for the Model 410. The instrument operating voltage is shown on the voltage selector on the rear panel.

CAUTION *If the voltage setting is not correct for the local supply, do not attempt to use the instrument until it is correctly adjusted as detailed in Section 2.4, paragraph 11.*

Fuel

The Model 410 can work with Butane, Propane, LPG and Natural Gas. However, for Calcium determination we would only recommend the use of Propane. The use of Natural Gas is not advised for any accurate work.

A supply of High-grade Propane, Butane or Propane/Butane mixture, free of heavy hydrocarbon deposits, regulated at the cylinder to 2.1kg/cm² (30psig), flow rate at least 0.4 litres per minute. The use of industrial quality gas is not recommended as impurities can enter the delicate gas regulators and can leave deposits of oil and dirt, which will render the instrument inoperable.

Natural gas at 3 to 10 inches water gauge, regulated to 2 inches water gauge, using the optional Natural Gas Regulator Kit, can also be used. Natural gas and camping gas regulators are available as optional accessories, refer to Section 8.2.

NOTE Natural Gas may give reproducibility results outside specification.

NB The positioning of Gas cylinders should conform to National and local regulations.

Air

A supply of clean, dry, oil-free air at minimum 1kg/cm² (14psig), flow rate 6 litres per minute. A suitable Sherwood Scientific air compressor is listed in Section 8.2.

Waste Container

A sink or waste container sited to the right of the instrument will ensure the minimum length of waste tubing. Do not use a waste container with high sides, as this will cause the drain tube to be lifted above the level of the constant head drain.

Installation continued**2.2 Site Conditions**

WARNING *Under no circumstances install the instrument beneath overhanging cupboards. There must be at least 1 metre of clear space above the chimney.*

For optimum performance, this instrument should be installed in accordance with the following conditions: -

1. The environment must be clean and free from dust.
2. The instrument must be placed on a strong, level worktop, free from vibration. The Model 410 requires approximately 500mm x 500mm of bench space, which includes an area in front for solutions and clearance at the rear for fuel and air tubing, with clear access to the mains supply switch.
3. Avoid sites that expose the instrument to direct sunlight or draughts.
4. To meet specification the ambient temperature must be within the range 10°C to 35°C and the maximum relative humidity not greater than 85%, non-condensing.
5. Make sure that the correct voltage is selected for the local a.c. supply, as shown in the following table. *Do not* attempt to connect the power supply lead until the voltage is correctly set.

VOLTAGE SELECTED	VOLTAGE RANGE
100V	90V to 110V
120V	100V to 132V
220V	198V to 229V
240V	230V to 264V

2.3 Unpacking

1. Unpack the instrument and accessories.
NOTE The Model 410 weighs 9.5kg, follow safe lifting techniques.
2. Check all items for damage.
3. Check that all the items on the Accessory List have been delivered. Contact your Sherwood Scientific distributor if you have any problems.
4. The Model 410 is shipped with the following items:

Accessory List

CAT. NO.	ITEM	QUANTITY
001 72 043	Air tubing, nylon reinforced	2 metres
001 72 114	Fuel tubing	2 metres
400 22 000	Drain tube, all flame #20411 on	1 metre
001 48 105	Fuse, 200 mA slo-blo, spares	2
471 71 900	Supply lead, a.c.	1
100 99 010	Nebuliser cleaning wire, pack of 3	1 pack
001 31 076	'O' ring, spare for mixing chamber	1
420 08 102	Nebuliser	1
400 22 003	Nebuliser inlet tube, polythene, 150mm	1
410 91 000	Operators Manual, English	1
001 08 718	'Unex' tubing clamp	4
410 92 001	CDROM, Flame Training Guide	1
001 56 620	Flame Photometer Standard, 1000ppm Na, 100ml	1 pack of 6
001 56 621	Flame Photometer Standard, 1000ppm K, 100ml	1 pack of 6
001 56 623	Flame Photometer Standard, 1000ppm Ca, 100ml	1 pack of 6

Installation continued**2.4 Assembly**

EQUIPMENT REQUIRED: -

'Poqidriv' (cross head) screwdriver 1PT;

Flat blade screwdriver.

To assemble the Model 410, proceed as follows:

1. Lift off the chimney cap from the chimney assembly and lift out the glass chimney. Remove any packing material from inside, making sure that there are no small pieces left within the chimney.
2. Replace the glass chimney *with the clear strip at the bottom* and refit the chimney cap on top of the chimney.
3. Remove the nebuliser from its box and push the nebuliser barb into the air tubing (item 3, Figure 2.1). Fit the nebuliser to the mixing chamber and position the retainer to lock it into position (item 2, Figure 2.1). Fit the nebuliser inlet tube, making sure that it is pointing downwards.

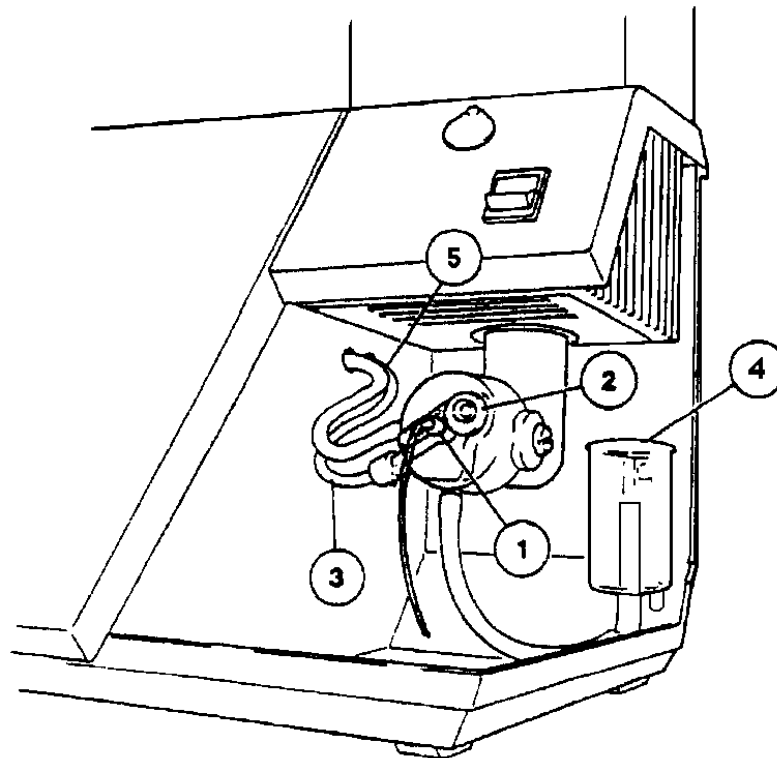

Figure 2.1 Mixing Chamber

1. Nebuliser. 2. Nebuliser retainer. 3. Air tubing. 4. Constant head & drain.
5. Fuel restrictor. 6. Fuel tubing.

4. If the instrument is to be used on Natural gas, refer to Appendix B. If Propane, LPG or Butane is to be used continue with paragraph 5.

Installation continued**2.4 Assembly** continued

5. Connect the length of rubberised fuel tubing, (001 72 114) supplied, between the inlet connector on the Propane regulator, (item 6, Figure 4.2) and the cylinder regulator outlet connector. Secure with 'Unex' tubing clamps, supplied. Ensure that the connector at the regulator inlet is tightened to 12nm torque.

NB The connection at the cylinder end of the tube must comply with National regulations.

6. Turn on the fuel supply and check all connectors for leaks, using soap solution. Do not use the instrument until you are satisfied that the installation is leakproof.
7. Connect the length of reinforced Nylon hose (001 72 043), supplied, between the air compressor outlet and the air inlet connector on the rear panel. Secure both ends with 'Unex' tubing clamps (001 08 718), supplied.
8. Fit a length of drain tubing (400 22 000) (item 4, Figure 2.4) to the outlet on the constant head drain (or Gas Trap). If necessary connect a suitable length of tubing (not supplied), to extend the drain tubing to carry waste to a sink or other drain receptacle. The downward flow of waste must not be restricted.

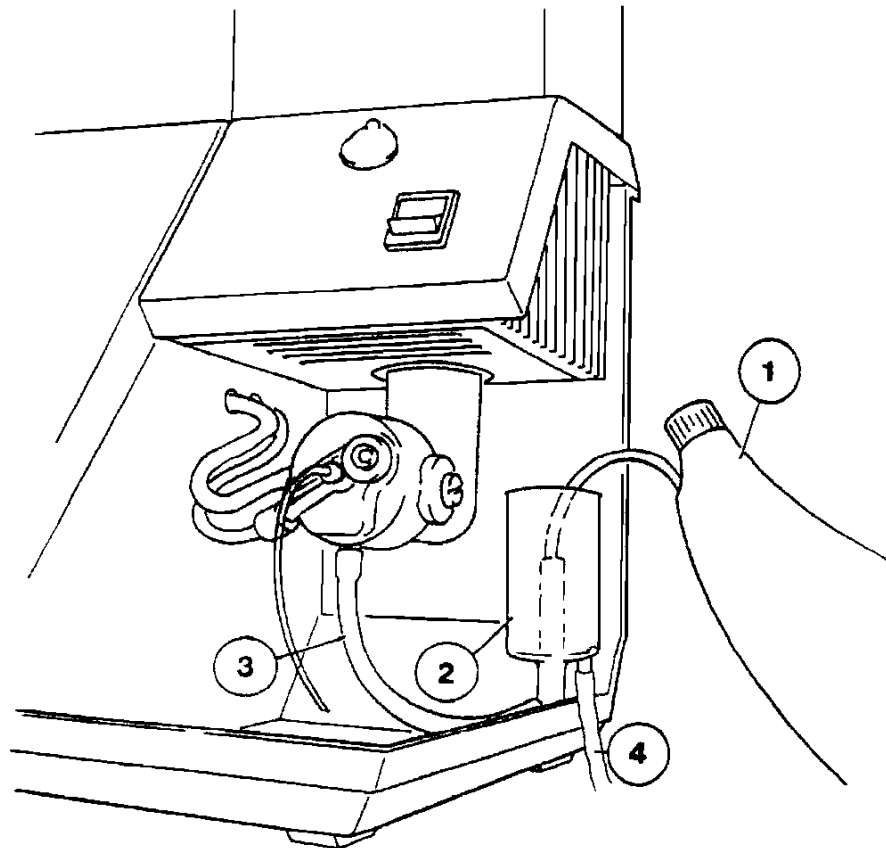

Figure 2.4 Filling the 'U' Tube

1. Wash bottle. 2. Constant head drain (Gas Trap). 3. 'U' tube. 4. Drain tube.
5. Spring clip.

Installation continued**2.4 Assembly** continued

9. *Make sure* that the constant head drain (Gas Trap) is positioned so that it is pushed fully down on its retaining screws. Use a wash bottle (item 1, Figure 2.4) to fill the 'U' tube with deionised water. Sufficient water should be used to purge the tube of air. Allow excess water to flow back into the drain.

IMPORTANT Do not continue until you are satisfied that the 'U' tube has been completely filled with water, and is purged of air.

10. The instrument is supplied with Na, K and Ca filters fitted. To replace any of these filters, refer to Section 6.8.

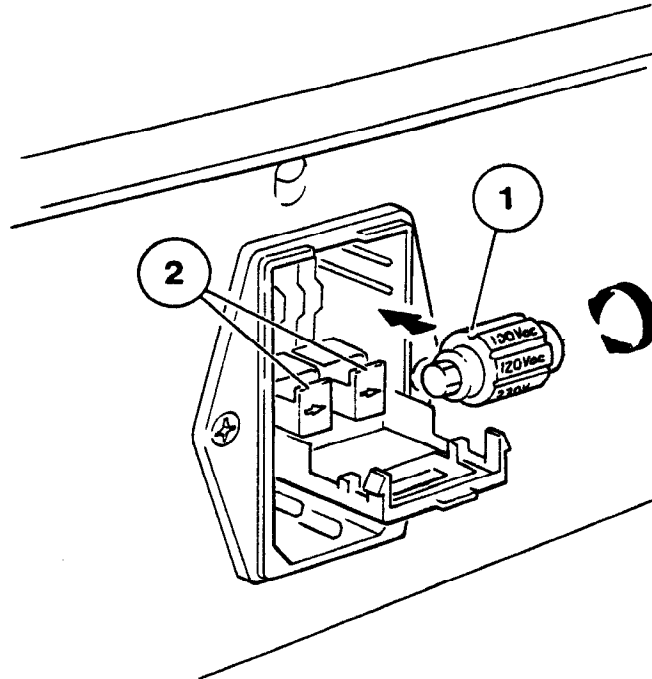

Figure 2.5 Voltage Selector

1. Voltage selector. 2. Fuse holders.

11. Check that the voltage shown on the voltage selector is correct for the local supply. If it is not, open the voltage selector compartment. Slide the voltage selector bobbin (item 1, Figure 2.5) out of the instrument and replace it so that the required voltage setting will be visible through the window of the compartment cover. Close the compartment cover.

CAUTION Do not attempt to rotate the voltage selector bobbin when it is fitted in the voltage selector, as this will damage the contacts.

Installation continued**2.4 Assembly** continued

12. Fit a suitable 3-pin plug to the a.c. supply lead. Check that the correct colour coded leads are connected to the plug terminals. Follow the plug manufacturer's fitting instructions.

CAUTION Ensure that the green/yellow earth connector in the a.c. supply lead is connected to a properly grounded earth point, the brown lead is connected to the Line terminal (L) and blue lead is connected to the Neutral terminal (N).

13. If necessary, set the *power switch* (below the chimney) to the 0 position. Connect the a.c. supply lead to the *power* receptacle on the rear panel and connect the plug to a convenient supply socket.
14. If a chart recorder is to be used with the instrument continue with Section 2.5. If not, continue with Section 5, Operating Instructions.

2.5 Connecting a Chart Recorder

1. Connect the black (-ve) recorder input lead to the black data output socket on the rear panel of the instrument.
2. Connect the red (+ve) recorder input lead to the red data output socket on the rear panel of the instrument.
3. If the chart recorder has an input-shortening link fitted, connect it between the black (negative) input and the earth input. This may reduce interference and produce a better trace.
4. Continue with Section 4, Operating Instructions.

3

Performance Characteristics and Specification

3.1 Readout

3½-digit light emitting diode (LED) display.

Display range 0 to 1999 (199.9 with decimal point on).

NOTE If negative values are displayed the instrument is operating outside of the recommended measurement range.

3.2 Measurement Ranges

Na 0.5 to 10ppm linear;
Above this range Na is non-linear due to self-absorption. A lineariser can be fitted, which will linearise concentrations up to 20ppm Na. (Part number 41086001).

K 0.5 to 100ppm

Ca 5 to 100ppm

Ba 0 to 3000ppm

These are sample concentrations directly entering the flame photometer after dilution.

3.3 Specificity

For Na and K measurements, interference will be less than 0.5% from other elements at the same concentration equal to the concentration of the element under test. Ca and Ba will normally be less than 5 % interference from other elements at the same concentration.

3.4 Accuracy

Linearity

Better than 2% of calibrated value measured at mid-range, when standardized at the following concentrations 3ppm Na, 3ppm K & 100ppm Ca.

e.g. 3ppm Na calibrated to 100 on the display will read 49 to 51 at mid-point.

NOTE A minimum 30 minutes warm up aspirating blank solution must be allowed to meet the drift specification, refer to Section 3.5.

Drift

At zero: Better than 2% per hour when calibrated at 10ppm for Na and K and at 50ppm for Ca and Ba.

At 10ppm: Better than 2% per 5 minutes, for Na, K, Ca and Ba based on 10 consecutive samples, aspirating sample for 20 seconds, then 10 seconds of blank.

Reproducibility

NOTE The following specification is correct for use on Propane or Butane. If Natural Gas is used the reproducibility will be worse.

Less than 2% CV for 20 consecutive readings of the same bulk sample, aspirating sample for 20 seconds then 10 seconds of blank. The concentration of the bulk sample to be 10ppm for Na, K and Ca which will give a standardized reading of 100 on the display, i.e. 10.0 with decimal point on.

Performance Characteristics and Specification continued

3.5 Warm Up

To achieve the stated specification the flame must be alight for a minimum of 30 minutes, *with diluent being aspirated*.

3.6 Sample Requirement**Type**

Dependent on application. However, samples should be water-based and not highly viscous nor non-homogeneous.

Organic solvents affect the air/fuel ratio, could attack the mixing chamber materials and can affect the safety operation of the Gas Trap (constant head drain) and should be used with great caution.

Method of presentation

The sample is presented to the nebuliser from a sample cup, test-tube, or other suitable container.

Volume

The maximum diluted sample volume required for 20 seconds aspiration is 2ml.

3.7 Chart Recorder Output

Nominal 100mV signal output per 1000 display units.

3.8 Environmental Conditions**Temperature**

Operating +10°C to +35°C; Transportation -40°C to +45°C.

Humidity

Operating 85% maximum at +35°C.

Transportation 95% maximum at +45°C (non condensing).

The instrument specification will be unaffected by an ambient temperature change of 4°C (or less) per hour, within the range +10°C to +35°C, with a maximum of 7°C shift during 8 hours.

Installation Category

Installation Category 1.

3.9 Power Requirements**Voltage**

90V to 132V or 198V to 264V, 50/60Hz.

Fuses

Two 200mA slo-blo fuses are fitted for all voltage ranges.

Power

20VA.

3.10 Size

Overall, including chimney and rear panel connectors, 510mm high x 390mm wide x 345mm deep.

3.11 Weight

9.5 kg, instrument only.

4

Operating Instructions

4.1 Front Panel Controls and Indicators (See Fig 4.1).

Power on

LED which illuminates when the instrument is switched on.

Flame on

LED which illuminates when the flame is alight.

Blank

This control is used to set the display to zero while aspirating a blank solution.

Sensitivity, Fine and Coarse

These two controls are used to set the display to an appropriate concentration reading, while aspirating a standard solution. The *coarse* control is a four position rotary switch and the *fine* control is a 10-turn potentiometer.

Fuel

This control provides a fine adjustment of the fuel flow and enables the optimum flame conditions to be set for each element.

Na, K, Ca

This three-position slider control selects the correct filter for the element to be determined. When used with other filter types e.g. Li or Ba, the appropriate label should be fitted in the relevant position, on the front of the chimney assembly.

Decimal

This touch control, located adjacent to the digital display, is used to select the decimal point, e.g. using the *decimal* pushbutton to select the decimal point, a reading of 1000 will be displayed as 100.0. The sensitivity of the Model 410 is unaffected by use of this control.

Power 0/1

Rocker switch that switches the a.c. power supply on (1) and off (0). When the instrument is switched on, the *power on* LED is illuminated, and an ignition cycle is initiated. When switched off, the flame is extinguished and the a.c. supply to the instrument is switched off.

Operating Instructions continued

4.1 Front Panel Controls and Indicators continued

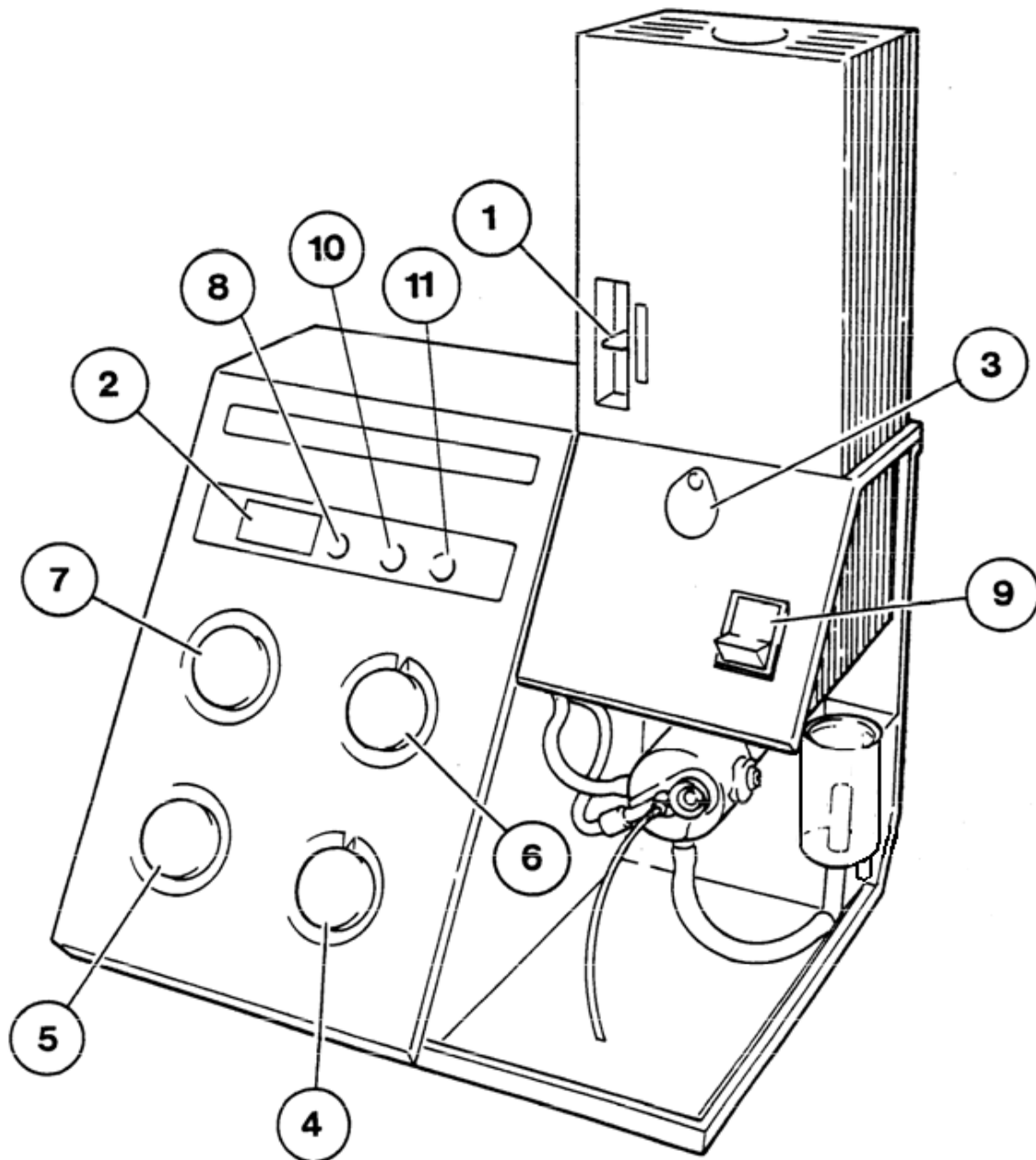

Figure 4.1 Front Panel

1. Filter selector. 2. Digital display. 3. Inspection flap. 4. Fuel adjustment control.
 5. Blank control. 6. Coarse sensitivity control. 7. Fine sensitivity control.
 8. Decimal pushbutton. 9. Power switch. 10. Power on LED. 11. Flame on LED.

Operating Instructions continued**4.2 Rear Panel Controls and Connectors**

IEC symbol advising user to refer to accompanying documentation.
Serial Plate ~symbol denotes equipment suitable for alternating current only.

Power

Three pin connector for the a.c. supply lead incorporating a voltage selector and fuse compartment.

Data output

Two colour coded chart recorder sockets. The nominal +100mV /1000 display digits output signal is on the red socket with respect to the black socket.

Gas

1/4-inch fuel inlet connector to the instrument, permanently connected to the cylinder regulator outlet. Refer to Section 2.1 for details of fuel type, pressure and flow rate.

Air

5/16-inch connector for the air inlet tubing to the instrument, from the air compressor outlet. See Section 2.1 for pressure and flow rate specifications.

Air regulator

Control to adjust the pressure of the air supply. The air pressure gauge provides a visual indication of the air pressure.

Operating Instructions continued

4.2 Rear Panel Controls and Connectors continued

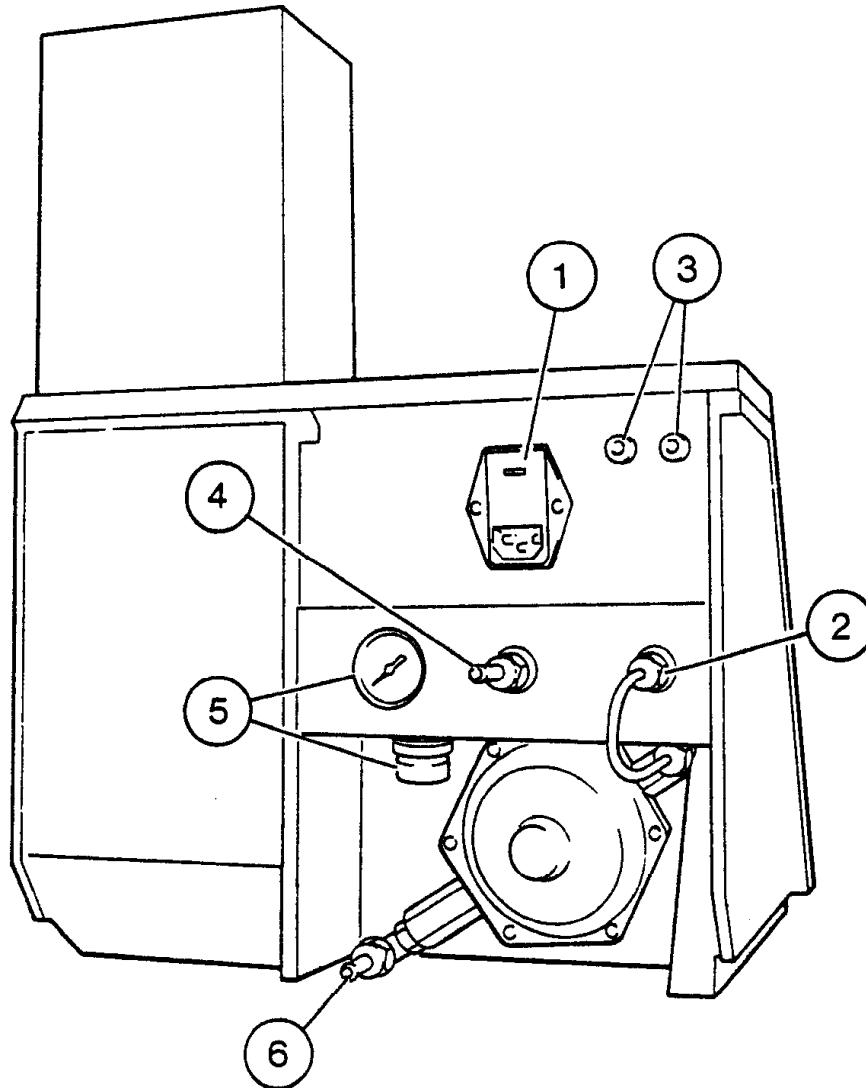

Figure 4.2 Rear Panel

- 1. Power connector and voltage selector.
- 2. Gas inlet connector.
- 3. Data output sockets.
- 4. Air inlet connector.
- 5. Air pressure gauge and air regulator adjuster.
- 6. Propane/Butane regulator inlet connector.

Operating Instructions continued**4.3 Initial Adjustment**

NOTE The following instructions assume that the air compressor is switched on and supplying the instrument with air.

1. Check that the air pressure gauge (on the rear panel) indicates a reading between 11 and 13psig. If it does not, lower the air regulator locking ring and adjust the regulator for a reading of 11 psig on the air pressure gauge. Raise the locking ring to lock the air regulator adjuster.

WARNING The air compressor should always be switched on *before* the flame is ignited. The gas will not flow without sufficient air pressure

2. Check the Gas Trap 'U' tube is filled with water; (ref. Section 2.4, paragraph 9).
3. Turn the *fuel* control fully clockwise to the closed position, but do not force it. This control is a precision assembly that will be damaged by rough handling.

WARNING Always check that the gas installation is leak-proof before initiating an ignition cycle.

4. Open the *fuel* control the required number of turns counter-clockwise as follows:-

Fuel	No. of Turns
Propane	9
Butane	11
Natural Gas	16

5. Turn on the fuel supply at source.
6. Depress the *power* switch on the front panel. The *power on* LED will illuminate, and an ignition cycle will commence.
7. If the *flame on* LED has not illuminated before the end of the ignition cycle, switch off and wait ten seconds. Then, without adjusting the fuel control, in case the instrument fuel system is not yet completely filled, switch on again to initiate another ignition cycle.
8. Repeat this cycle twice to allow sufficient time for the fuel to reach the burner then continue to paragraph 9.
9. If the *flame on* LED has not illuminated before the end of the ignition cycle, switch off the *power* switch. If using Natural Gas continue with paragraph 10. If using Propane/Butane continue with paragraph 11.
10. Remove the natural gas regulator screw cap (item 1, Figure 2.3, Appendix B). Rotate the screw head fully clockwise, and then counterclockwise exactly one and a half turns. Refit the screw cap.

WARNING *Do not* exceed this setting as this will lead to a very rich fuel mixture which may cause a flame to appear above the chimney.

11. Open the *fuel* control one turn counter-clockwise. Switch on again.
12. If the *flame on* LED still does not illuminate, repeat paragraph 11. *Do not* open the *fuel* control more than a total of 4 turns from the settings in paragraph 4.
13. If the *flame on* LED still does not illuminate, switch off and refer to Section 7.2, Troubleshooting.
14. When the *flame on* LED illuminates proceed with Section 4.4, Operating Instructions, paragraph 4.

Operating Instructions continued

4.4 Operating Instructions

NOTE For greatest accuracy and stability Sherwood Scientific recommend that a batch of diluent is made up from 1 part Diluent Concentrate and 999 parts deionised or good quality distilled water. Using diluent for setting blank and for dilution of samples and standards means that all solutions presented to the instrument contain the stability promoting ingredients contained in the diluent. Always use the same batch of diluent for the blank and the dilution of samples and standards. Store the diluent in a sealed container for not more than *five* days.

WARNING Always check that the gas installation is leakproof before initiating an ignition cycle.

1. Turn on the fuel supply at source. Switch on the Air Compressor.
2. Depress the *power* switch to switch on the instrument. The *power on* LED will be illuminated, and an ignition cycle will commence.
3. If the *flame on* LED is not illuminated at the end of the ignition cycle, refer to Section 4.3 and check the setting of the *fuel* control.
4. Set the filter selector to the required position.
5. Insert the nebuliser inlet tube in a beaker containing 100ml of diluent and allow 30 minutes for the operating temperature to stabilize. This will ensure a stable burner temperature when solutions are aspirated, after the warm up period.
6. During the warm up period prepare a set of calibration solutions to cover the required measurement range. To obtain maximum linearity Sherwood Scientific recommend that the highest standard concentration does not exceed 10ppm for Na and K and 100 ppm for Ca.
7. While aspirating diluent, adjust the *blank* control so that the display reads 0.0.
8. Aspirate the highest concentration standard.
9. Allow 20 seconds for a stable reading and then adjust *coarse* and *fine* controls for a convenient reading, e.g. 10ppm Na can be set to read 10.0 on the display.
10. Carefully adjust the *fuel* control for a maximum reading on the display, ensuring that only small adjustments are made, with a pause of several seconds between adjustments.

NOTE If you have any difficulty obtaining a maximum sodium reading proceed as follows: Open the inspection flap and adjust the *fuel* control until the flame just starts to lift off the burner. Then turn the *fuel* control back, counterclockwise, until the cones of the flame are on the burner. Close the flap and proceed with paragraph 11.

11. Remove the standard solution, wait 10 seconds, then aspirate a blank solution of diluent for 20 seconds. Adjust the *blank* control for a 0.0 reading. Remove the blank solution and wait 10 seconds.
12. Repeat paragraphs 8, 9 and 11 until the blank reading is 0.0 (within ± 0.2) and the calibration reading is within $\pm 1\%$. If a chart recorder is being used set zero on the blank solution and set span while aspirating the calibration standard.
13. Without touching the fine and coarse controls aspirate each of the remaining calibration standards for 20 seconds (starting with the lowest concentration to avoid carry over) again allowing 10 seconds between measurements. Note the value of each standard and plot the results on a graph against standard concentration on linear graph paper. Refer to example shown in Figure 4.4.

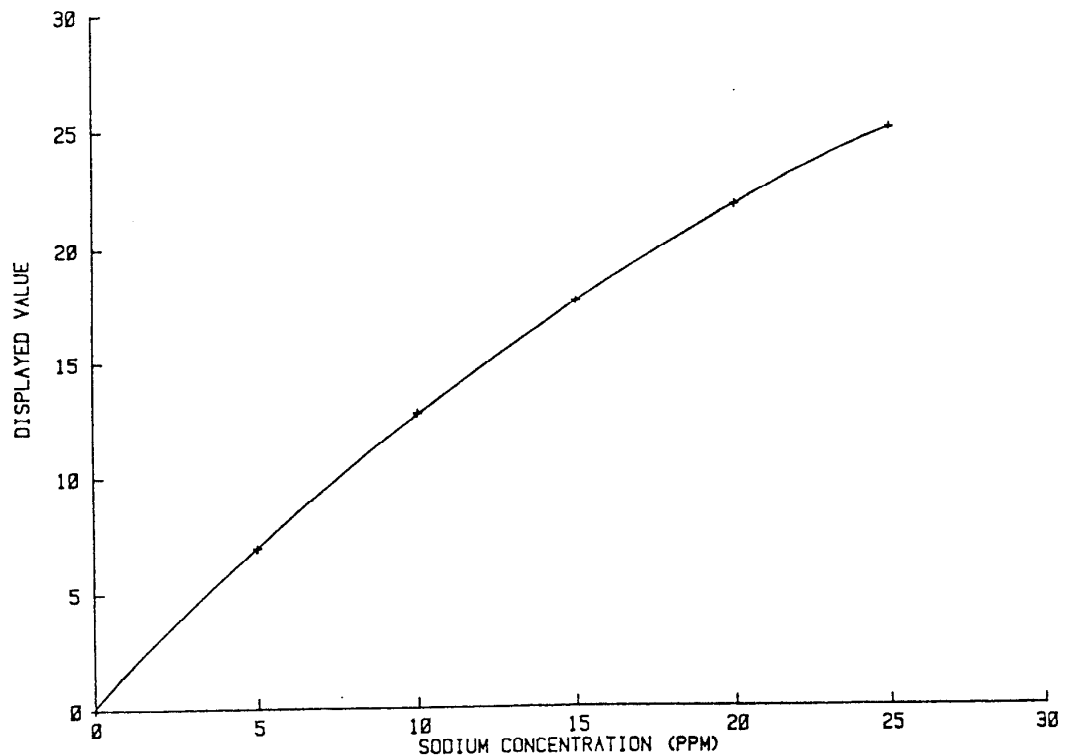
Operating Instructions continued**4.4 Operating Instructions** continued**Figure 4.4 Typical Calibration Curve**

14. Check calibration standards and blank readings.
15. Dilute the unknown solutions with diluent to give a concentration of the element under test within the range of the calibration standards. Several attempts might be necessary to determine the correct dilution ratio.
16. Aspirate each of the diluted unknowns for 20 seconds, then note the reading. The concentration of the element in the unknown sample can be calculated by reading the sample concentration from the calibration curve and multiplying it by the dilution factor.
17. Recalibrate the instrument by carrying out paragraphs 8 to 12. Experience in use will determine how frequently the calibration needs to be checked.

Operating Instructions continued

4.5 Shutdown Procedure

1. Aspirate Cleaning Solution diluted 1 in 100 with deionised water, for one minute.
2. Aspirate diluent for two minutes.
3. For a short-term shutdown (maximum two hours) switch off the instrument *power* switch and switch off the compressor.
4. For a longer term shutdown (overnight) turn off the fuel supply at source. When the *flame on* LED is extinguished, switch off the *power* switch, and the compressor. This ensures that the fuel pressure in the fuel tubing is at a minimum.

4.6 Operating Hints

1. The deionised or high quality distilled water used when making a batch of diluent must be free from contaminating elements. It is recommended that the same batch of diluent is used to prepare all solutions and to set blank on the instrument.
2. Greatest accuracy will be obtained by using the same dilution equipment for both standard and sample preparation.
3. Always use suitable standards for calibrating the instrument. Remember that the accuracy of the results obtained from the Model 410 depend on the accuracy and purity of the calibration standard that is used.
4. The nebuliser is a precision assembly, contributing more than any other single item to the effectiveness of your Flame Photometer. To keep it in good condition, it is essential that it is flushed with distilled water after use. This ensures that no solid matter remains in the assembly. If this procedure is carried out regularly no difficulties should be experienced.
5. Applications and Method Sheets are available from your Sherwood Scientific distributor or www.sherwood-scientific.com.
6. A guide to Flame Photometry is available from your Sherwood Scientific Distributor.

5

Operational Precautions and Limitations

5.1 General

1. Always dilute samples and standards with the same batch of diluent (made up of 1 part Diluent Concentrate and 999 parts of deionised or good quality distilled water), which contains non-ionic wetting agents.
2. The samples should not be highly viscous or non-homogeneous. If possible, samples likely to contain sediment should be filtered and then mixed to obtain a representative result.
3. Always use soap solution when checking for leaks in fuel or air lines. Do not allow fuel to flow in the presence of unguarded flames, e.g. cigarettes.
4. Always use genuine Sherwood Scientific replacement parts. Do not, for example, replace the 'U' tube with one of different material, bore or length as this will cause a deterioration in the instrument's performance.
5. Always carry out the maintenance schedules as detailed in Section 6.
6. *Do not* leave the inspection flap open, unless adjusting flame conditions, as this will allow stray light to enter the chimney.
7. The front panel of the Model 410 is impervious to a wide range of chemicals. However, strong acids and some organic solvents e.g. chloroform and phenol, may affect the finish. Any spillage should be thoroughly wiped away as soon as possible. If necessary, clean the instrument with warm, soapy water - *do not* use abrasives.

5.2 Hazards

1. All electrical instruments are potentially hazardous. With the exception of the glass chimney, there are no user maintainable parts inside the Model 410 covers. Never remove covers from the instrument, unless specific maintenance instructions are being followed.
2. Propane, butane and natural gas are highly inflammable and potentially explosive gases. Propane and butane are stored as a liquid, under pressure in a cylinder, for use with the Model 410. Such a cylinder should never be subjected to heat or mechanical shock. When handled correctly and connected to the instrument as instructed, the fuel gas is quite safe. Check hosing joints with a soap solution before allowing any naked flame in the vicinity. Never open a cylinder valve to atmosphere even on a supposedly empty cylinder.
3. The chimney cap and glass chimney and the area above the chimney can become very hot and are capable of causing severe burns. *Never view the flame from the top of the chimney, always use the inspection hole.*
4. Make sure that the air compressor is connected to the power supply and switched on before starting a flame ignition sequence. Failure to observe this precaution may result in a build up of fuel gas, which will cause a flame to appear above the chimney.

6

Maintenance

6.1 General

Under the Daily, Weekly, Monthly and Six-Monthly Maintenance headings are summaries of the work and equipment required. The tasks are detailed from Section 6.6 onwards.

For maintenance of the air compressor, dilutor and chart recorder, if used, refer to the instructions supplied with the equipment.

6.2 Daily Maintenance

EQUIPMENT REQUIRED: - *None.*

1. Empty waste container, if used.
2. Check air line for condensation, and drain if necessary.
3. Check 'U' tube is filled with deionised water.
4. Rinse nebuliser with distilled water after use.

6.3 Weekly Maintenance

EQUIPMENT REQUIRED

10 ml beaker; Stop watch; Nebuliser cleaning wire; Deproteinising Solution; Nebuliser tube and sleeve, or polythene inlet tube, as required.

1. Carry out Daily Maintenance procedure.
2. Deproteinising the system (Section 6.10).
3. Check the operation of the nebuliser (Section 6.6).

6.4 Monthly Maintenance

EQUIPMENT REQUIRED

As for weekly maintenance.

1. Carry out Daily and Weekly Maintenance procedures.
2. Check the constant head drain, mixing chamber, 'U' tube and drain tube and clean if necessary (Section 6.7). Check that the 'U' tube is refilled with deionised water on reassembly.

Maintenance continued**6.5 Six-Monthly Maintenance**

EQUIPMENT REQUIRED

As for weekly maintenance, plus the following: -

'U' tube and drain tube, Methanol; tissues; Soft lint free cloth; Cotton buds.

1. Carry out the Daily and Weekly Maintenance procedures.
2. Clean the mixing chamber, burner tube, burner and constant head & drain (Section 6.7).
3. Replace nebuliser tube, 'U' tube and drain tube.
4. Clean the optical filters and the glass chimney (Section 6.8).
5. Check the air and fuel tubing and connectors for leaks, using soap solution. Check for signs of stress cracking especially at the connectors.

6.6 Nebuliser

EQUIPMENT REQUIRED

Stop watch; 10 ml beaker; Cleaning wire; Cleaning Solution;

Stainless steel nebuliser tube and sleeve, or polythene inlet tube, as required.

Operational Check

1. Turn off the fuel supply at source.
2. Switch on the M410 and the air compressor. Check that the *flame on LED* is off.
3. Fill the beaker with deionised water, and weigh it.
4. Present the beaker of deionised water to the nebuliser tube for an accurately timed minute.
5. Reweigh the beaker and calculate the aspiration rate. If it is between 3 and 6g per minute, no further action is required. If it is too low, continue with paragraph 6. If it is too high contact your Sherwood Scientific Distributor. Do not attempt to adjust the nebuliser, as the capillary position is fixed during manufacture, and is not adjustable.

Cleaning the Nebuliser

6. Release the Nebuliser retainer (item 1, Figure 6.1) and withdraw the Nebuliser (item 2, Figure 6.1).
7. Remove the Nebuliser Inlet Tube. Insert a Cleaning Wire into the capillary tube at the rear of the Nebuliser and pull right through.
8. Insert the Cleaning Wire into the Nebuliser Inlet Tube and pull right through. Inspect the Nebuliser Inlet Tube; replace if signs of wear or accumulation of particles are apparent.
9. With the Nebuliser Inlet Tube removed, but with the Nebuliser attached to the Air Tubing, place a finger over the Nebuliser Outlet Nozzle, turn on the air supply to force any residue out of the Nebuliser's capillary tube.
10. Repeat steps 7, 8 and 9 until the aspiration rate is constant and between 3 and 6g per minute.
11. Replace the nebuliser and rinse with distilled water.

Note: - Before despatch each nebuliser is adjusted for optimum performance. This adjustment is critical and under no circumstances should you attempt to readjust or dismantle the assembly. If adjustments are made to the atomiser we shall not accept responsibility for poor performance from your Flame Photometer.

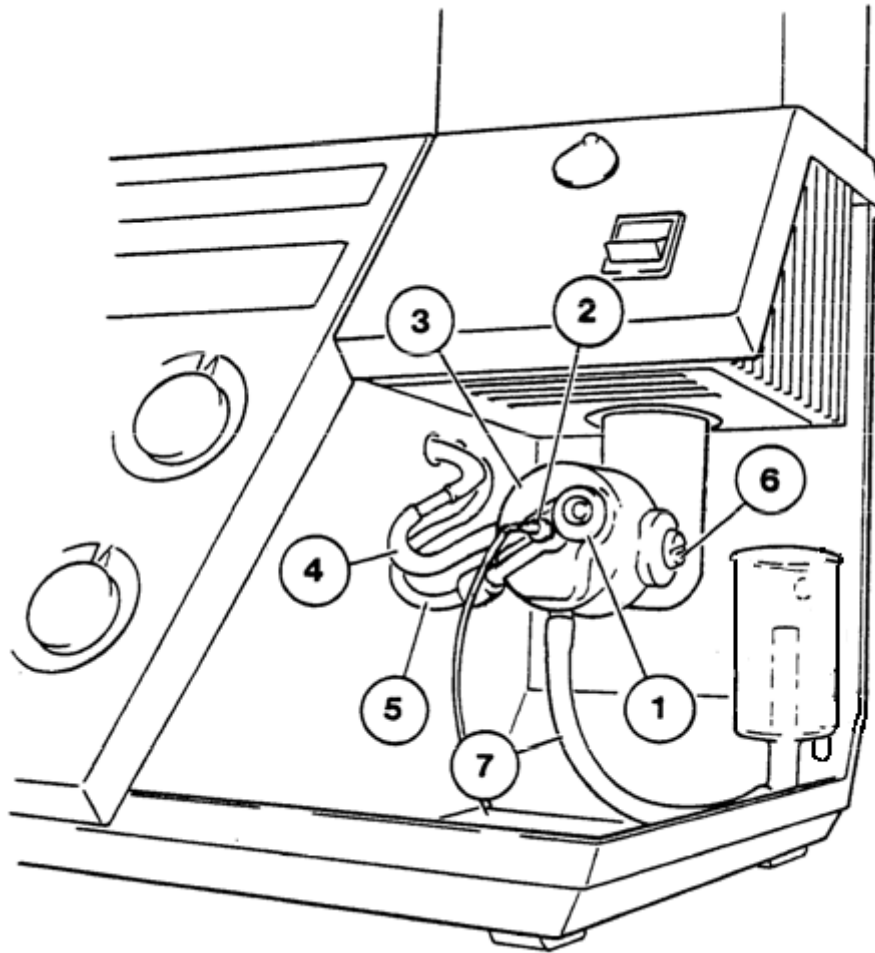
Maintenance continued**Cleaning the Nebuliser** continued**Figure 6.1** Mixing Chamber

1. Nebuliser retainer. 2. Nebuliser. 3. End cap. 4. Fuel tubing. 5. Air tubing. 6. End cap securing screw. 7. 'U' tube.

12. Fit a new length of nebuliser inlet tubing to the nebuliser. Recheck the aspiration rate, paragraphs 3, 4, and 5.
13. If nebuliser operation is still outside the specification, unscrew the air line connector and remove the nebuliser inlet tubing.
14. Soak the nebuliser in a 1 in 100 dilution of Cleaning Solution, agitating it periodically.
15. Rinse thoroughly in deionised water and shake dry.
16. Refit the nebuliser inlet tubing and the air line. Recheck aspiration rate.
17. If the nebuliser operation is still unsatisfactory, fit a new nebuliser. Do not attempt to adjust the nebuliser, as the capillary position is fixed during manufacture, and is not adjustable.

Maintenance continued**6.7 Cleaning the Mixing Chamber, Burner and Drain**

EQUIPMENT REQUIRED

Flat blade screwdriver, blade width 8 mm; Deproteinising Solution; Tissues.

1. Check that the *flame on LED* is off, the fuel is turned off at source, and the instrument and compressor are switched off.
2. Release the nebuliser retainer and withdraw the nebuliser (items 1 and 2, Figure 6.1).
3. Disconnect the fuel tubing (item 4, Figure 6.1) from the end cap connector (item 3, Figure 6.1) using a twisting movement. *Do not* pull the tubing, as this will make it grip the connector more tightly.

WARNING Use a heat resistant glove when handling the burner and burner tube if the flame has been alight within the preceding 30 minutes. Do not proceed until all the parts within the chimney are at a safe handling temperature.

4. Remove the chimney cover and lift out the glass chimney.
5. Disconnect the mixing chamber from the chimney assembly by twisting it to the right, through 40 degrees. Lower the mixing chamber and burner assembly.
6. Lift the burner tube from the mixing chamber and remove the burner.
7. Unscrew the end cap securing screw (item 6, Figure 6.1). Grasp the end cap (item 3, Figure 6.1) and remove it from the mixing chamber, with a slightly twisting action. Lift the end cap to allow the water in the 'U' tube to flow into the constant head drain. Disconnect the 'U' tube from the end cap and constant head drain.
8. Unclip the constant head drain and disconnect the drain tube.
9. Soak all the items removed from the instrument in a 1 in 100 dilution of Cleaning Solution, agitating it periodically.
10. Rinse the parts thoroughly in deionised water and dry with clean tissues.
11. Fit the burner tube to the mixing chamber, ensuring that the locating slot in the burner tube engages with the locating pin in the mixing chamber.
12. Fit the burner *pointed end downwards* into the burner tube. Rotate the burner to ensure that it is fully inserted.
13. Check the condition of the end cap 'O' ring seal. If necessary, replace the seal.
14. Replace the end cap, using a twisting movement. Align the hole with the mixing chamber screw fixing. Fit the screw (item 6, Figure 6.1).
15. Carefully position the mixing chamber, with the burner tube inside the chimney. With the burner tube fully inserted, twist the mixing chamber to the left, through 40 degrees, to lock it in position.
16. Refit the glass inner chimney and the chimney cover
17. Fit the constant head drain to the spring clip and position it so that the lip on the drain is resting on the spring clip.
18. Connect the fuel tubing to the mixing chamber end cap. Connect the 'U' tube between the mixing chamber end cap and the constant head drain. Fit the drain tube to the constant head drain.
19. Fit the nebuliser into the end cap and position the retainer to lock it.
20. Use a wash bottle to fill the 'U' tube with deionised water. Sufficient water should be used to completely fill the 'U' tube and purge it of air.

Maintenance continued**6.8 Cleaning the Optical Filters and Glass Chimney**

EQUIPMENT REQUIRED

Soft lint free cloth; Methanol; Cotton buds; Tissues; Cleaning Solution.

1. Check that the *flame on* LED is off, the fuel is turned off at source, and the 410 and compressor are switched off.

WARNING Do not proceed until all the parts within the chimney are at a safe handling temperature.

2. Lift off the chimney cap from the chimney assembly. Lift out the glass chimney.
3. Move the filter selector to the top position, and push the lever upwards and to the right. This will disengage the filter selector from the stop. Lift the filter selector out of the chimney.
4. Position the filter selector on the lint free cloth so that the coloured sides of the filters are uppermost and the thumb grip is at the top, as shown in Figure 6.2.

CAUTION Handle the optical filters only by the edges, *never* the faces.

5. Using a soft probe, (cotton bud or similar), that will not scratch the filters, push out the first filter. Examine the filter edges and note the wavelength on Figure 6.2, alongside the appropriate space. Remove the remaining two filters and mark the wavelengths on Figure 6.2.
6. Carefully wipe each filter with a cotton bud soaked in methanol.
7. Turn the filter selector over so that the large holes and filter retainers are uppermost.
8. Refer to Figure 6.2 and carefully replace the filters, mirrored sides upward, into their respective positions.
9. Refit the filter selector into position inside the chimney and slide it fully in. Check that all three positions can be selected.

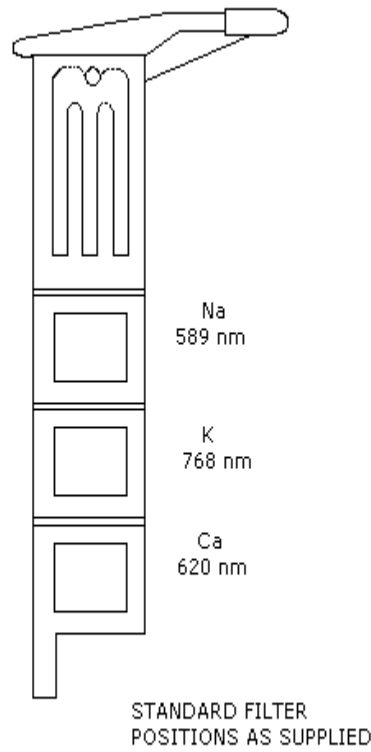
Maintenance continued**6.8 Cleaning the Optical Filters and Glass Chimney** continued**Figure 6.2 Filter Selector**

10. Soak the glass chimney in a 1 in 100 dilution of Cleaning Solution, agitating it periodically.
11. Rinse the glass chimney thoroughly in deionised water and dry with clean tissues.
12. Replace the glass chimney *with the clear strip at the bottom*. Make sure the glass chimney is seated correctly and refit the chimney cap on top of the chimney.

Maintenance continued**6.9 Voltage Selection and Fuse Replacement**

EQUIPMENT REQUIRED

Fuses.

WARNING For continued protection against fire hazard use only the same type and rating of fuse that was fitted originally to the M410 refer to instrument rear panel.

1. Check that the *flame on* LED is off, fuel is turned off at source, and the instrument and compressor are switched off.
2. Disconnect the a.c. supply lead from the a.c. supply socket.
3. Disconnect the a.c. supply lead from the *power* connector on the rear panel.
4. Open the voltage selector compartment and withdraw the voltage selector (item 1, Figure 6.3). To replace fuses continue with paragraph 5; to change the operating voltage continue with paragraph 7.
5. Slide out the two fuse holders (item 2, Figure 6.3), and remove the fuses.
6. Replace any burned out fuses and slide in the fuse holders.
7. Replace the voltage selector so that the required voltage setting is visible through the window of the compartment cover. Close the compartment cover and refit the a.c. supply lead.

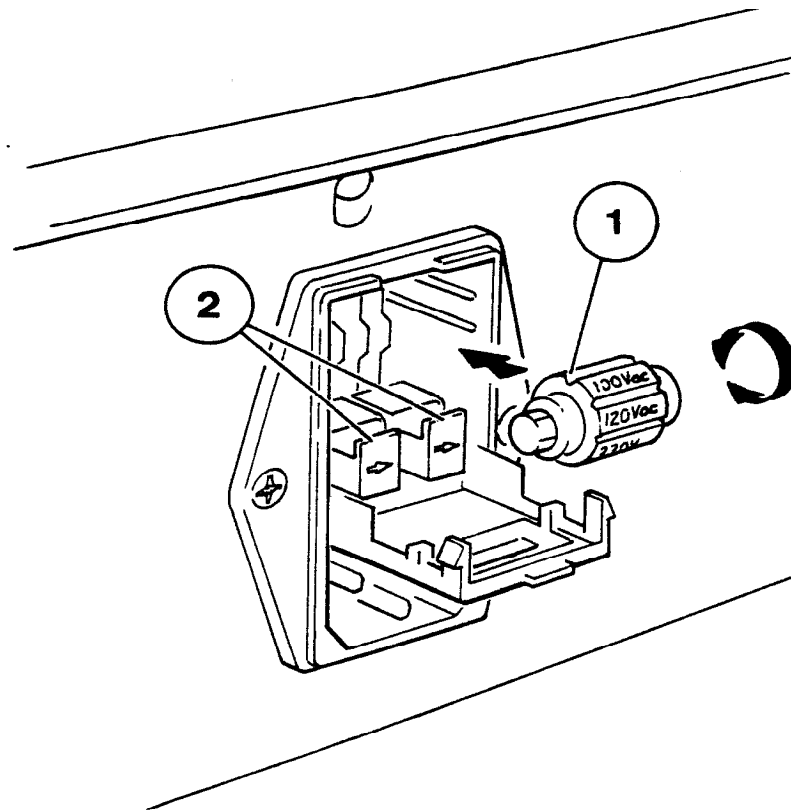

Figure 6.3 Voltage Selector and Fuse

1. Voltage selector. 2. Fuse holders

Maintenance continued

6.10 Deproteinising or Disinfecting Procedure

NOTE To deproteinise the system use Deproteinising Solution, to disinfect the system use Tubing Disinfectant.

EQUIPMENT REQUIRED

Deproteinising Solution or Tubing Disinfectant.

1. Light the flame as detailed in Section 4.4.
2. Present a beaker of Deproteinising Solution or Tubing Disinfectant to the nebuliser for 10 minutes.
3. After 10 minutes have elapsed, replace the beaker of solution with a beaker of deionised water. Flush the system for two minutes.
4. Shutdown the instrument as detailed in Section 4.5.

7

Troubleshooting

7.1 Power on LED not illuminated

Check that the instrument is connected to a working a.c. supply, and that the power switch is depressed.

Check the plug fuse and replace if necessary. Check the instrument fuses and replace if required, refer to Section 6.9.

If fault persists contact your Sherwood Scientific Distributor.

7.2 Flame on LED not illuminated

General

Ensure that the 'U' tube is filled with deionised water, refer to Figure 2.4.

Burner must be fitted with pointed end downwards, refer to Section 6.7.

Air Supply

Air compressor must be connected to an a.c. supply, and working correctly.

Check the air tubing connections from the air compressor to the instrument, refer to the air compressor manual.

Fuel Supply

There must be a compressed air flow otherwise the air pressure switch will not allow the gas to flow into the instrument.

Check that there is an adequate supply of fuel.

Fuel supply must be turned on at source. If using a long length of fuel tubing, try repeating the ignition sequence a few times to allow the fuel to fill the tubing.

If using natural gas, check the setting of the natural gas regulator, refer to Section 43.

If the fuel is propane or butane check that the regulator at the cylinder is adjusted for 2.1kg/cm² (30psig).

Check the fuel control is set correctly, refer to Section 43.

If the fuel restrictor (propane/butane only) is blocked, clean with the nebuliser cleaning wire, refer to Figure 2.1. If fault persists contact your Sherwood Scientific Distributor.

Troubleshooting continued**7.3 Unable to set display to zero**

Check that diluent is being aspirated.

The deionised water supply may be contaminated, use a better grade of deionised water.

The burner may be encrusted with salt deposits. Clean the burner as detailed in Section 67.

If using a chart recorder check that the data output connections are correct.

If fault persists contact your Sherwood Scientific Distributor.

7.4 Unable to set display to standard reading

Check the concentration of the standard being aspirated, and that the dilution ratio of this standard is correct.

Use fresh deionised water and recalibrate zero. If using low-grade deionised water the background levels may be too high.

Make sure the correct filter has been selected. If there is a chance that the optical filters may have been serviced, check that they have been fitted correctly, refer to Section 6.8.

The nebuliser may be blocked. Check the nebuliser, refer to Section 6.6.

Check the glass chimney is clean, refer to Section 6.8.

Make sure the fuel control is set correctly, refer to Section 4.3.

If the atmosphere surrounding the instrument, or air compressor inlet, is contaminated (e.g. smoke) incorrect readings may result.

If fault persists contact your Sherwood Scientific Distributor.

7.5 Unstable results

Do not use compressed air from a “communal” source or “Air Line” as this may be contaminated with oil, which will ruin the performance of the Model 410. Use a dedicated Compressor such as the Sherwood Model 851 or Model 855.

Check the concentration of the solutions being aspirated. The solutions should all contain 1 in 1000 dilution of Diluent Concentrate, refer to Section 4.4.

Check the fuel supply is adequate. Make sure the fuel control is set correctly, refer to Section 5.3.

The use of Natural Gas from a “communal source” will fluctuate as other users turn on or turn off their gas taps. Wherever possible, use bottled gas.

The nebuliser may be blocked. Check the nebuliser, refer Section 6.6.

The ‘U’ tube or drain tubing may be blocked or partially obstructed.

If the air supply tubing show signs of condensation, drain the air tubing. If this problem recurs frequently use a Model 855 air compressor with water separator.

Make sure the air compressor filter is changed regularly, refer air compressor manual.

If the atmosphere surrounding the flame photometer, or air compressor inlet, is contaminated (e.g. smoke) unstable readings may result. A similar effect may be observed if the instrument is sited in a draught. If fault persists contact your Sherwood Scientific Distributor.

Troubleshooting continued

7.6 Non-linear results

Check the concentration of the solutions being aspirated. The solutions should all contain 1 in 1000 dilution of Diluent Concentrate, refer Section 4.4. Make up fresh solutions and recheck calibration curve.

Check that the fuel supply is adequate. Make sure the fuel control is set correctly, refer Section 4.3.

The nebuliser may be blocked. Check the nebuliser, refer Section 6.6.

The 'U' tube or drain tubing may be blocked or partially obstructed.

Use fresh deionised water and recalibrate zero. If using low-grade deionised water the background levels may be too high.

If fault persists contact your Sherwood Scientific Distributor.

8

Spares and Accessories

8.1 Ordering Information

When ordering spares or accessories for your instrument, please give the following information to your Sherwood Scientific distributor.

Instrument Serial No.

Catalogue No. of Part (Cat. No.)

Description

Quantity required

This will ensure that your order is dealt with quickly and efficiently.

The number shown in the third column (Quantity) is the quantity of items that are supplied against the stated Catalog Number. If the quantity is greater than 1, then only multiples of that quantity can be supplied.

8.2 Spares and Accessories

Serial Number	Item	Quantity
420 08 102	Nebuliser	1
410 26 001	Mixing chamber and burner	1
402 12 001	End Cap Assembly	1
400 02 013	Retainer, End Cap	1
401 11 000	Constant Head and Drain	1
001 48 105	Fuse, 200mA, slo-blo	1
400 22 003	Tube, Nebuliser Inlet	1
400 20 001	Fuel restrictor	1
410 19 002	Natural gas regulator kit with filter	1
001 26 033	Sample pot, plastic, in packs of 50	1 pack
989 05 137	Sodium filter, 589.6nm	1
989 05 138	Potassium filter, 768nm	1
989 05 139	Lithium filter, 671nm	1
400 16 004	Calcium filter, 620nm, with label	1
400 16 005	Barium filter, 520nm, with label	1
410 27 001	Caesium in Holder	1
410 27 002	Rubidium in Holder	1
410 27 003	Strontium in Holder	1
410 21 001	Filter holder	1
	(recommended for use with additional filters)	1
001 08 234	Propane primary regulator, cylinder fixing	1

Spares and Accessories continued

Serial Number	ITEM	QUANTITY
001 08 439	Butane primary regulator (182H) for 32lb Calor/Caravan cylinder	1
001 08 732	Butane primary regulator for 'Gaz' type cylinder	1
001 72 114	Fuel tubing	per metre
001 72 116	Air tubing	per metre
001 08 718	'Unex' tubing clamp	1
100 99 010	Nebuliser cleaning wire, pack of 3	1 pack
851 01 001	Model 851 Air Compressor, 230V	1
851 01 000	Model 851 Air Compressor, 115V	1
855 01 001	Model 855 Air Compressor, 230V complete with water separator	1
855 01 000	Model 855 Air Compressor, 115V complete with water separator	1
410 89 001	Service Manual	1
410 86 001	Digital Interface/Lineariser Module	1
410 66 000	Flame Application Software	1
860 00 009	Model 860 Autosampler	1
475 41 100	Model 805 Dilutor	1
471 71 900	Mains Supply Lead	1
001 26 074	Disposable sample cups, 1,5ml, pack of 1000	1 pack
001 26 033	Disposable sample cups, 25ml, pack of 50	1 pack
001 92 492	Guide to Flame Photometry	1

8.3 Standard Solutions

NOTE The following solutions are available.

Serial Number	ITEM	QUANTITY
001 56 620	Flame Photometer Standard, 1000ppm Na	6 x 100ml
001 56 621	Flame Photometer Standard, 1000ppm K	6 x 100ml
001 56 622	Flame Photometer Standard, 1000ppm Li	6 x 100ml
001 56 623	Flame Photometer Standard, 1000ppm Ca	6 x 100ml
001 56 184	Cleaning Solution, 500ml	1 bottle
001 56 681	Diluent Concentrate	6 x 100ml
001 56 682	Tubing Disinfectant,	6 x 100ml
001 56 183	Deproteinising solution, 80ml, pack of 6	1 pack

Appendix A

Bibliography

Reference

1. Kolthoff, I.M., Z. Anal. Chem. 70 397 1927
2. Shohl, A.T., and Bennett, H.B. J. Biol. Chem. 78: 643 1928
3. Hald, P.M., J. Biol. Chem. 167. 499. 1947
4. Bernstein, R.E., S.Afr. J. Med. Sci. 17. 101, 1952
5. Alkemade, C.T.J., Smit J. and Verschure J.C.M. Biochimica et Biophysica Acta. 8. 562. 1952
6. Collins G.C. and Polkinthorne H., The Analyst, 77, 917 pp. 430-436, 1952
7. Dryer, R.L., Clin. Chem. 2. 112. 1956
8. Puffeles, M. and Nessim, N.E., The Analyst. 82. 976, 1957
9. Boling, E.A., J. Lab and Clin. Med. 63, 501 1964
10. Amdisen, A., Scand J. Clin. and Lab. Invest. 20 (2) 104. 1967

Appendix B

Installing a Natural Gas Regulator Kit

1. Remove the fuel restrictor (item 5, Figure 2.1) and connect the fuel tubing (item 6, Figure 2.1) directly to the mixing chamber connection.
2. Unscrew and remove the gas inlet, regulator inlet and regulator outlet connectors (items 4, 5 and 6, Figure 2.2) and remove the copper tubing (item 2, Figure 2.2).
3. Connect the regulator inlet, with connector, (item 5, Figure 2.2) to the gas inlet (item 4, Figure 2.2).

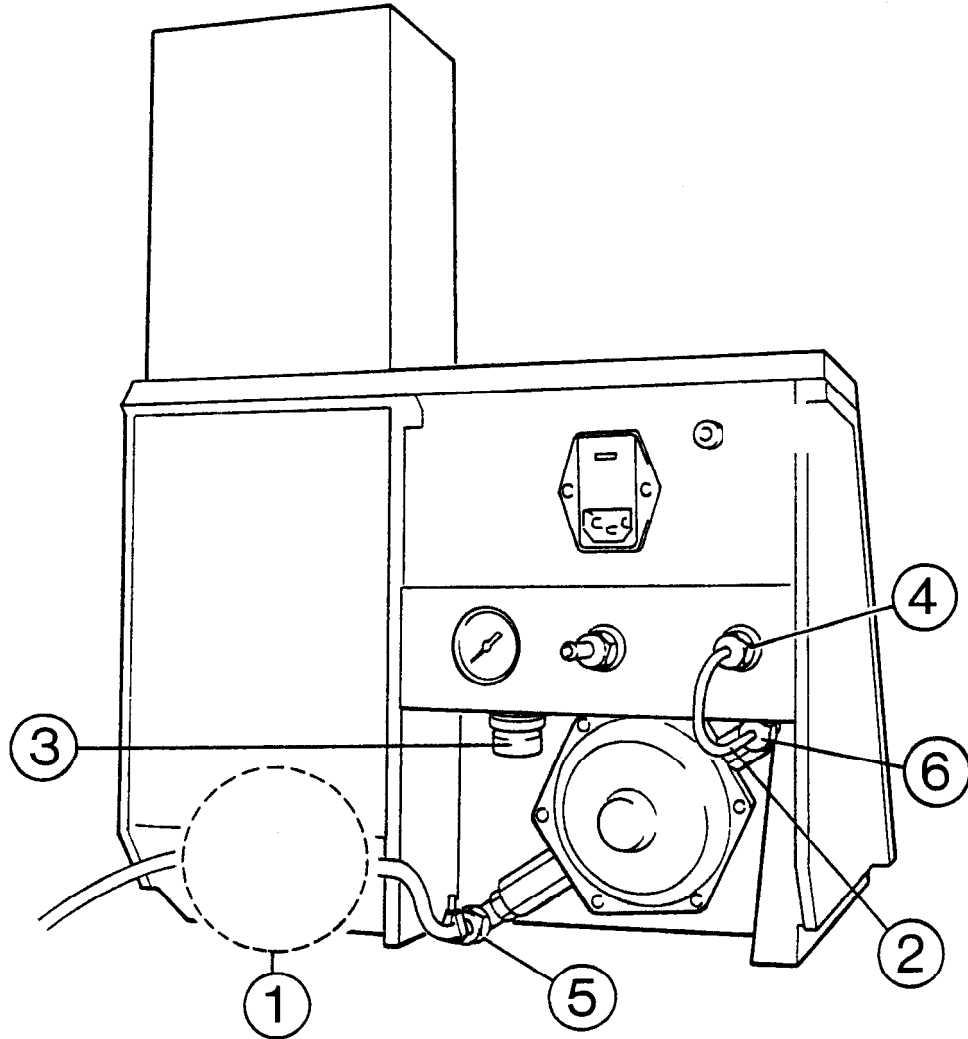
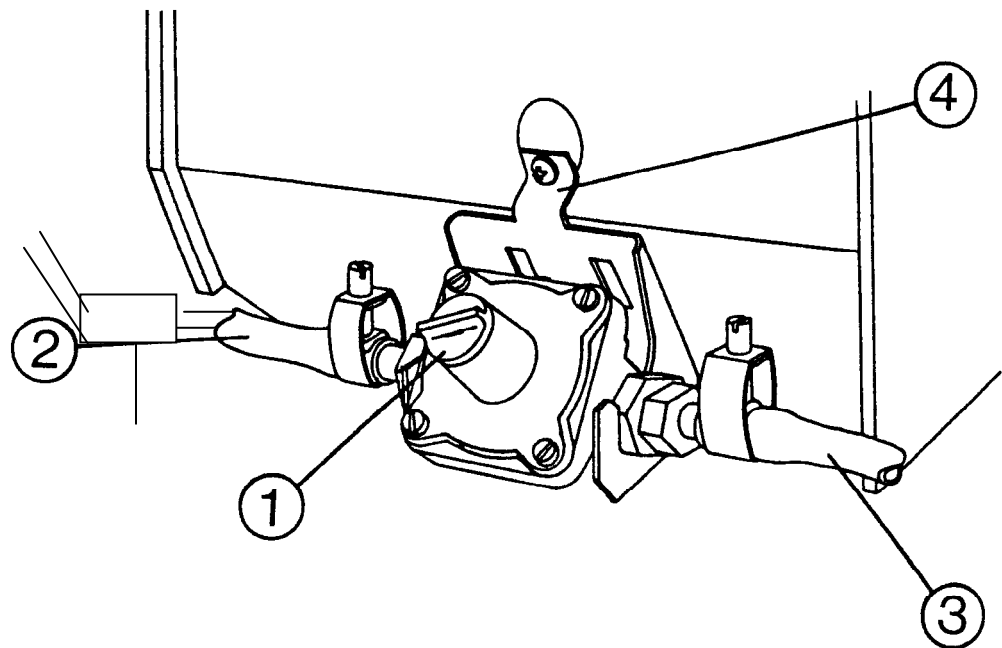

Figure 2.2 Rear Panel

1. Natural gas regulator assembly (see Figure 2.3). 2. Copper tubing.
 3. Air regulator adjuster. 4. Gas inlet connector. 5. Regulator inlet connector.
 6. Regulator outlet connector.

Appendix B continued**Installing a Natural Gas Regulator Kit** continued

4. Locate the Natural gas regulator and mounting bracket ordered as optional accessories and packed separately from the instrument. Fit the mounting bracket to the rear panel with the two screws supplied and slot in the Natural gas regulator, Figure 2.3. Make sure that the gas flow arrow on the regulator points to the right.
5. Connect the Natural gas supply to the Natural gas regulator inlet with the fuel tubing and 'Unex' clamp supplied with the instrument.
6. If it is necessary to fit the filter because of suspected dirty gas then this should be fitted before the Natural Gas regulator by cutting the rubber hose and fitting the filter in the tubing with the arrow pointing towards the regulator. Secure the tubing to the filter and regulator with the extra Unex clips supplied with the Natural Gas regulator kit.
7. Connect the Natural gas outlet tubing (supplied with the regulator) to the gas inlet connector (item 4, Figure 2.2), using the connector and nipple removed as described in paragraph 7 above bypassing the Propane/Butane regulator. Secure with 'Unex' clamp supplied.

**Figure 2.3 Natural Gas Regulator**

1. Regulator screw cap.
2. Filter in line with Rubber hose supplied with instrument.
3. Natural gas outlet tubing. 4. Mounting bracket.

8. Remove the screw cap (item 1, Figure.2.3). Rotate the screw head fully clockwise, and then counterclockwise exactly one turn.
9. Refit screw cap.

Return to point 6 of Section 2.4 on page 12.

Sherwood Scientific Limited

Product Warranty Statement

Warranty Term: 12 Months

Sherwood Scientific Ltd (Sherwood) warrants, subject to the conditions itemised within this document, through either Sherwood personnel or personnel of its authorised distributors, to repair or replace free of all charges, including labour, any part of this product which fails within the warranty time specified above, appertaining to this particular product. Such failure must have occurred because of a defect in material or workmanship and not have occurred as a result of operation of the product other than in accordance with procedures described in the instructions furnished with this product.

Conditions and specific exceptions that apply to the above statement are as follows:

1. End-user warranty time commences on the date of the delivery of product to end-user premises.
2. 'Free of all charges' statement applies only in areas recognised by Sherwood as being serviced either directly by its own personnel, or indirectly through personnel of an authorised distributor. Products purchased outside these areas requiring service during the warranty period will incur charges relative to the travel/transit costs involved. However, products purchased in such areas will be serviced during the warranty period free of all charges providing they are returned, carriage paid, to either Sherwood or by pre-arrangement to an authorised Sherwood distributor.
3. All maintenance (other than operator maintenance as described in the instructions), repairs or modifications have been made by Sherwood or Sherwood authorised personnel.
4. This product has where applicable been operated using Sherwood specified supplies and reagents.
5. Sherwood reserves the right to make any changes in the design or construction of future products of this type at any time, without incurring any obligation to make any changes whatsoever to this particular product.
6. Reagents, supplies, consumables, accessories and user maintenance items are not included in this warranty.
7. Repairs or replacement of any part failing due to abnormal conditions including the following, are excluded from this warranty:
 - a. Flood, lightning, earthquake, tornado, hurricane, or any other natural or man-made disaster.
 - b. Fire, bombing, armed conflict, malicious mischief or sprinkler damage.
 - c. Physical abuse, misuse, sabotage or electrical surge.
 - d. Damage incurred in moving the product to another location.

Product Warranty Statement (continued)

8. User agrees to permit Sherwood personnel or personnel of its authorised distributor to make changes in the product which do not affect results obtained, but do improve product reliability.

Representations and warranties purporting to be on behalf of Sherwood made by any person, including distributors and representatives of Sherwood, which are inconsistent or in conflict with the terms of this warranty (including but not limited to the limitations of the liability of Sherwood as set forth above), shall not be binding upon Sherwood unless reduced to writing and approved by an officer of Sherwood Scientific Ltd.

Except for the obligations specifically set forth in this warranty statement, in no event shall Sherwood be liable for any direct, indirect, special, incidental, or consequential damages, whether based on contract, tort or any other legal theory and whether advised of the possibility of such damages.

Neither Sherwood nor any of its third party suppliers makes any other warranty of any kind, whether expressed or implied, with respect to Sherwood Products.

Sherwood Scientific Ltd.,
1 The Paddocks,
Cherry Hinton Road,
Cambridge,
CB1 8DH,
England