



**INSTRUCTION MANUAL**

**MCO-18AC(UV)  
MCO-18AC**

**CO<sub>2</sub> Incubator**



7FB6P101567000  
(29 June 2010)



**SANYO Electric Co., Ltd.**  
5-5, Keihan-Hondori 2-Chome  
Moriguchi City, Osaka 570-8677 Japan  
Printed in Japan

# CONTENTS

INTRODUCTION	P. 2
PRECAUTIONS FOR SAFE OPERATION	P. 3
LABELS ON THE INCUBATORS	P. 6
ENVIRONMENTAL CONDITIONS	P. 7
INCUBATOR COMPONENTS	P. 8
Control panel and keypad	P. 10
Remote alarm terminal	P. 11
INSTALLATION SITE	P. 12
INSTALLATION	P. 13
Connection of CO <sub>2</sub> gas cylinder	P. 14
PREVENTING CONTAMINATION	P. 15
PRECAUTIONS FOR CULTURES	P. 16
START-UP OF INCUBATOR	P. 17
SETTING THE CHAMBER TEMPERATURE AND CO <sub>2</sub> DENSITY	P. 18
UV LAMP(MCO-18AC(UV) or MCO-18AC with MCO-18UVS3)	P. 19
Precautions when using the UV lamp	P. 20
Setting the UV lamp ON period	P. 21
Lighting the UV lamp for 24 hours	P. 22
KEY LOCK FUNCTION	P. 23
WATER LEVEL SENSOR(MCO-18AC(UV) or MCO-18AC with MCO-18UVS3)	P. 24
ALARMS, SAFETY, AND SELF-DIAGNOSIS	P. 25
SETTING OF ALARM RESUME TIME	P. 26
Operation after power failure	P. 26
ROUTINE MAINTENANCE	
Cleaning the chamber and inner attachments	P. 27
Filling the humidifying pan	P. 30
CALIBRATION	
Temperature calibration	P. 31
CO <sub>2</sub> calibration	P. 32
TROUBLESHOOTING	P. 33
DISPOSING OF THE CO <sub>2</sub> INCUBATOR	P. 34
AUTOMATIC CO <sub>2</sub> CYLINDER CHANGEOVER	P. 39
STACKING INCUBATORS	P. 40
SPECIFICATIONS	P. 42
PERFORMANCE	P. 43
SAFETY CHECK SHEET	P. 44

# INTRODUCTION

- Read this manual carefully before using the appliance and follow the instructions for safety operation.
- Sanyo never guarantee any safety if the appliance is used for any objects other than intended use or used by any procedures other than those mentioned in this manual.
- Keep this manual in an adequate place to refer to it as necessary.
- The contents of the manual will be subjected to change without notice due to the improvement of performance or functions.
- Contact Sanyo sales representative or agent if any page of the manual is lost or page order is incorrect.
- Contact Sanyo sales representative or agent if any point in this manual is unclear or if there are any inaccuracies.
- No part of this manual may be reproduced in any form without the expressed written permission of Sanyo.

## CAUTION

SANYO guarantees the product under certain warranty conditions. SANYO in no way shall be responsible for any loss of content or damage of content.

# PRECAUTIONS FOR SAFE OPERATION

**It is imperative that the user complies with this manual as it contains important safety advice.**

Items and procedures are described so that you can use this unit correctly and safely. If the precautions advised are followed, this will prevent possible injury to the user and any other person.

Precautions are illustrated in the following way:



## **WARNING**

Failure to observe WARNING signs could result in a hazard to personnel possibly resulting in serious injury or death.

## **CAUTION**

Failure to observe CAUTION signs could result in injury to personnel and damage to the unit and associated property.

Symbol shows;

-  this symbol means caution.
-  this symbol means an action is prohibited.
-  this symbol means an instruction must be followed.

Be sure to keep this manual in a place accessible to users of this unit.

< Label on the unit >

















This mark is labeled on the cover in which the electrical components of high voltage are enclosed to prevent the electric shock.

The cover should be removed by a qualified engineer or a service personnel only.













## **WARNING**

As with any equipment that uses CO<sub>2</sub> gas, there is a likelihood of oxygen depletion in the vicinity of the equipment. It is important that you assess the work site to ensure there is suitable and sufficient ventilation. If restricted ventilation is suspected, then other methods of ensuring a safe environment must be considered. These may include atmosphere monitoring and warning devices.







# **WARNING**

-  **Do not use the unit outdoors.** Current leakage or electric shock may result if the unit is exposed to rain water.
-  **Only qualified engineers or service personnel should install the unit.** The installation by unqualified personnel may cause electric shock or fire.
-  **Install the unit on a sturdy floor and take an adequate precaution to prevent the unit from turning over.** If the floor is not strong enough or the installation site is not adequate, this may result in injury from the unit falling or tipping over.
-  **Never install the unit in a humid place or a place where it is likely to be splashed by water.** Deterioration of the insulation may result which could cause current leakage or electric shock.
-  **Never install the unit in a flammable or volatile location.** This may cause explosion or fire.
-  **Never install the unit where acid or corrosive gases are present** as current leakage or electric shock may result due to corrosion.
-  **Always ground (earth) the unit to prevent electric shock.** If the power supply outlet is not grounded, it will be necessary to install a ground by qualified engineers.
-  **Never ground the unit through a gas pipe, water main, telephone line or lightning rod.** Such grounding may cause electric shock in the case of an incomplete circuit.
-  **Connect the unit to a power source as indicated on the rating label attached to the unit.** Use of any other voltage or frequency other than that on the rating label may cause fire or electric shock.
-  **Never store volatile or flammable substances** in this unit if the container cannot be sealed. These may cause explosion or fire.
-  **Do not insert metal objects such as a pin or a wire into any vent, gap or any outlet on the unit.** This may cause electric shock or injury by accidental contact with moving parts.
-  **Use this unit in safe area when treating the poison, harmful or radiate articles.** Improper use may cause bad effect on your health or environment.
-  **Turn off the power switch (if provided) and disconnect the power supply to the unit prior to any repair or maintenance** of the unit in order to prevent electric shock or injury.
-  **Do not touch any electrical parts (such as power supply plug) or operate switches with a wet hand.** This may cause electric shock.

# **WARNING**





-  **Ensure you do not inhale or consume medication or aerosols** from around the unit at the time of maintenance. These may be harmful to your health.
-  **Never splash water directly onto the unit** as this may cause electric shock or short circuit.
-  **Never put containers with liquid on the unit** as this may cause electric shock or short circuit when the liquid is spilled.
-  **Never bind, process, or step on the power supply cord, or never damage or break the power supply plug.** A broken supply cord or plug may cause fire or electric shock.
-  **Do not use the supply cord if its plug is loose.** Such supply cord may cause fire or electric shock.
-  **Never disassemble, repair, or modify the unit yourself.** Any such work carried out by an unauthorized person may result in fire, or electric shock or injury due to a malfunction.
-  **Disconnect the power supply plug if there is something wrong with the unit.** Continued abnormal operation may cause electric shock or fire.
-  **When removing the plug from the power supply outlet, grip the power supply plug,** not the cord. Pulling the cord may result in electric shock or fire by short circuit.
-  **Disconnect the power supply plug** before moving the unit. Take care not to damage the power cord. A damaged cord may cause electric shock or fire.
-  **Disconnect the power plug when the unit is not used for long periods.** Keeping the connection may cause electric shock, current leakage, or fire due to the deterioration of insulation.
-  If the unit is to be stored unused in an unsupervised area for an extended period, **ensure that children do not have access and that doors cannot be closed completely.**
-  **The disposal of the unit should be accomplished by appropriate personnel.** Remove doors to prevent accidents such as suffocation.
-  **Do not put the packing plastic bag within reach of children** as suffocation may result.

# CAUTION

-  **Use a dedicated power source** (a dedicated circuit with a breaker) as indicated on the rating label attached to the unit. A branched circuit may cause fire resulting from abnormal heating.
-  **Connect the power supply plug to the power source firmly after removing the dust on the plug.** A dusty plug or improper insertion may cause a heat or ignition.
-  **Never store corrosive substances such as acid or alkali** in this unit if the container cannot be sealed. These may cause corrosion of inner components or electric parts.
-  **Check the setting when starting up of operation after power failure or turning off of power switch.** The stored items may be damaged due to the change of setting.
-  **Be careful not to tip over the unit** during movement to prevent damage or injury.
-  **Prepare a safety check sheet** when you request any repair or maintenance for the safety of service personnel.

## LABELS ON THE INCUBATORS

Warning and caution labels are attached to the incubator. The following table describes the labels.

	This label is attached to covers that access high-voltage electrical components to prevent electric shock. Only a qualified engineer or service personnel should be allowed to open these covers.
	This symbol indicates an ultraviolet light (UV) caution.
	This symbol indicates that caution is required. Refer to product documentation for details.
	This symbol indicates a hot surface.
	This symbol indicates an earth.
	This symbol means "ON" for a power switch.
○	This symbol means "OFF" for a power switch.



# ENVIRONMENTAL CONDITIONS

This equipment is designed to be safe at least under the following conditions (based on the IEC 61010-1):

- Indoor use;
- Altitude up to 2000 m;
- Ambient temperature 5°C to 40°C
- Maximum relative humidity 80% for temperature up to 31°C decreasing linearly to 50% relative humidity at 40°C;
- Mains supply voltage fluctuations not to exceed  $\pm 10\%$  of the nominal voltage;
- Other supply voltage fluctuations as stated by the manufacturer;
- Transient overvoltages according to Installation Categories (Overvoltage Categories) II; For mains supply the minimum and normal category is II;
- Pollution degree 2 in accordance with IEC 60664.

# INCUBATOR COMPONENTS

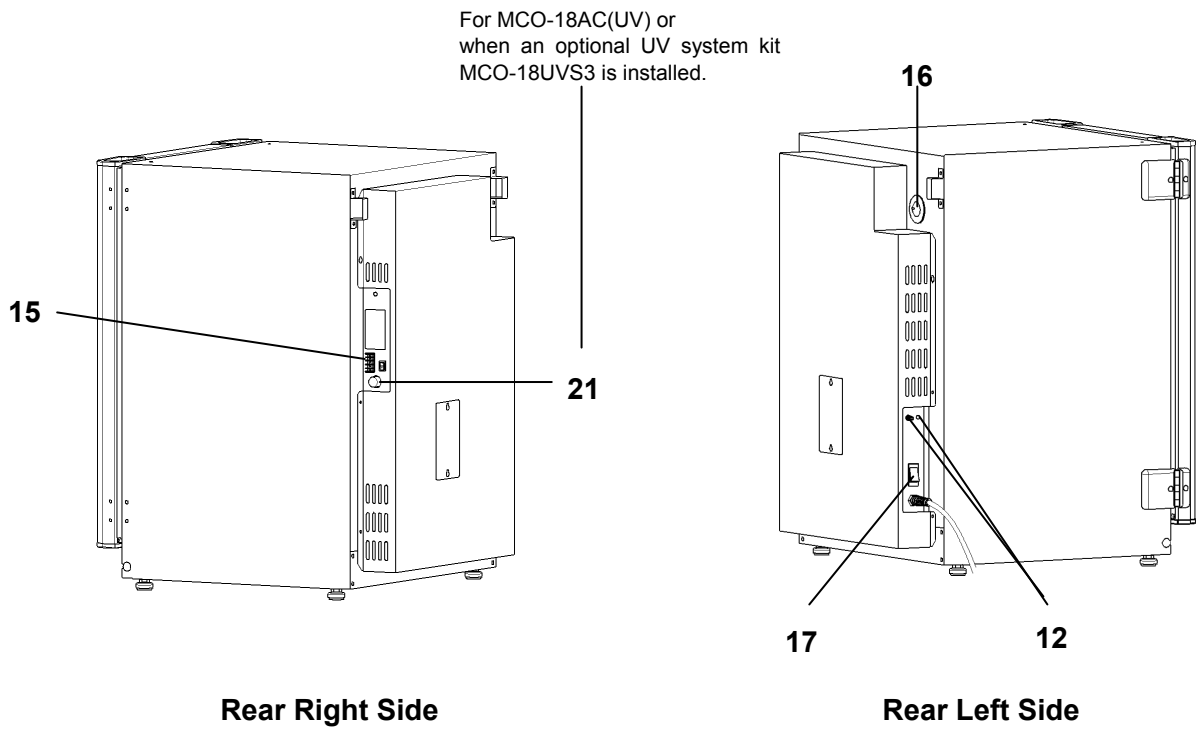
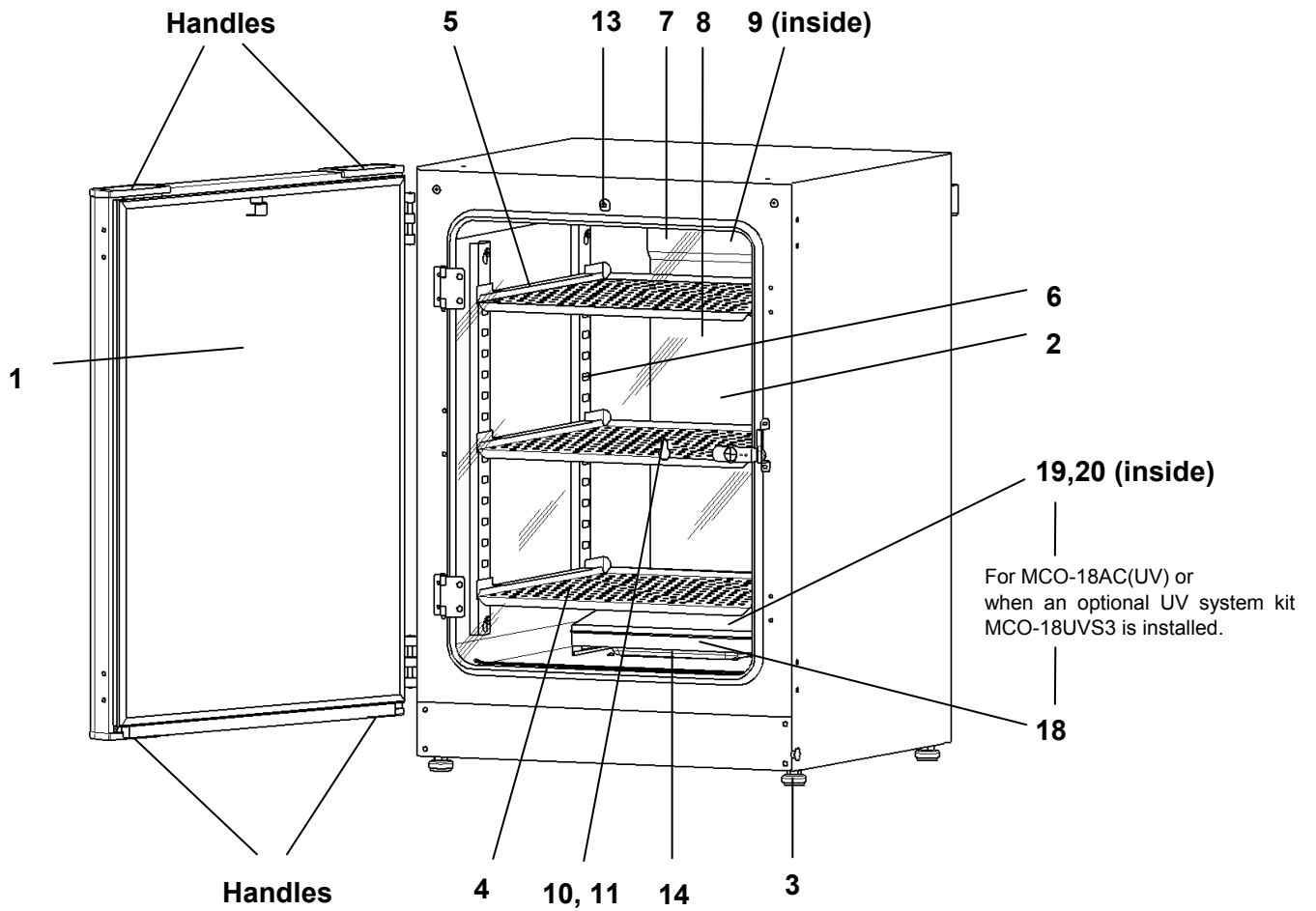

- 1. Outer door:** Sticks to frame with magnetic seal. Door heater is installed in the outer door panel. The door opening is reversible. Contact Sanyo representative or agent to change the door hinge from left to right or vice versa.
  - 2. Inner door:** Made of tempered glass, however avoid excessive impact on the glass.
  - 3. Leveling foot:** Screw type for adjusting the height. Adjust the foot so that the incubator can be level.
  - 4. Tray:** Can be pulled toward you.
  - 5. Tray support:** Can be removed by lifting the front side and pulling toward you.
  - 6. Side support:** Right and left side supports can be removed for disinfection. See page 27, 28 and 29.
  - 7. Fan cover:** Inlet of circulating air. Removable.
  - 8. Duct:** Flow path for circulating air. Removable.
  - 9. Fan (inside the rear duct):** Made from polypropylene resin. Can be disinfected by an autoclave.
  - 10. Sample air outlet:** This also functions as an internal gas outlet. Normally, cover this outlet with the sample air outlet cap.
  - 11. Sample air outlet cap:** Always attach this cap except at the time of using of sample air outlet.
- Note:** Operation without sample air outlet cap may result low humidity or condensation on the outer door.
- 12. Connecting port for CO<sub>2</sub> gas pipe:** When an optional component MCO-21GC (automatic CO<sub>2</sub> cylinder changeover system) is installed, both A and B are available. If MCO-21GC is not used, only A is available. Refer to page 14 for gas cylinder connection. Ensure that the gas pressure is set at 0.03 MPaG (0.3 kgf/cm<sup>2</sup>G, 4.3 psiG). Refer to page 39 for automatic CO<sub>2</sub> cylinder changeover system.
  - 13. Door switch:** Detects the door opening/closing and stops the circulating fan, UV lamp\* and electromagnetic valve for CO<sub>2</sub> when door is open.
  - 14. Humidifying pan:** Use sterile distilled water to fill the pan. (MCO-18AC(UV) or when an optional UV system kit MCO-18UVS3 is installed) Install the pan properly so that it can be covered with the pan cover.
  - 15. Remote alarm terminal:** Refer to page 11.
  - 16. Access port:** When not in use, cap with the silicon caps on both outside and inside.
  - 17. Power switch:** Main switch of the incubator. Also functions as an over-current breaker. The switch is covered by a switch cover to prevent the accidental push. To turn on or off the switch, remove the switch cover by loosening the screw.
  - 18. Humidifying pan cover\*:** Prevents UV light being exposed to the chamber. When filling the pan, lift the front side and take out the pan. See page 30 for details.
  - 19. UV lamp\*:** Sanyo UV lamp does not generate ozone. Never look at the UV light directly. For replacement, contact Sanyo sales representative or agent.
  - 20. Water level sensor for humidifying pan\*:** Detects the water level in the humidifying pan. See page 24 for details.
  - 21. Glow starter\*:** For UV lamp (model; FG-7P)

\*MCO-18AC(UV) or when an optional UV system kit MCO-18UVS3 is installed.

## Control panel and keypad

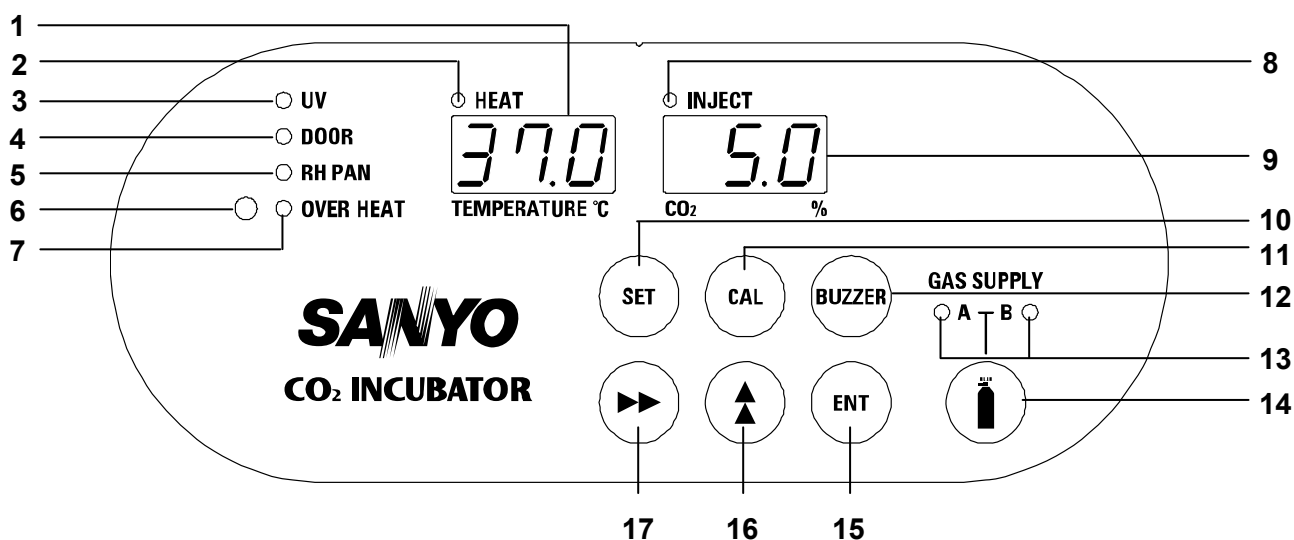

**1. Digital temperature indicator (TEMPERATURE °C):** Normally, this indicator shows the chamber temperature. In the setting mode, it shows the set value of the chamber temperature. If the self diagnostic function detects any abnormality, an error code will be displayed.

**2. Heater lamp (HEAT):** This lamp lights when the heater is energized.

**3. UV indicator (UV):** This lamp lights when the UV lamp is ON. The blink of this indicator recommends the replacement of UV lamp. See page 19 for the details. MCO-18AC(UV) or when an optional UV system kit MCO-18UVS3 is installed.

**4. Door lamp (DOOR):** This lamp lights when the outer door is open.

**5. Water level alarm lamp (RH PAN):** This lamp blinks when the water in the humidifying pan is less than approximately 0.8 liter. MCO-18AC(UV) or when an optional UV system kit MCO-18UVS3 is installed.

**6. Upper limit regulator:** This regulator is used to set the upper temperature limit.

**7. Over heat lamp (OVER HEAT):** This lamp lights when the chamber temperature reaches the upper limit set value.

**8. CO<sub>2</sub> inject lamp (INJECT):** This lamp lights when CO<sub>2</sub> gas is being injected.

**9. Digital CO<sub>2</sub> density indicator (CO<sub>2</sub> %):** Normally, this indicator shows the CO<sub>2</sub> concentration in the chamber. In the setting mode, it indicates the set value of the CO<sub>2</sub> concentration. In the calibration mode, the decimal point in the digital CO<sub>2</sub> density indicator blinks.

**10. Set key (SET):** Pressing this key to enter the setting mode, and the digits to be set will blink.

**11. Calibration key (CAL):** Pressing this key to enter the CO<sub>2</sub> calibration pre-conditioning mode. Normally when the outer door is opened, the fan motor will stop operating. This mode allows the fan motor to continue to circulate the chamber environment to ensure accurate CO<sub>2</sub> uniformity inside the chamber. At this time, by pressing this key for approximately 5 seconds, the incubator enters the temperature calibration input mode. And then pressing this key again, the incubator enters the CO<sub>2</sub> calibration input mode. See page 31 and 32 for the details. Also, used to change the UV lamp ON period. See page 21 for the details.

**Note:**

This operation affects the basic performance. When calibrating the CO<sub>2</sub> density, contact a Sanyo sales representative or agent.

**12. Alarm buzzer stop key (BUZZER):** Press this key to silence the buzzer when the alarm operates and the buzzer sounds (The remote alarm is not stopped).

**13. CO<sub>2</sub> gas supply line indicator (A/B):** The lamp for the supply line currently in use lights up provided that MCO-21GC automatic CO<sub>2</sub> cylinder changeover system (option) is installed.

**14. CO<sub>2</sub> gas supply line switching key :** This key to select CO<sub>2</sub> gas supply line is available only when an automatic CO<sub>2</sub> cylinder changeover system MCO-21GC (option) is installed. When one CO<sub>2</sub> cylinder is empty, the CO<sub>2</sub> is supplied by the other cylinder automatically.

**15. Enter key (ENT):** Pressing this key memorizes the set value in the controller.

**16. Numerical value shift key (▲):** Pressing this key in the setting mode causes the numerical value to shift. In key lock mode, pressing this key makes key lock ON or OFF. See page 23 for details.

**17. Digit shift key (▶▶):** Pressing this key in the setting mode causes the changeable digit to shift. Pressing this key more than 5 seconds enters key lock mode. See page 23 for the key lock.

## Remote alarm terminal

The terminal of the remote alarm is installed at the rear right side of the incubator. The alarm is outputted from this terminal. Contact capacity is DC 30 V, 2 A.

Contact output:

	between COM. and N.O.	between COM. and N.C.
At normal	Open	Close
At abnormal	Close	Open

**Note:**

The alarm is actuated when the power cord is disconnected from the outlet or the power switch is OFF.

- The remote alarm cannot be stopped by pressing the alarm buzzer stop key (BUZZER) since the remote alarm is not conjunct with the alarm buzzer stop key (BUZZER).

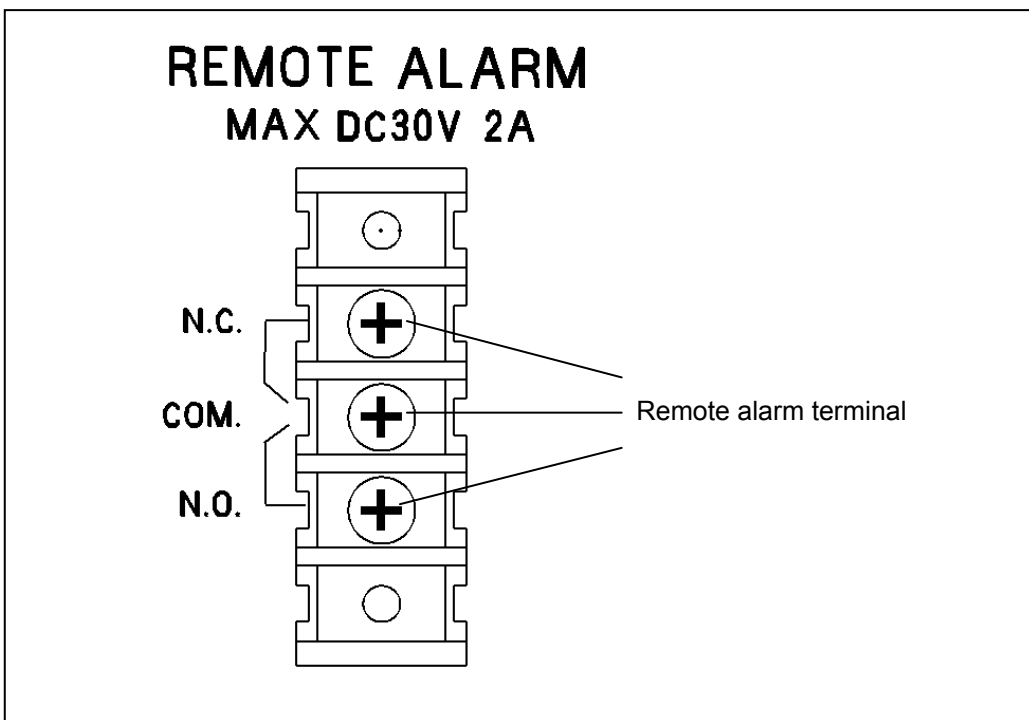

# INSTALLATION SITE

To operate this incubator properly and to obtain maximum performance, install the incubator in a location with the following conditions:

## **WARNING**

**Ventilate a room air occasionally when using CO<sub>2</sub> gas for control.** The gas density will increase in an enclosed small room and high level of gas density can be hazardous to health. In addition, avoid inhaling the chamber air directly when opening the door if CO<sub>2</sub> gas is used.

Si l'appareil est utilisé dans un endroit restreint, le niveau de la densité CO<sub>2</sub> de l'air peut s'élever et peut être nocif aux humains. Évitez d'aspirer l'air provenant de l'intérieur de l'appareil quand vous ouvrez la porte.

### ■ **A location not subjected to direct sunlight**

Do not install the incubator under direct sunlight. Installation in a location subjected to direct sunlight cannot obtain the intended performance.

### ■ **A location away from heat generating sources**

Avoid installing the incubator near heat-emitting appliances such as a heater or a boiler etc. Heat can decrease the intended performance of the incubator.

### ■ **5°C higher than the ambient temperature**

The chamber temperature must be at least 5°C higher than the ambient temperature. For example, the chamber temperature is set to 37°C, the ambient temperature must be less than 32°C. Keep the ambient temperature in adequate range.

### ■ **A location with a sturdy and level floor**

Always install the incubator on a sturdy and level floor. The uneven floor or tilted installation may cause failure or injury. Install the incubator in stable condition to avoid the vibration or noise. Unstable condition may cause vibration or noise.

## **WARNING**

**Install the incubator on a sturdy floor.** If the floor is not strong enough or the installation site is not adequate, this may result in injury from the incubator falling or tipping over.

**Select a level and sturdy floor for installation.** This precaution will prevent the incubator from tipping. Improper installation may result in water spillage or injury from the incubator tipping over.

### ■ **A location not prone to high humidity**

Install the incubator in the ambient of 80% R.H. or less humidity. Installation under high humidity may cause current leakage or electric shock.

## **WARNING**

**Do not use the incubator outdoors.** Current leakage or electric shock may result if the incubator is exposed to rain water.

**Never install the incubator in a humid place or a place where it is likely to be splashed by water.** Deterioration of the insulation may result which could cause current leakage or electric shock.

### ■ **A location without flammable or corrosive gas**

Never install the incubator in a flammable or corrosive location. This may cause explosion or fire or may result in the current leakage or electric shock by the corrosion of the electrical components.

# INSTALLATION

## 1. Remove the packaging materials and tapes

Remove all transportation packaging materials and tapes. Open the doors and ventilate the incubator. If the outside panels are dirty, clean them with a neutral detergent and wipe it up with a wet cloth.

### **WARNING**

**Do not put the packing plastic bag within reach of children** as suffocation may result.

## 2. Adjust the leveling feet

Extend the leveling feet by rotating them counterclockwise to contact them to the floor. Ensure the incubator is level.

## 3. Fix the incubator

Two fixtures are attached to the rear of the frame. Fix the frame to the wall with these hooks and rope or chain.

## 4. Ground (earth)

### **WARNING**

**Use a power supply outlet with ground (earth)** to prevent electric shock. If the power supply outlet is not grounded, it is necessary to install a ground by qualified engineers.

**Never ground the incubator through a gas pipe, water main, telephone line or lightning rod.** Such grounding may cause electric shock in the case of an incomplete circuit.

### • **Stacked module**

When the product is used in stacked module, make sure to fix the incubator by using the stacking kit

### **WARNING**

**Do not climb onto the incubator and do not put articles on the incubator.** This may cause injury by tipping or damage to the incubator. When stacking the incubator, follow the procedure shown on page 40.

### • **If not used**

When the incubator is not used, dispose the water in the humidifying pan and remove any moisture in the chamber completely. Check that the chamber is completely dry before closing the doors.

### • **Before moving the incubator**

Empty the humidifying pan completely before moving the incubator. Spilled or splashed water may cause current leakage or electric shock.

## Connection of CO<sub>2</sub> gas cylinder

### **WARNING**

Check the gas type and ensure that it is fit for the purpose. Make sure that all pipes are connected correctly and are not liable to become disconnected. Ensure that the gas pressure is set at the specified value. Improper connection of the gas pipe or use of incorrect gas pressure may result in leakage of CO<sub>2</sub> gas. Elevated level of CO<sub>2</sub> gas can be hazardous to health and may lead to asphyxiation and risk of death.

1. Use a liquefied CO<sub>2</sub> gas cylinder, not a siphon (dip tube) type. The CO<sub>2</sub> gas should be 99.5% or more pure.

2. Install a gas pressure regulator (optional accessory MCO-100L) on the cylinder. Use a regulator rated at 25 MPaG (250 kgf/cm<sup>2</sup>G, 3600 psiG) on the primary side and 0.2 MPaG (2.0 kgf/cm<sup>2</sup>G, 30 psiG) on the secondary side.

3. Using the gas supply pipe provided, connect the CO<sub>2</sub> gas pressure regulator to the connecting port for CO<sub>2</sub> gas pipe located at the rear left side of the CO<sub>2</sub> incubator.

#### **Note:**

If CO<sub>2</sub> is supplied to multiple CO<sub>2</sub> incubators from a single gas cylinder, a CO<sub>2</sub> solid will be formed in the gas pressure regulator. The gas pressure regulator safety valve will operate, and there may be an explosive sound.

#### **When the MCO-21GC is not mounted**

Using the gas supply pipe that is provided, connect the CO<sub>2</sub> gas pressure regulator for the CO<sub>2</sub> gas cylinder to CO<sub>2</sub> gas pipe connection port A on the incubator. After connecting the pipe, check to make sure that no gas is leaking.

#### **When the MCO-21GC is mounted**

Connect a pair of CO<sub>2</sub> gas cylinders with CO<sub>2</sub> gas pressure regulators independently. The gas supply line will be switched automatically. Connect the main cylinder to port A and the reserve cylinder to port B. After connecting the cylinders, check to make sure that no gas is leaking.

4. Set the CO<sub>2</sub> pressure on the secondary side to 0.03 MPaG (0.3 kgf/cm<sup>2</sup>G, 4.3 psiG) (at gas injection). Excessive pressure may cause disconnection of internal pipes inside the CO<sub>2</sub> incubator which will result in leakage of CO<sub>2</sub> gas into the atmosphere. Elevated level of CO<sub>2</sub> gas can be hazardous to health and may lead to asphyxiation and risk of death. The repair of the incubator will be necessary if the internal pipe is disconnected.

4. Check that no gas is leaking at any point where the pipe connects with the CO<sub>2</sub> regulator or the CO<sub>2</sub> incubator.

#### **Note:**

The incubator, including the gas supply pipes and services must be examined at frequent intervals to ensure they are safe. Ensure that items such as pipes are replaced if there is any sign of deterioration.



# PREVENTING CONTAMINATION

To prevent contamination of the chamber, select an appropriate location for installation as well as the complete disinfection of the chamber components.

- **Avoid hot and humid location**

Avoid location with high temperature and/or humidity as the presence of bacteria in the air is greater than in normal environment.

- **Avoid drafty location and location with many passers-by**

Avoid locations near doors, air conditioners, fans, etc., where slight breezes can facilitate the entry of bacteria into the chamber.

- **Installation in a sterile room**

To get the cultivation more efficiently, install the incubator in a sterile room.

- **Use clean containers**

The contamination is mainly caused by the containers such as Petri dishes or bottles stored in the chamber. Always keep the containers clean.

- **Always keep the chamber clean**

The condensation may be caused on the inside of the door by spilled water from humidifying pan or opening of outer door for long period. Wipe off the condensation completely with a sterile dry gauze. Especially when the culture medium is spilled, clean and disinfect the chamber immediately. Refer to page 27 "Routine maintenance" for details.

- **Keep the inside panels dry**

To protect the inside of the incubator from contamination, the inside panels should always be kept dry. If water is spilled from a humidifying pan or if the door is kept open for a long period, condensation will form on the panels, allowing germs to breed. In such a case, wipe away the water with a dry sterile gauze. Particularly, if the medium is spilled, wipe it up immediately and sterilize the area.

- **Fill the humidifying pan with sterile distilled water**

Always use sterile distilled water to fill the pan. The water level alarm lamp (RH PAN) on the control panel blinks when the water level is low. Refill the sterile distilled water to the pan when the water level alarm lamp (RH PAN) blinks. Note that when low temperature sterile distilled water is poured, the chamber temperature drops significantly. Clean the humidifying pan once a month.

- **Do not place the incubator in the direct air flow from an air conditioning system**

Air from an air conditioning system may cause condensation and lead to possible contamination.

# PRECAUTIONS FOR CULTURES

- **Do not subject to direct air flow**

Do not allow the air for air conditioning to hit the incubator or door directly. Direct hit may cause condensation or contamination.

- **Allow adequate space between the cultures**

When storing cultures in the chamber, keep the Petri dishes or bottles containing the cultures sufficiently apart from each other to allow adequate air circulation. Inadequate space may result in uneven temperature distribution and CO<sub>2</sub> concentration in the chamber.

- **Stored materials**

Never place acid or alkaline materials or materials that release corrosive gas in the chamber. Such materials can cause failure resulting from discoloration or corrosion.

- **Always shut the inner door**

Shut the inner door completely, and then shut the outer door. If the inner door is not closed completely, even if the outer door is closed, the incubator will fail to exhibit its maximum performance. And close the doors gently. Rude closing may cause spillage of medium, incomplete closing, or damage of gasket.

- **Open/close the doors gently**

Ensure you close the doors gently. Robust closing may cause spillage of medium, incomplete closing, or damage of gasket. Also, before opening the inner door, check that the UV light is OFF (MCO-18AC(UV) or when an optional UV system kit MCO-18UVS3 is installed).

- **Take care of the inside of the outer door.**

It may get hot.

- **Never lean or press on the glass.**

Broken glass due to intentional force may cause injury.

- **Alarm**

Always investigate the cause and fix the alarm condition immediately when the alarm is activated. Refer to page 25 for alarm details.

- **Fix the tray supports and trays securely**

Incomplete installation may cause injury or damage.

# START-UP OF INCUBATOR

When start the test operation or the operation, follow these steps as below.

1. Install the incubator referring to “INSTALLATION” on page 13.
2. Remove all transportation packaging materials and tapes on the attachments in the chamber. Then clean and sterilize the chamber and inner attachments. Refer to “Cleaning the chamber and inner attachments” on page 27.
3. Add approximately 1.5 L of sterile distilled water to the humidifying pan. (Refer to page 30.)
4. Turn ON the power switch on the rear left side.

**Note:**

The humidity in the incubator chamber is adjusted to the optimum setting. To prevent condensation on the surface inside chamber and the inner door, there is a low-temperature area under the humidifying pan in the bottom of chamber to recondense evaporated moisture. Condensation may occur around the humidifying pan at the bottom of the chamber, but this does not indicate a problem.

# SETTING THE CHAMBER TEMPERATURE AND CO<sub>2</sub> DENSITY

Table below shows the basic procedure for setting the chamber temperature and CO<sub>2</sub> density. The upper limit alarm temperature setting is also shown in the table. Perform key operations in the sequence indicated in the table. The example in the table is based on the assumption that the desired temperature is 37°C and CO<sub>2</sub> density is 5%. Adjustment of the upper limit regulator should be executed after the chamber temperature reaches the stable condition.

## Note:

- The incubator is set at the factory so that the chamber temperature is 37°C and CO<sub>2</sub> density is 0%.
- When starting the incubator for the first time or after not using it for an extended period of time, allow at least 8 hours for the chamber temperature, humidity, and CO<sub>2</sub> sensor to become stable after setting the desired chamber temperature at 0% CO<sub>2</sub> density. Then change the setting to the desired CO<sub>2</sub> density.

## Basic operation sequence (Example: Chamber temperature: 33°C, CO<sub>2</sub> density: 5%)

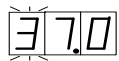
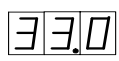
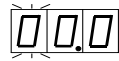
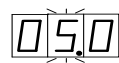
	Description of operation	Key operated	Indication after operation
1	Turn the power switch ON.	----	The current chamber temperature is displayed in the digital temperature indicator.
2	Press set key.	SET	The left digit blinks. 
3	By pressing numerical value shift key and digit shift key, set the figure to 37.0.	▶▶	When pressed, the changeable digit is shifted.
		▲	When pressed, the figure of settable digit changes. 
4	Press enter key.	ENT	Set temperature is memorized. Left digit in the digital CO <sub>2</sub> density indicator blinks. 
5	By pressing digit shift key and numerical value shift key, set the figure to 05.0.	▶▶	When pressed, the changeable digit is shifted.
		▲	When pressed, the figure of settable digit changes. 
6	Press enter key.	ENT	Set CO <sub>2</sub> density is memorized.
7	(Executed after the chamber temperature reaches the stable condition) Adjust upper limit regulator so that the alarm temp. is 1°C higher than set temperature.	----	In the digital CO <sub>2</sub> density indicator, HI is displayed. In the digital temperature indicator, upper limit temp. is displayed. The upper limit temp. can be changed by turning upper limit regulator.
8	Press enter key.	ENT	This is the end of set mode and the indicators display current temperature and CO <sub>2</sub> density.

## Note:

- In each set mode, if the change of the setting is not necessary, pressing set key (SET) skips to next set mode.
- When the CO<sub>2</sub> density is set to 00.0, the control is OFF regardless of chamber density.
- The upper limit temperature set value will change when the regulator is turned even if the incubator is not in set mode, because the alarm circuit is an independent circuit.
- In each set mode, the indicator returns to the current temperature and CO<sub>2</sub> density display mode automatically when 90 seconds has passed without any key operation.

# UV LAMP (MCO-18AC(UV) or MCO-18AC with MCO-18UVS3)

The clauses below are applicable when the model is MCO-18AC(UV) or an optional UV system kit MCO-18UVS3 is installed.

A UV lamp is located inside the duct to sterilize the water in the humidifying pan and air circulating in the chamber.

Following shows precautions and instructions about the UV lamp.

- When all chamber attachments are installed correctly, only the inside of the duct and the inside of the humidifying pan cover are exposed to UV light.
- Correctly install all of the chamber attachments when starting a cell culture, and never turn ON the UV lamp when the humidifying pan cover is removed.
- Always install the humidifying pan cover even when using the incubator without turning ON the UV lamp. Leaving the cover uninstalled will affect the chamber temperature distribution and the humidity recovery performance.
- The UV lamp stays lit for a preset period of time after the outer door is closed. The default setting is for 5 minutes. The period can be changed when necessary as shown in the page 21.
- If the outer door is not opened for at least 12 consecutive hours, the UV lamp will light for the preset time period every 12 hours. The period can be changed when necessary as shown in the page 21.
- When checking the UV lamp operation, open the outer door and push the door switch with the inner door closed. The visible blue light can be checked under the humidifying pan cover. The UV light is harmful to eyes. Never turn on the UV light with the inner door or humidifying pan cover opened.
- The recommended replacement time for the UV lamp (i.e., when the UV output ratio drops to approx. 70% of its initial value) is when the accumulated ON time reaches 1,000 hours. When the accumulated ON time reaches approximately 1,000 hours, the UV indicator blinks (when the UV lamp is not lit). It is recommended that the UV lamp be quickly replaced at this point. Contact a Sanyo sales representative or agent for information on replacing the UV lamp.
- If the UV lamp burns out, E18 is displayed on the digital temperature indicator. If this occurs, replace the UV lamp. When replacing the UV lamp, replace the glow starter (type FG-7P) at the same time. Contact a Sanyo sales representative or agent for information on replacing the UV lamp.

## Precautions when using the UV lamp

The clauses below are applicable when the model is MCO-18AC(UV) or an optional UV system kit MCO-18UVS3 is installed.



### **WARNING**

**Do not look directly at UV light.** UV light is harmful to the eyes.

- **Always use the humidifying pan and humidifying pan cover.**

The humidifying pan and cover prevent UV light from escaping. Always use them even when not humidifying. To check whether the UV lamp is lit, open the outer door and then press the door switch with the inner door still closed. Visible blue light can be confirmed from the front of the humidifying pan cover. UV light is harmful to the eyes, so do not light the UV lamp when the inner door or humidifying pan cover is open.

- **Be careful when handling the UV lamp.**







There is a UV lamp inside of the duct. Be careful not to damage it when installing or removing chamber attachments or the humidifying pan.

## Setting the UV lamp ON period

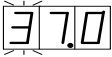
The clauses below are applicable when the model is MCO-18AC(UV) or an optional UV system kit MCO-18UVS3 is installed.

Follow the procedure below when changing the setting of the UV lamp ON period.

### Basic operation sequence (Example: change of UV lamp ON period from 5 minutes to 3 minutes)

	Description of operation	Key operated	Indication after operation
1	Press calibration key for 5 seconds.	CAL	The left digit in the digital temperature indicator is blinked. 
2	By pressing numerical value shift key and digit shift key, set the figure to F01.		When pressed, the figure of settable digit changes.
			When pressed, the changeable digit is shifted. 
3	Press enter key.	ENT	The current setting is displayed in the digital CO <sub>2</sub> density indicator. 
4	By pressing numerical value shift key and digit shift key, set the figure to 003.		When pressed, the figure of settable digit changes. 
5	Press enter key.	ENT	Set value is memorized and the display return to normal display mode.

- The UV timer can be set from 0 to 30 min. The default setting is for 5 min. When the UV timer is set to zero, the UV lamp will not light.
- If the outer door is opened while the UV lamp is lit, the lamp will turn OFF. Then, when the door is closed, the lamp will light for the preset period of time.
- If the UV lamp ON time is set for longer than 5 minutes or if only the outer door is repeated opened and closed, condensation may occur in the chamber and may affect temperature distribution. It will also shorten the service life of the UV lamp.
- When replacing the UV lamp, contact a Sanyo sales representative or agent.







Pressing calibration key (CAL) for about 5 seconds leads the calibration mode. In the calibration mode, the calibration of temperature and CO<sub>2</sub> density is possible. Wrong key operation affects the basic performance. Never touch any other keys on the control panel in the event of pressing calibration key (CAL) accidentally. After about 90 seconds, the incubator returns to chamber temperature display mode automatically.

## Lighting the UV lamp for 24 hours

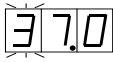
The clauses below are applicable when the model is MCO-18AC(UV) or an optional UV system kit MCO-18UVS3 is installed.

If the chamber has been contaminated by dirt or by spilling the medium, use the following procedure to decontaminate the chamber by lighting the UV lamp for 24 hours.

1. Remove all attachments from the chamber, including the trays, tray supports, side supports, fan cover, duct, fan, humidifying pan, and humidifying pan cover. Clean all the attachments in an autoclave or with disinfectant alcohol.
2. Clean and wipe off inside the chamber with disinfectant alcohol.
3. Set the CO<sub>2</sub> density to 0% and set the UV 24-hour lighting mode.

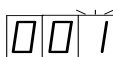
	Description of operation	Key operated	Indication after operation
1	Press calibration key for 5 seconds.	CAL	The left digit in the temperature indicator blinks. 
2	By pressing numerical value shift key and digit shift key, set the figure to F02.		When pressed, the figure of settable digit changes.
			When pressed, the changeable digit is shifted. 
3	Press enter key.	ENT	"000" is displayed in the digital CO <sub>2</sub> density indicator. 
4	By pressing numerical value shift key, set the figure to 001.		When pressed, the figure of settable digit changes. 
5	Press enter key.	ENT	Set value is memorized and the display returns to normal display mode.

- This procedure must be performed only with the outer door closed and the UV lamp turned OFF.
- The UV lamp will light continuously for 24 hours after this parameter is set. The setting is canceled if the outer door is opened. Perform the above procedure to set the 24-hours lighting mode again when opening the outer door.
- The incubator keeps running with set temperature and CO<sub>2</sub> density during UV lighting.
- Install the attachments after completion of the 24-hour lighting mode.

**Note:** Set the upper limit alarm temperature to at least 10°C higher than the chamber set temperature when using the 24-hour lighting mode of UV lamp. The 24-hour lighting mode may cause an automatic chamber temperature alarm because the temperature of the chamber will increase.



Pressing calibration key (CAL) for about 5 seconds leads the calibration mode. In the calibration mode, the calibration of temperature and CO<sub>2</sub> density is possible. Wrong key operation affects the basic performance. Never touch any other keys on the control panel in the event of pressing calibration key (CAL) accidentally. After about 90 seconds, the incubator returns to chamber temperature display mode automatically.





# KEY LOCK FUNCTION

This incubator is provided with a key lock function. When the key lock is ON, change of temperature or CO<sub>2</sub> density setting through the key pad is not available.

**Note:** The key lock is set in OFF mode (L0) at the factory.

Display	Mode	Function
	Key lock is OFF	Enable to change of temperature and CO <sub>2</sub> setting
	Key lock is ON	Disable to change of temperature or CO <sub>2</sub> setting

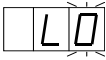
## Procedure for key lock setting (change from key lock OFF to key lock ON)

	Description of operation	Key operated	Indication after operation
1		----	The current chamber temperature and CO <sub>2</sub> density are displayed.
2	Press digit shift key for 5 seconds.		L0 is displayed in the temperature indicator. 
3	Press numerical value shift key and scroll the figure to 1.		When pressed, the figure of settable digit changes. 
4	Press enter key.	ENT	The key lock is set to ON. The current chamber temperature is displayed.

**Note:**

- The key lock function is available for temperature and CO<sub>2</sub> density setting.
- To cancel the key lock, set to L0 in the above procedure.

# WATER LEVEL SENSOR (MCO-18AC(UV) or MCO-18AC with MCO-18UVS3)

Water level sensor for the humidifying pan is used with the MCO-18AC(UV) or the MCO-18AC with an optional UV system kit MCO-18UVS3 installed. The sensor is set in active position with respect to the installation of the humidifying pan. Take care not to damage the sensor at the time of removal or installation of the humidifying pan.

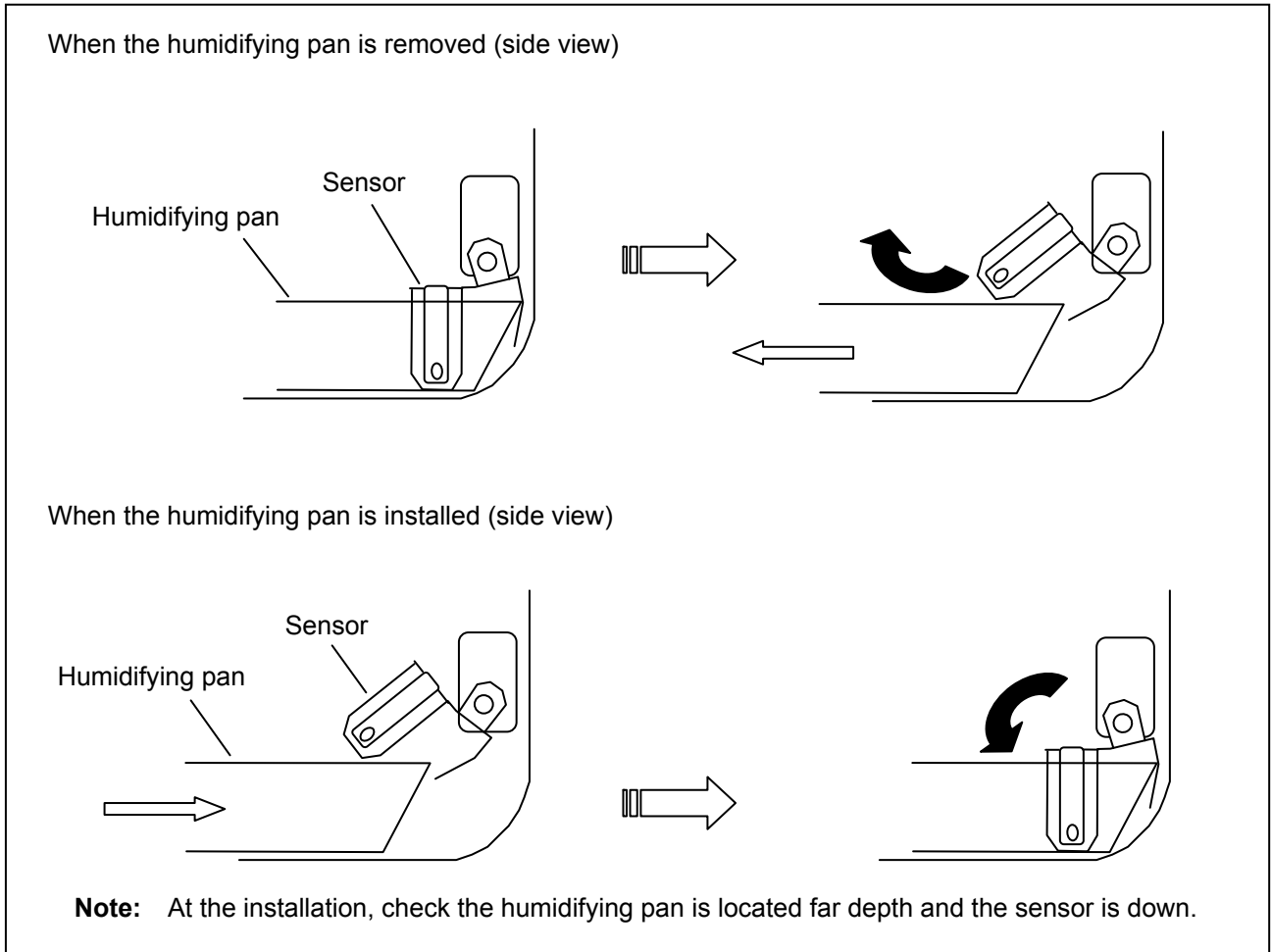

**Note:**

- Lift the sensor before installing the humidifying pan if the sensor is in lower position after maintenance.
- At the time of installation of humidifying pan, check that the pan is set properly and sensor is down in the pan. The water level alarm lamp (RH PAN) blinks if the sensor is not down completely. In this case, set the pan again in adequate location.
- The sensor detects the water level every 30 minutes. In addition, detection is executed after operation of the outer door. It takes several seconds to detect the water level. Therefore, the water level alarm lamp may blink a few times after the outer door is closed with the humidifying pan filled sufficiently.

**⚠ CAUTION**

The foreign particles on the water surface adhere to the water level sensor and its fittings by the capillary action because the sensor is always in the water. The adhered foreign particles degrade the sensor performance and the water level alarm lamp may blink with the enough water in the humidifying pan. At the cleaning, take care not transmit the excessive force to the sensor lead wire.

# ALARMS, SAFETY, AND SELF-DIAGNOSIS

The incubator supports the following alarms, safety functions, and self-diagnostic functions.

## Alarms, safety and self-diagnosis for culture operations

Alarm or safety function	Conditions	Indication	Buzzer	Safety operation
Upper limit temperature alarm	If the chamber temperature exceeds the upper limit alarm temperature set value.	Over heat lamp lights. E12 or E16 and chamber temperature are displayed alternately.	Continuous tone	Heater OFF Remote alarm
Automatic set temperature alarm	If the chamber temperature deviates from the set temperature by $\pm 1^{\circ}\text{C}$ or more.	All digits on the temperature indicator blink.	Intermittent tone with 15 minutes delay.	Remote alarm with 15 minutes delay
Automatic set CO <sub>2</sub> density alarm	If the chamber CO <sub>2</sub> density deviates from the set value by $\pm 1\%$ or more.	All digits on the digital CO <sub>2</sub> density indicator blink.	Intermittent tone with 15 minutes delay.	Remote alarm with 15 minutes delay
Door check	The outer door is open.	Door lamp lights	----	Fan motor OFF CO <sub>2</sub> valve is closed UV lamp OFF* (60 seconds after) Heater OFF
Auto-return	When there is no key pressing in each setting mode for 90 seconds.	Normal display mode.	----	The setting mode is canceled.
Key lock	When the key lock is "ON".	----	----	The setting is disabled.
CO <sub>2</sub> gas cylinder empty	If the CO <sub>2</sub> density does not increase when the gas valve is opened.	E01 is displayed alternately with the temperature on the digital temperature indicator.	Intermittent tone	Remote alarm
Gas line changeover	When the gas supply line is switched. (only when MCO-21GC is installed)	E01 is displayed alternately with the temperature on the digital temperature indicator. CO <sub>2</sub> gas supply line indicator of empty blinks.	Intermittent tone	Gas supply line is altered. Remote alarm
Chamber temperature sensor abnormality	If the temperature sensor is disconnected.	E05 is displayed alternately with the temperature on the digital temperature indicator.	Intermittent tone	Heater OFF Remote alarm
	If the temperature sensor is short circuited.	E06 is displayed alternately with the temperature on the digital temperature indicator.		
Ambient temperature sensor abnormality	If the ambient temperature sensor is disconnected.	E09 is displayed alternately with the temperature on the digital temperature indicator.	Intermittent tone	Remote alarm
	If the ambient temperature sensor is short circuited.	E10 is displayed alternately with the temperature on the digital temperature indicator.		
CO <sub>2</sub> sensor abnormality	If the output voltage of the CO <sub>2</sub> sensor is abnormal.	E11 is displayed alternately with the temperature on the digital temperature indicator.	Intermittent tone	CO <sub>2</sub> valve is closed Remote alarm
Main heater abnormality	If the upper limit alarm temperature alarm operates, or if the main heater is open circuit, or the main heater relay short circuit.	E12 is displayed alternately with the temperature on the digital temperature indicator.	Intermittent tone	Remote alarm
Bottom heater abnormality	If the bottom heater goes open circuit, or the bottom heater relay short circuit.	E13 is displayed alternately with the temperature on the digital temperature indicator.	Intermittent tone	Remote alarm
Door heater abnormality	If the door heater goes open circuit, or the door heater relay short circuit.	E14 is displayed alternately with the temperature on the digital temperature indicator.	Intermittent tone	Remote alarm
Disconnection of sensor for each heater	If the relay of main heater, bottom heater or sensor box heater goes open circuit.	E16 is displayed alternately with the temperature on the digital temperature indicator.	Intermittent tone	Remote alarm
Low humidifying Water*	If the water in the humidifying pan is about 0.8 liter.	Water level alarm lamp (RH PAN) blinks.	----	----
UV lamp failure*	When the UV lamp is burned out.	E18 is displayed alternately with the temperature on the digital temperature indicator.	Intermittent tone	Remote alarm
Recommendation of new UV lamp*	The accumulated ON time is over about 1,000 hrs.	UV indicator blinks when UV lamp is OFF.	----	----

\*MCO-18AC(UV) or when an optional UV system kit MCO-18UVS3 is installed.

- The alarm can be canceled by pressing the alarm buzzer stop key (BUZZER), but the remote alarm cannot be stopped. And the upper limit temperature alarm cannot be silenced with the alarm buzzer stop key (BUZZER).
- E01 is cleared automatically when the gas is connected correctly and the buzzer is silenced with the alarm buzzer stop key (BUZZER). When MCO-21GC is installed, press the alarm buzzer stop key (BUZZER) to silence the alarm after changeover of gas supply line.
- If one of E05 to E18 (except for E12, E13, and E14) is displayed, contact a Sanyo sales representative or agent.

# SETTING OF ALARM RESUME TIME

The alarm buzzer is silenced by pressing alarm buzzer stop key (BUZZER) on the control panel during alarm condition (The remote alarm is not stopped).

The buzzer will be activated again after certain suspension if the alarm condition is continued (The remote alarm continues). The suspension time can be set by following the procedure shown in the table below.

The example in the table is based on the assumption that the desired duration is 20 minutes.

**Note:** The duration is set in 30 minutes at the factory.

**Table Changing procedure for alarm resume time (Ex: change from 30 minutes to 20 minutes)**

	Description of operation	Key operated	Indication after operation
1		----	The current chamber temperature is displayed.
2	Press calibration key for 5 seconds.	CAL	The left digit blinks.
3	Set the figure to F25 with the numerical value shift key and digit shift key.	▲	When pressed, the figure of settable digit changes.
		▶▶	The settable digit is shifted.
4	Press enter key.	ENT	The current setting is displayed. The middle digit blinks.
5	Set the figure to 020 with the numerical value shift key.	▲	When pressed, the figure of settable digit changes.
6	Press enter key.	ENT	The setting is memorized and the current chamber temperature is displayed.

- The settable alarm resume time are 0, 10, 20, 30, 40, 50, or 60 minutes (The setting is 000, 010, 020, 030, 040, 050 or 060 respectively). The buzzer would not reset if the reset time is set in 000.
- It is recommended to set the alarm resume time when the incubator is not under alarm condition. The setting during alarm condition is effective on the next alarm condition.
- The setting cannot be changed during power failure.
- The remote alarm during power failure cannot be stopped.
- The set mode returns to the temperature display mode automatically when 90 seconds has passed without any key operation. In this case, any setting before pressing enter key is not memorized.

Pressing calibration key (CAL) for about 5 seconds leads the calibration mode. In the calibration mode, the calibration of temperature and CO<sub>2</sub> density is possible. Wrong key operation affects the basic performance. Never touch any other keys on the control panel in the event of pressing calibration key (CAL) accidentally. After about 90 seconds, the incubator returns to chamber temperature display mode automatically.

## Operation after power failure

The set value is memorized by nonvolatile memory. Accordingly, the incubator resumes the operation with setting before power failure.

# ROUTINE MAINTENANCE

## Cleaning the chamber and inner attachments

When the chamber of the incubator is contaminated, the chamber and internal attachments should be cleaned and sterilized as follows.

### **⚠ WARNING**

Before performing any repairs or maintenance, **turn OFF the power switch and unplug the incubator.** Failure to do so may result in electric shock or injury.

**Be careful not to inhale chemicals, vapors or aerosols when cleaning the incubator.** Doing so may be harmful to health.

### **⚠ CAUTION**

**Wear rubber gloves when performing maintenance on the chamber.** Failure to wear gloves may result in cuts or abrasions from sharp edges or corners.

#### **Note:**

Be careful not to damage the water level sensor or the UV lamp in the chamber duct (if the MCO-18AC(UV) or an optional UV system kit MCO-18UVS3 is installed).

Do not use detergents or antiseptic solutions with acid, alkali, or chlorine. Doing so may cause discoloration, corrosion, or rusting.

1. Close the valve of the CO<sub>2</sub> gas cylinder and turn off the power to the incubator.
2. Open the outer door. Remove 2 pins fixing the inner door hinge and remove the inner door.
3. Pull out the all trays. (See Fig. 1.)
4. Lift the front of the tray supports and pull them out. (See Fig. 2.)
5. (MCO-18AC(UV) or when an optional UV system kit MCO-18UVS3 is installed)  
Lift the humidifying pan cover off from the pins on the rear side. (See Fig. 3.)

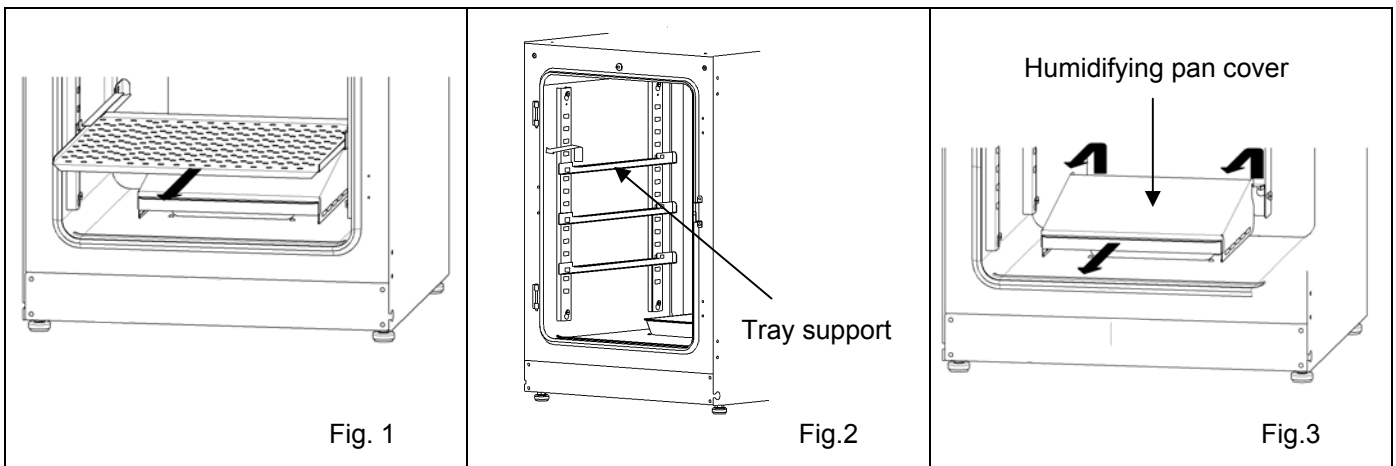

6. Pull out the humidifying pan. (See Fig. 4.)

7. Loosen the two screws securing the fan cover and take off the fan cover. (See Fig. 5.)

8. Lift the duct and remove it from the pins on the rear side. (See Fig. 6.)

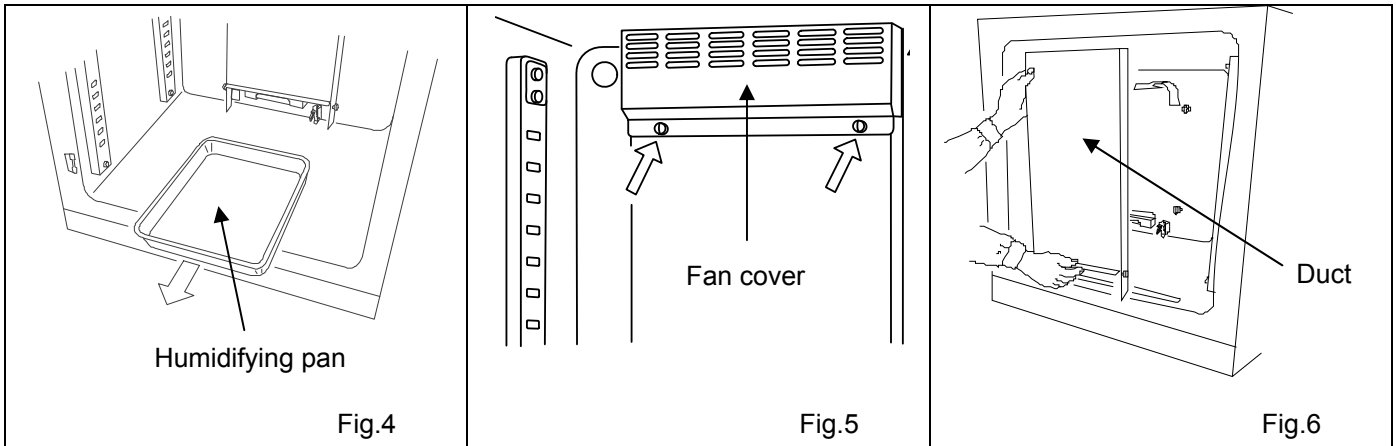

9. Remove the fan by pulling out the central spring and then by pulling out the fan. (See Fig. 7.)

10. Remove the screw securing the clamp for the side support and remove the clamp. (See Fig. 8.)

11. Lift the side support off of the pins. (See Fig. 9.)

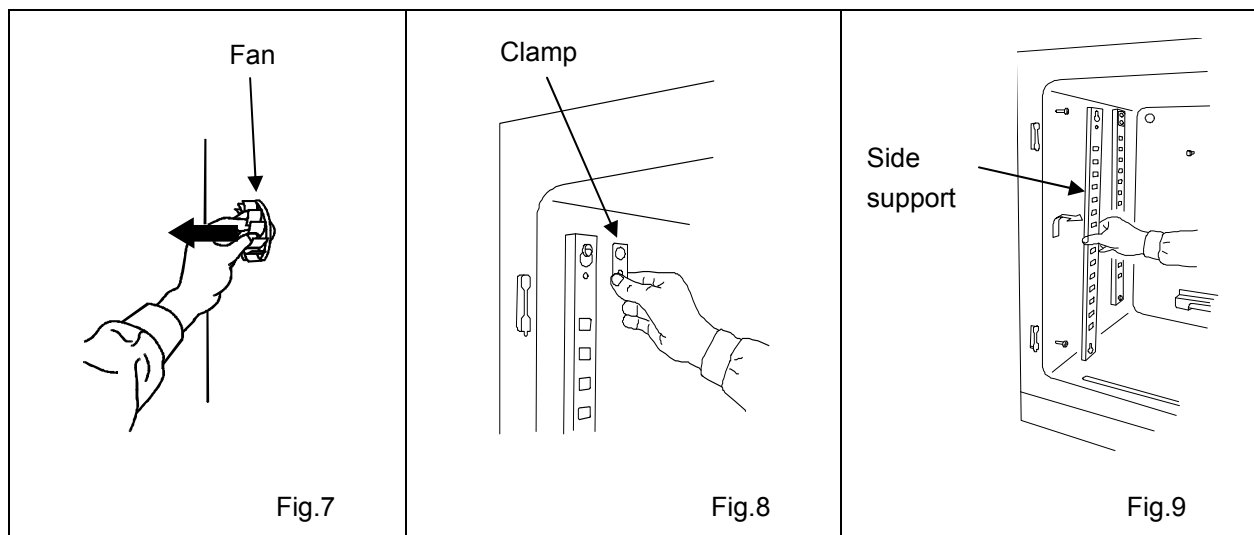

12. Clean all the attachments with a diluted neutral detergent, and then rinse them thoroughly with distilled water.

13. Wipe the trays, the inner attachments such as the fan, and the chamber sides with sterilizing alcohol. Be careful not to leave any residual alcohol.

14. Wipe the inside wall of the chamber with a gauze containing alcohol for sterilization and then wipe off with a dry gauze.

**15.** (MCO-18AC(UV) or when an optional UV system kit MCO-18UVS3 is installed)

Wipe the water level sensor with sterilizing alcohol. Be careful not to leave any residual alcohol. When cleaning the sensor, take care not to apply excessive force to the lead wires.

**16.** To reinstall all the attachments, perform the procedure in reverse order from step 11.

**17.** Fill the humidifying pan with sterile distilled water.

**Note:**

- When installing the fan, insert it securely on the motor shaft (See Fig.10). Lightly turn the fan manually to make sure that it does not strike the rear panel. Improper insertion may cause poor performance.
- As shown in Fig. 11, set the tray with only the front edge bent down. If the tray is set in the wrong direction, it may not be level and may become unstable.

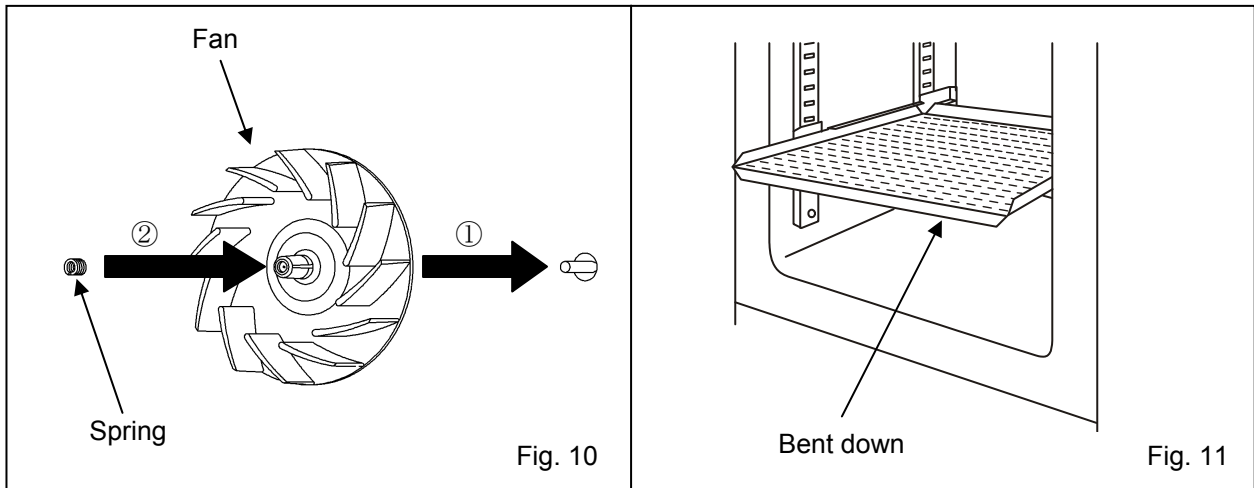

## Filling the humidifying pan

Use the following procedure to fill the humidifying pan or to replace the water.

1. (MCO-18AC(UV) or when an optional UV system kit MCO-18UVS3 is installed) Lift the humidifying pan cover. After that pull the humidifying pan forward. (See Fig. 1.)

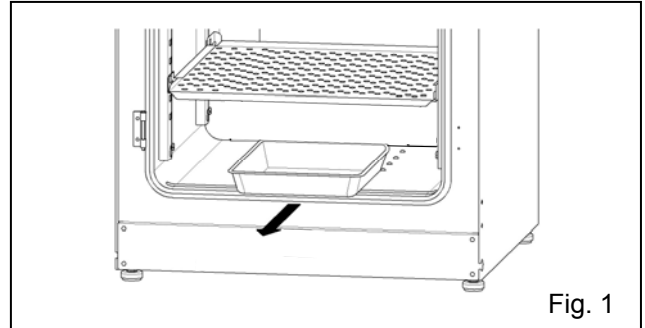

Fig. 1

2. Dispose of the remaining water in the humidifying pan and clean the humidifying pan with a neutral dishwashing detergent. Then rinse it thoroughly with distilled water and wipe it with sterilizing alcohol.

3. Wipe all moisture from the bottom of the chamber.

4. Return the humidifying pan to the chamber and add sterile distilled water (approx. 1.5 L, preheated to 37°C). (See Fig. 2.)

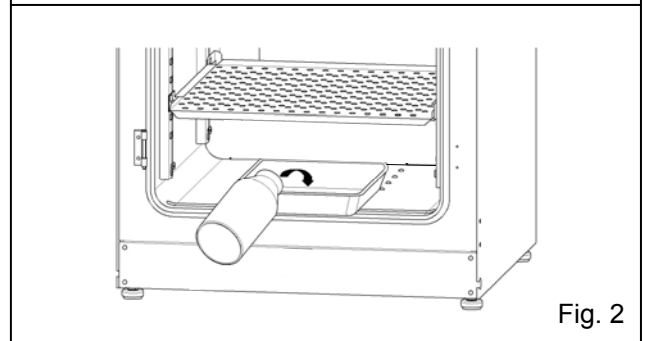

Fig. 2

**Note:**

Preheat to 37°C the water to be added to the humidifying pan. Adding low-temperature water will lower the temperature and humidity in the chamber.

5. Set the humidifying pan with the inner side flush against the back, and close the inner and outer doors.

(MCO-18AC(UV) or when an optional UV system kit MCO-18UVS3 is installed)

Set the humidifying pan with the inner side flush against the back, and replace the humidifying cover (Refer to page 24). Close the inner and outer doors, and confirm that water level alarm lamp (RH PAN) on the control panel is off.

**Note:**

(MCO-18AC(UV) or when an optional UV system kit MCO-18UVS3 is installed)

If the water level alarm lamp (RH PAN) blinks, use the above procedure to replenish the water.

### CAUTION

(MCO-18AC(UV) or when an optional UV system kit MCO-18UVS3 is installed)

When refilling the water in the humidifying pan, **always wipe off any dirt from the water level sensor with sterilizing alcohol**. While doing that, be careful not to apply excessive force to the sensor lead wire.



# CALIBRATION

## Temperature calibration

1. Press the calibration key (CAL) for approximately 5 seconds again to enter the temperature calibration input mode.
2. The left digit of the digital temperature indicator blinks, and the digital CO<sub>2</sub> density indicator goes out.
3. Set the present correct temperature with the digit shift key (▶▶) and numerical value shift key (▲), then press the enter key (ENT).
4. The incubator automatically reverts to the display mode.

[Example]

If the displayed chamber temperature is 37.0°C (set value) and the actual temperature is 36.8°C.

1. Press the calibration key (CAL) for about 5 seconds.
2. The “3” on the digital temperature indicator blinks, and the digital CO<sub>2</sub> density indicator goes out.
3. Adjust the set value to the actual value of 36.8°C with the digit shift key (▶▶) and numerical value shift key (▲), then press enter key (ENT).
4. The incubator automatically reverts to the display mode.

# CALIBRATION

## CO<sub>2</sub> calibration

### Span setting

Span setting should be done under stable condition of temperature, humidity, and CO<sub>2</sub> density.

1. Press the calibration key (CAL) once to enter the CO<sub>2</sub> calibration pre-conditioning mode.
2. Confirm blinking the decimal point in the digital CO<sub>2</sub> density indicator.
3. Open the outer door and remove the sample air outlet cap on the inner door.
4. Measure the CO<sub>2</sub> density in the chamber through the sample air outlet on the inner door.
5. Press the calibration key (CAL) for about 5 seconds again to enter the temperature calibration input mode.
6. The left digit on the digital temperature indicator blinks, and the digital CO<sub>2</sub> density indicator goes out.
7. Press the calibration key (CAL) once again to enter the CO<sub>2</sub> calibration input mode.
8. The left digit on the digital CO<sub>2</sub> density indicator blinks, and the temperature indicator goes out.
9. Set the present correct CO<sub>2</sub> density with the digit shift key (▶▶) and numerical value shift key (▲), then press the enter key (ENT).
10. Replace the sample air outlet cap.
11. The incubator automatically reverts to the display mode.

### Note:

This calibration is available when the setting of CO<sub>2</sub> density is 2% or more.

### [Example]

For an internal CO<sub>2</sub> density of 5.0% (setting) and a measured value of 4.5%.

1. Press the calibration key (CAL) once.
2. Press the calibration key (CAL) for about 5 seconds again.
3. The "3" on the digital temperature indicator blinks, and the digital CO<sub>2</sub> density indicator goes out.
4. Press the calibration key (CAL) once again.
5. The "0" on the digital CO<sub>2</sub> density indicator blinks, and the digital temperature indicator goes out. The left digit on the digital CO<sub>2</sub> density indicator blinks, and the temperature indicator goes out.
6. Set the present correct CO<sub>2</sub> density (4.5%) with the digit shift key (▶▶) and numerical value shift key (▲), then press the enter key (ENT).
7. The incubator automatically reverts to the display mode.

### Note:

It is important to accurately measure the temperature inside the incubator when calibrating the temperature. Particularly, the temperature gauge used must have an accuracy of JIS 0.5 Class or better. The temperature must be measured at several points.

The temperature setting must not change by more than  $\pm 1.0^{\circ}\text{C}$  during calibration. If these values are exceeded, an error buzzer will sound, the input data will be ignored, and the incubator will return to the display mode. If it is necessary to change the temperature by more than  $1.0^{\circ}\text{C}$ , perform calibration in several stages over a period of time.

# TROUBLESHOOTING

If the incubator does not seem to be working properly, check the following items before calling for service.

Malfunction	Check/Remedy
The incubator does not operate at all.	<ul style="list-style-type: none"> <li>The incubator is not plugged correctly into a power outlet.</li> <li>The circuit breaker at the power source is active or a power failure has occurred.</li> </ul>
The key operation is disable	<ul style="list-style-type: none"> <li>The key lock function is set in ON mode.</li> </ul>
If the alarm function and the buzzer operates	<p>[At the beginning of operation]</p> <ul style="list-style-type: none"> <li>The chamber temperature is not equal to the set value.</li> <li>The chamber CO<sub>2</sub> density is not equal to the set value.               <ol style="list-style-type: none"> <li>The secondary pressure of the pressure regulator is not equal to the set value (0.03MPaG, 0.3kgf/cm<sup>2</sup>G, 4.3psiG).</li> <li>The tube is not connected securely between the pressure regulator and the incubator.</li> </ol> </li> </ul> <p>[During operation]</p> <ul style="list-style-type: none"> <li>The upper limit alarm temperature is not set at least 1°C higher than the set chamber temperature.</li> <li>The set temperature value was changed, or the door was left open for a long period. Or a low temperature load was placed inside the incubator. In this case, if the incubator is left as it is, the alarm will eventually clear itself.</li> <li>The gas tube has slipped off or the gas leaks.</li> <li>The set value of the gas density was changed.</li> <li>The gas cylinder is empty. Check the primary pressure of the CO<sub>2</sub> cylinder once a week. (The primary pressure of less than 3.8MPaG (38kgf/cm<sup>2</sup>G) means a little gas in the cylinder. Replace the cylinder soon.)</li> </ul>
If the chamber temperature is not equal to the set temperature	<ul style="list-style-type: none"> <li>The ambient temperature must always be at least 5°C less than the set temperature.</li> <li>The outer door was closed while the inner door was left open.</li> </ul>
If the CO <sub>2</sub> gas density does not coincide with the set value	<ul style="list-style-type: none"> <li>The secondary pressure is not set to 0.03MPaG (0.3kgf/cm<sup>2</sup>G, 4.3psiG).</li> <li>The gas tube is clogged or chinked.</li> <li>The humidifying pan is not filled with sterile distilled water. (Always use sterile distilled water.)</li> </ul>
If the chamber humidity does not rise	<ul style="list-style-type: none"> <li>The humidifying pan is not filled with sterile distilled water. (Always use sterile distilled water.)</li> </ul>
If the CO <sub>2</sub> consumption is too much	<ul style="list-style-type: none"> <li>The door is opened frequently.</li> <li>There is any gas leakage at the connection or pin hole on the tube. It is recommended to replace the tube once a year.</li> <li>The gasket of the inner door is not completely sealed.</li> <li>The access port at the upper left corner is opened.</li> </ul>
If normal cultivation cannot be done and chamber gas density is suspect	<ul style="list-style-type: none"> <li>The environment around the incubator is not normal. The source of the contaminated gas is nearby.</li> <li>The incubator is installed in an enclosed space.</li> </ul>
If it takes much time to recover the CO <sub>2</sub> gas density	<ul style="list-style-type: none"> <li>HEPA filter is provided in the gas piping. If it takes much time to recover the gas density even though the gas pressure is normal, it may be that dust on the HEPA filter prevents the gas flow. Contact a Sanyo sales representative or agent.</li> </ul>
CO <sub>2</sub> gas is not being injected.	<ul style="list-style-type: none"> <li>The CO<sub>2</sub> control method for the incubator is the ON-OFF method. CO<sub>2</sub> gas is intermittently injected as the gas concentration in the chamber approaches the set value. Injections may be stopped for periods of approximately 15 seconds, but that is not an error.</li> </ul>

**Note:** If the problem still has not been solved after trying the above checks and countermeasures, or for any problems not covered here, contact a Sanyo sales representative or agent.

## DISPOSING OF THE CO<sub>2</sub> INCUBATOR

When disposing of the CO<sub>2</sub> incubator, contact a Sanyo sales representative or agent.



### **WARNING**

**The incubator must be dismantled and disposed of by qualified personnel only.** If the incubator is left where outsiders enter, it may result unexpected accident (for example, children to become locked inside).

Before disposing a CO<sub>2</sub> incubator with biohazardous danger, decontaminate the CO<sub>2</sub> incubator to the extent possible by the user.

**Note:**

**This symbol mark and recycle system are applied only to EU countries and not applied to the countries in the other area of the world.**

**Waste Electrical and Electronic Equipment (WEEE) Directive-2002/96/EC**

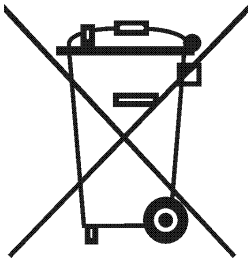

**(English)**

Your SANYO product is designed and manufactured with high quality materials and components which can be recycled and reused.

This symbol means that electrical and electronic equipment, at their end-of-life, should be disposed of separately from your household waste.

Please dispose of this equipment at your local community waste collection/recycling centre.

In the European Union there are separate collection systems for used electrical and electronic products.

Please help us to conserve the environment we live in!

**(German)**

Ihr SANYO Produkt wurde entworfen und hergestellt mit qualitativ hochwertigen Materialien und Komponenten, die recycelt und wiederverwendet werden können.

Dieses Symbol bedeutet, daß elektrische und elektronische Geräte am Ende ihrer Nutzungsdauer von Hausmüll getrennt entsorgt werden sollen.

Bitte entsorgen Sie dieses Gerät bei Ihrer örtlichen kommunalen Sammelstelle oder im Recycling Centre.

In der Europäischen Union gibt es unterschiedliche Sammelsysteme für Elektrik- und Elektronikgeräte.

Helfen Sie uns bitte, die Umwelt zu erhalten, in der wir leben!

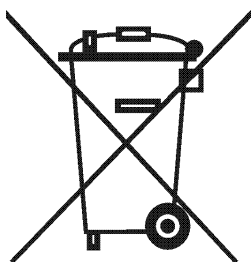

**(French)**

Votre produit Sanyo est conçu et fabriqué avec des matériels et des composants de qualité supérieure qui peuvent être recyclés et réutilisés.

Ce symbole signifie que les équipements électriques et électroniques en fin de vie doivent être éliminés séparément des ordures ménagères.

Nous vous prions donc de confier cet équipement à votre centre local de collecte/recyclage. Dans l'Union Européenne, il existe des systèmes sélectifs de collecte pour les produits électriques et électroniques usagés.

Aidez-nous à conserver l'environnement dans lequel nous vivons !

Les machines ou appareils électriques et électroniques contiennent fréquemment des matières qui, si elles sont traitées ou éliminées de manière inappropriée, peuvent s'avérer potentiellement dangereuses pour la santé humaine et pour l'environnement.

Cependant, ces matières sont nécessaires au bon fonctionnement de votre appareil ou de votre machine. Pour cette raison, il vous est demandé de ne pas vous débarrasser de votre appareil ou machine usagé avec vos ordures ménagères.

**(Spanish)**

Los productos SANYO están diseñados y fabricados con materiales y componentes de alta calidad, que pueden ser reciclados y reutilizados.

Este símbolo significa que el equipo eléctrico y electrónico, al final de su ciclo de vida, no se debe desechar con el resto de residuos domésticos.

Por favor, deposite su viejo "televisor" en el punto de recogida de residuos o contacte con su administración local.

En la Unión Europea existen sistemas de recogida específicos para residuos de aparatos eléctricos y electrónicos.

Por favor, ayúdenos a conservar el medio ambiente!

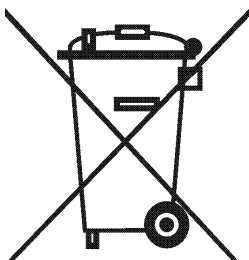

**(Portuguese)**

O seu produto SANYO foi concebido e produzido com materiais e componentes de alta qualidade que podem ser reciclados e reutilizados.

Este símbolo significa que o equipamento eléctrico e electrónico no final da sua vida útil deverá ser descartado separadamente do seu lixo doméstico.

Por favor, entregue este equipamento no seu ponto local de recolha/reciclagem.

Na União Europeia existem sistemas de recolha separados para produtos eléctricos e electrónicos usados.

Por favor, ajude-nos a conservar o ambiente em que vivemos!

**(Italian)**

Il vostro prodotto SANYO è stato costruito da materiali e componenti di alta qualità, che sono riutilizzabili o riciclabili.

Prodotti elettrici ed elettronici portando questo simbolo alla fine dell'uso devono essere smaltiti separatamente dai rifiuti casalinghi.

Vi preghiamo di smaltire questo apparecchio al deposito comunale.

Nell'Unione Europea esistono sistemi di raccolta differenziata per prodotti elettrici ed elettronici.

Aiutateci a conservare l'ambiente in cui viviamo!

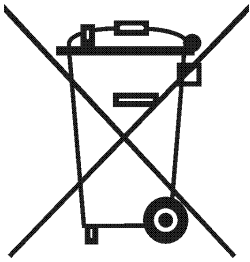

**(Dutch)**

Sanyo producten zijn ontwikkeld en gefabriceerd uit eerste kwaliteit materialen, de onderdelen kunnen worden gerecycled en weer worden gebruikt.

Het symbool betekent dat de elektrische en elektronische onderdelen wanneer deze vernietigd gaan worden, dit separaat gebeurt van het normale huisafval.

Zorg ervoor dat het verwijderen van de apparatuur bij de lokaal erkende instanties gaat gebeuren. In de Europese Unie wordt de gebruikte elektrische en elektronische apparatuur bij de daarvoor wettelijke instanties aangeboden.

Alstublieft help allen mee om het milieu te beschermen.

**(Swedish)**

Din SANYO produkt är designad och tillverkad av material och komponenter med hög kvalitet som kan återvinnas och återanvändas.

Denna symbol betyder att elektriska och elektroniska produkter, efter slutanvändande, skall sorteras och lämnas separat från Ditt hushållsavfall.

Vänligen, lämna denna produkt hos Din lokala mottagningstation för avfall/återvinningsstation.

Inom den Europeiska Unionen finns det separata återvinningssystem för begagnade elektriska och elektroniska produkter.

Vänligen, hjälp oss att bevara miljön vi lever i!



# AUTOMATIC CO<sub>2</sub> CYLINDER CHANGEOVER

An automatic CO<sub>2</sub> cylinder changeover system (MCO-21GC) is available as an optional accessory. This system switches the gas supply line when one CO<sub>2</sub> gas cylinder is empty.

**Note:** The installation of the MCO-21GC must be performed only by qualified service personnel.

Install the MCO-21GC and then perform the following procedure

1. Connect the CO<sub>2</sub> gas pipes to connecting ports for CO<sub>2</sub> gas pipes A and B. Connecting ports for CO<sub>2</sub> gas pipes are located on the left back of the incubator. (Refer to page 8).

**Note:** Only port A can be used when the MCO-21GC is not installed. There will be 2 ports, ports A and B, after the MCO-21GC is installed.

2. Connect a CO<sub>2</sub> gas cylinder equipped with a gas pressure regulator to each gas pipe. Refer to page 14 for information on connecting the CO<sub>2</sub> gas cylinders. ("Gas cylinder A" is the CO<sub>2</sub> gas cylinder connected to the CO<sub>2</sub> gas pipe connected to port A, and "gas cylinder B" is the CO<sub>2</sub> gas cylinder connected to the CO<sub>2</sub> gas pipe connected to port B.)

3. Open the valve of both gas cylinders.

4. Check that the CO<sub>2</sub> gas supply line indicator on the control panel is lit by pressing the CO<sub>2</sub> gas supply line switching key.

5. Select a CO<sub>2</sub> gas supply line (A or B).

6. The MCO-21GC detects that there is no more CO<sub>2</sub> gas in a cylinder when the CO<sub>2</sub> density in the chamber does not increase for a while even after opening the CO<sub>2</sub> gas valve in the incubator. It switches the gas supply line when it detects that there is no more gas. At that time, the following indications of switching the gas cylinder are provided.

Digital temperature indicator	Buzzer	CO <sub>2</sub> gas supply line indicator	
		Empty line	The other line
E01 is displayed alternately with the temperature on the digital temperature indicator.	Intermittent tone	Blinks	Lights

● To silence the buzzer, press the alarm buzzer stop key (BUZZER). The alarm condition is cleared and normal operation continues.

7. When gas cylinder A is switched to B, remove gas cylinder A and replace it with new one.

**Note:** Be careful when handling the empty CO<sub>2</sub> gas cylinder. Some gas may still be left in the cylinder.

8. When gas cylinder B becomes empty, the line is switched to gas cylinder A again.

The MCO-21GC detects that there is no more CO<sub>2</sub> gas in a cylinder when the CO<sub>2</sub> density in the chamber does not increase for a while even after opening the CO<sub>2</sub> gas valve in the incubator. The supply line may also be switched for other reasons even though there is gas left in the cylinder: blocking or restricting of gas tube, reduction of CO<sub>2</sub> gas pressure, or improper opening of CO<sub>2</sub> gas cylinder. Always check the gas quantity in the cylinder before disconnecting it.

# STACKING INCUBATORS

Use the following procedure to stack incubators. This work is potentially dangerous, so contact a Sanyo sales representative or agent.

## CAUTION

- **Select a floor that is strong enough to support the stacked incubators.**
- **Never stack three or more incubators.** Doing so is dangerous.

1. Take out two stacking plates A, two stacking plates B, four protective stickers, and four screws from accessory bag.

### **Note:**

When stacking two incubators, **use two stacking plates (A and B) for each one.** Only one pair of stacking plates is provided per incubator, so take out the stacking plates (A and B) from both incubators. Similarly only 2 protective stickers are provided per incubator

2. Unplug both of the incubators that are to be stacked.

3. Remove the caps at the two places in the front of the top surface of the incubator that is to be on the bottom, and attach the protective stickers to the four corners on the top surface of the incubator that is to be on the bottom. (See Fig. A. on the page 41)

4. Secure stacking plates A with the screws that are provided.

5. Remove the front panel (4 screws) from the incubator that is to be on the top.

6. Place the upper incubator on top of the lower one, being careful not to pinch your fingers.

7. Make the lower incubator level by adjusting the leveling feet, and then level the upper incubator in the same way.

8. Secure stacking plates A on the top surface of lower incubator to the upper one with the accessory screws.

9. Remove from the back of the lower incubator the two hooks (4 screws) and remove from the upper incubator the 2 screws on the lower rear panel.

10. Use the 6 screws that were removed in step 9 to secure stacking plates B to the rear panels of the upper and lower incubators.

11. Replace the front panel (4 screws) to the upper incubator.

12. Use the hooks on the back of the upper incubator to prevent the incubators from falling over.

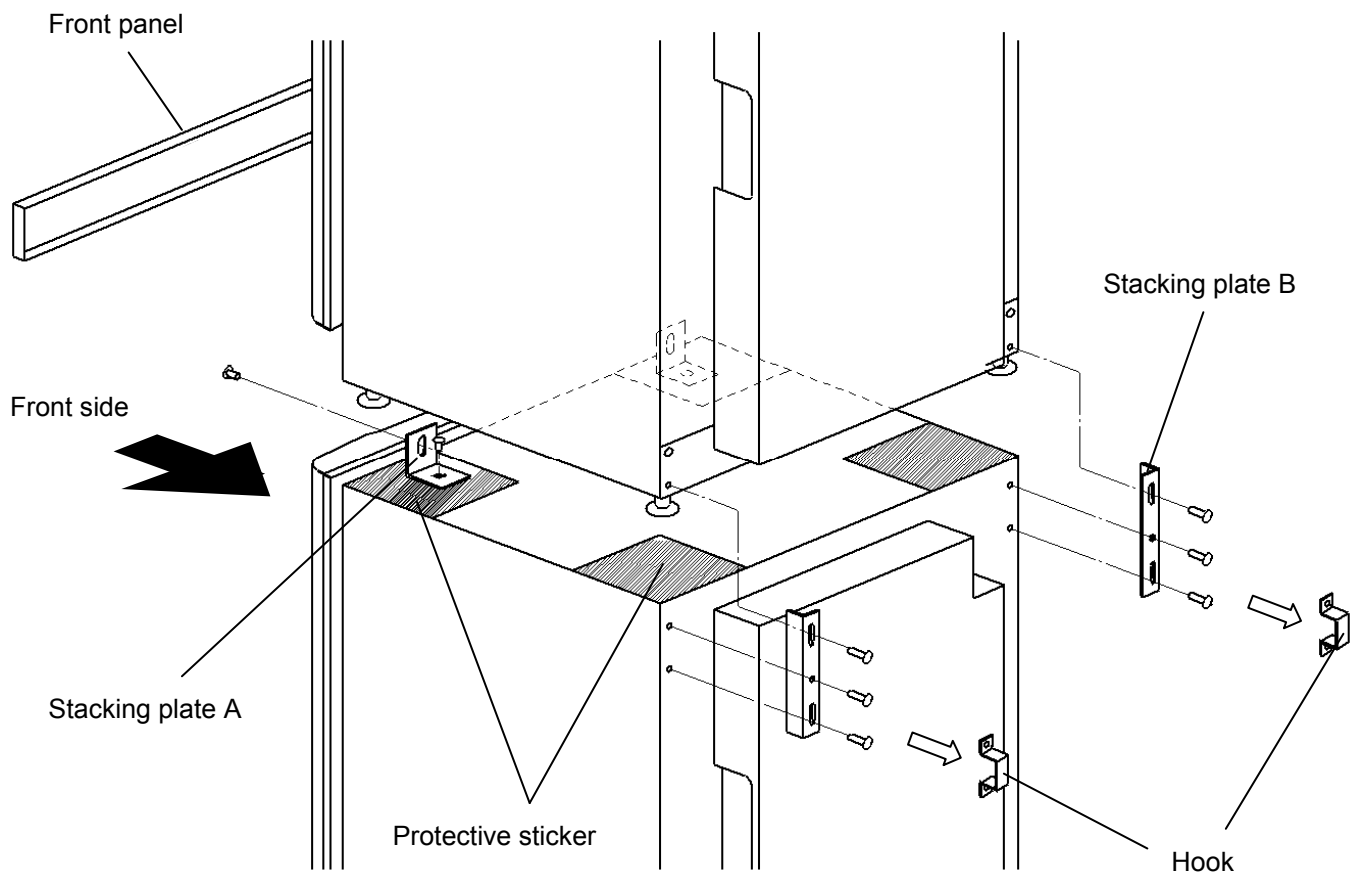

Fig.A

# SPECIFICATIONS

Name	CO <sub>2</sub> incubator	
Model	MCO-18AC	MCO-18AC(UV)
External dimensions	W620 x D710 x H900 (mm)	
Internal dimensions	W490 x D523x H665 (mm)	
Interior volume	170 L	
Exterior	Painted steel	
Interior	Stainless steel containing copper	
Outer door	Painted steel	
Inner door	Tempered glass	
Tray	3 trays made of stainless steel containing copper W450 x D450 x H12 (mm), Maximum load; 7 kg/tray	
Access port	Inner diameter; 30 mm, On the back side	
Insulation	Rigid polyurethane foamed-in place	
Heating system	DHA system (heater jacket + air jacket system)	
Heater	282 W	
Humidifying system	Natural evaporation with humidifying pan	
Temperature controller	PID control system	
Temperature display	Digital display	
CO <sub>2</sub> controller	ON-OFF control system/TC sensor	
CO <sub>2</sub> density display	Digital display	
Air circulation	Fan assisted	
Air filter	0.3 μm, Efficiency; 99.97% or more	
UV lamp	----	4W X 1 (ozone-free emission)
Water level sensor	----	Optical type
Alarm	----	UV lamp failure alarm Low humidifying water alarm
		Automatic set temperature alarm, Automatic set CO <sub>2</sub> density alarm Upper limit temperature alarm, various gas/sensor/heater alarms
Remote alarm contact	Allowable contact capacity: DC 30 V, 2 A	
CO <sub>2</sub> inlet connection	4 to 6 mm diameter tube can be connected	
CO <sub>2</sub> inlet pressure	0.03MPaG (0.3kgf/cm <sup>2</sup> G, 4.3psiG)	
Accessories	3 trays, 3 sets of tray support, 1 gas tube, 1 humidifying pan, Stacking plate A and B, 2 protective stickers, 2 tube bands	
Weight	92 kg	93 kg
Optional accessory	UV system kit (MCO-18UVS3)	Standard equipment
	UV replacement kit (MCO-20UV), 4-20mA Interface(MCO-420MA, USA only) Gas pressure regulator (MCO-100L) Extra tray (MCO-47ST) including 2 tray supports, Half tray (MCO-25ST) Automatic CO <sub>2</sub> cylinder changeover system (MCO-21GC), Roller base (MCO-18RB) RS232C/RS485 Interface (MTR-480), Ethernet (LAN) Interface (MTR-L03) SANYO Data acquisition software (MTR-5000)	

**Note:** Design or specifications will be subject to change without notice.

# PERFORMANCE

Temperature control range	Ambient temperature +5°C to 50°C (ambient temperature; 5°C to 35°C)		
Temperature distribution	± 0.25°C (ambient temperature; 25°C, setting; 37°C, CO <sub>2</sub> 5%, no load)		
Temperature variation	± 0.1°C (ambient temperature; 25°C, setting; 37°C, CO <sub>2</sub> 5%, no load)		
CO <sub>2</sub> control range	0 to 20%		
CO <sub>2</sub> variation	± 0.15% (ambient temperature; 25°C, setting; 37°C, CO <sub>2</sub> 5%, no load)		
Chamber humidity	95 ± 5%RH		
Heat emission	Max. 1116 kJ/h		
Applicable environment condition	Temperature: 5°C to 35°C, Humidity: equal or less than 80% R.H. (The designed performance may not be obtained when the ambient temperature is equal or less than 15°C)		
Noise level	24 dB (A scale)		
Power consumption	Max. 300 W	Max. 310 W	
Rated voltage, frequency	110 to 120 V, 60 Hz	220 V, 60 Hz	220 to 240 V, 50 Hz
Amperage	Max. 2.6 A	Max. 1.4 A	Max. 1.4 A

**Note:** The unit with CE mark complies with EC directives.  
It is based on our measuring method.

**⚠ CAUTION**

**Please fill in this form before servicing.  
Hand over this form to the service engineer to keep for his and your safety.**

## Safety check sheet

1. Incubator contents :
- |                                |                              |                             |
|--------------------------------|------------------------------|-----------------------------|
| Risk of infection:             | <input type="checkbox"/> Yes | <input type="checkbox"/> No |
| Risk of toxicity:              | <input type="checkbox"/> Yes | <input type="checkbox"/> No |
| Risk from radioactive sources: | <input type="checkbox"/> Yes | <input type="checkbox"/> No |

(List all potentially hazardous materials that have been stored in this unit.)

Notes :

2. Contamination of the unit
- |                  |                              |                             |
|------------------|------------------------------|-----------------------------|
| Unit interior    | <input type="checkbox"/> Yes | <input type="checkbox"/> No |
| No contamination | <input type="checkbox"/> Yes | <input type="checkbox"/> No |
| Decontaminated   | <input type="checkbox"/> Yes | <input type="checkbox"/> No |
| Contaminated     | <input type="checkbox"/> Yes | <input type="checkbox"/> No |
- Others:

3. Instructions for safe repair/maintenance of the unit
- |                                     |                              |                             |
|-------------------------------------|------------------------------|-----------------------------|
| a) The unit is safe to work on      | <input type="checkbox"/> Yes | <input type="checkbox"/> No |
| b) There is some danger (see below) | <input type="checkbox"/> Yes | <input type="checkbox"/> No |
- Procedure to be adhered to in order to reduce safety risk indicated in b) below.

Date :

Signature :

Address, Division :

Telephone :

Product name : CO <sub>2</sub> incubator	Model : MCO-18AC MCO-18AC(UV)	Serial number :	Date of Installation :
---	-------------------------------------	-----------------	------------------------

Please decontaminate the unit yourself before calling the service engineer.