

High Resolution and Accurate Colors for Documentation

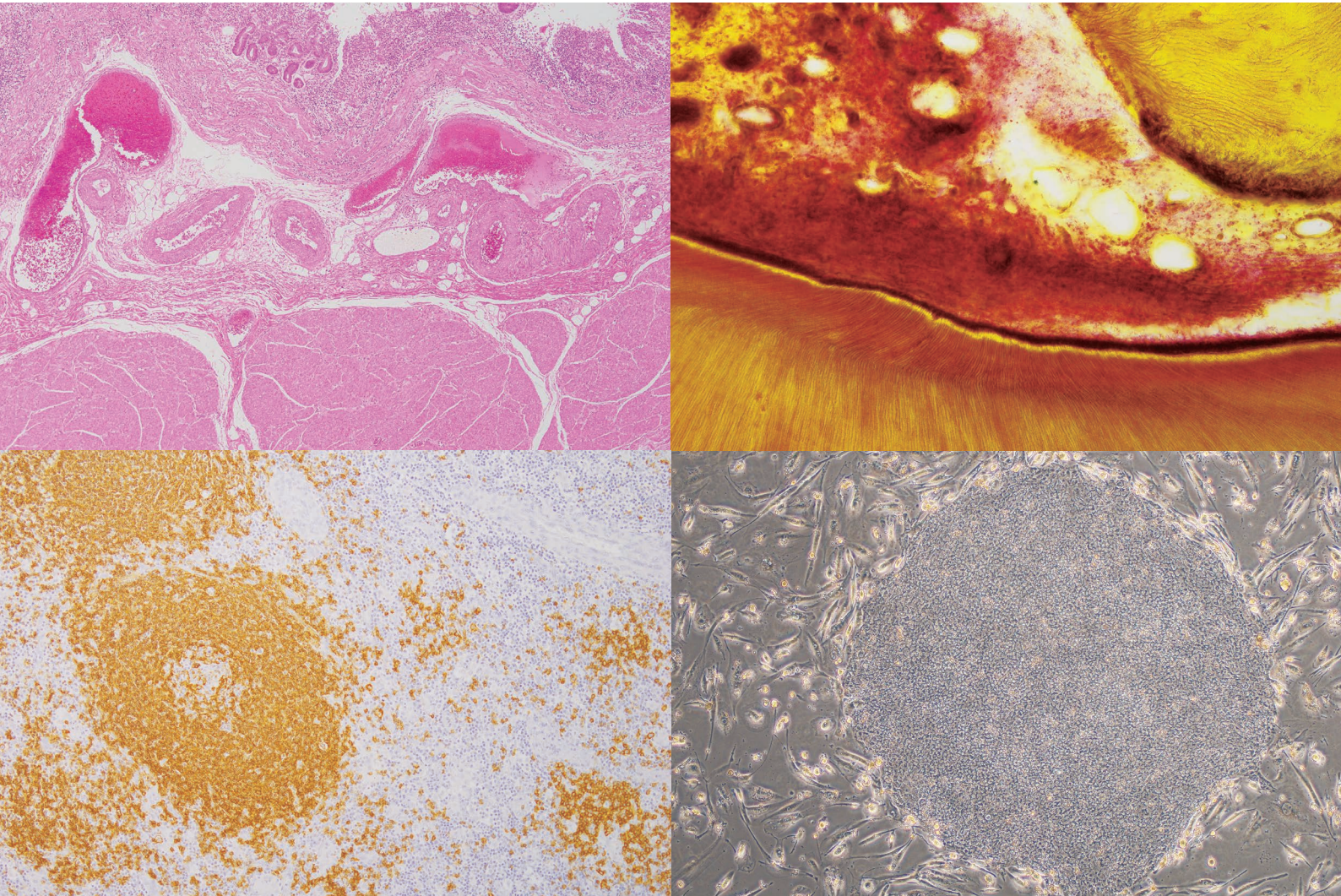

High Image Quality and Reliable Color Reproduction with
5.05-Megapixel High-Resolution CCD.
Streamline Documentation Procedures with High Frame-Rate Live Capture.

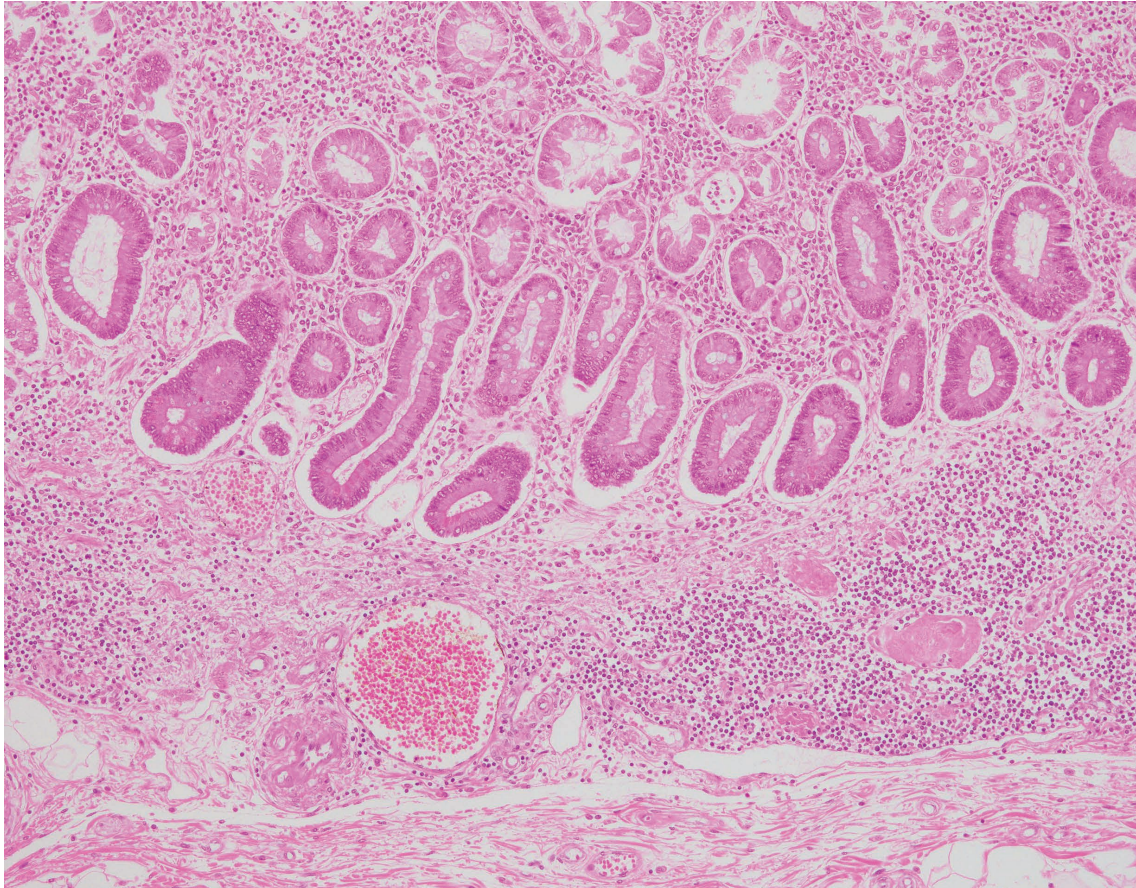

High Quality Image Design Optimized for Documentation

◎ 5.05-Megapixel High-Definition CCD

Equipped with an exceptional 5.05-megapixel CCD, the DP27 digital camera captures images at up to 2448 x 1920 pixel resolution. Large areas captured at low magnification offer exceptionally vivid clarity, even when enlarged several times.

◎ Excellent Color Reproduction

Precise reproduction of fine structures and subtle color differences allows areas of interests on the monitor to be identified with an accuracy equivalent to observation through microscope.

◎ 15 Frames Per Second Under High Resolution

DP27 provides a fast and smooth live image at the 5.05 megapixel resolution, for quick and effortless panning and focusing. Even when working at Full HD resolution, a comfortably fast live image at 22 frames per second is available. As the non-compressed image is able to reproduce images with absolutely no degradation in quality, operators make simple focusing and framing.

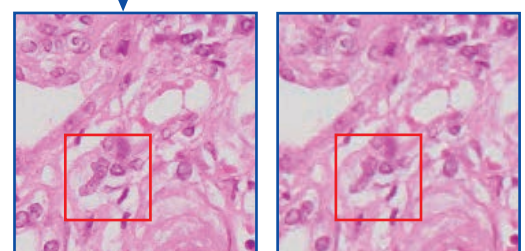
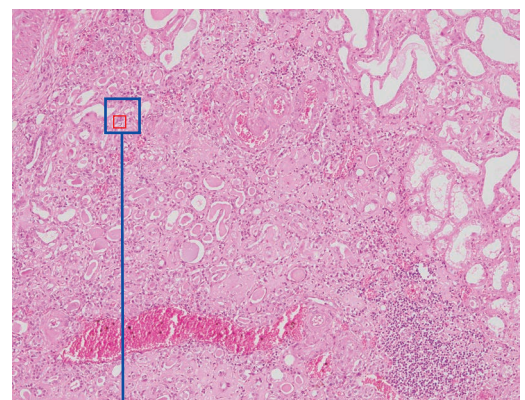

5M Detailed structure can be observed.

2M



◎ Three Color Modes

Three color modes are provided, enabling the operator to tailor the image to suit the requirements of different applications. By selecting one of the three preset modes, optimum images can be acquired under various samples and observations without having to change all the settings each time.

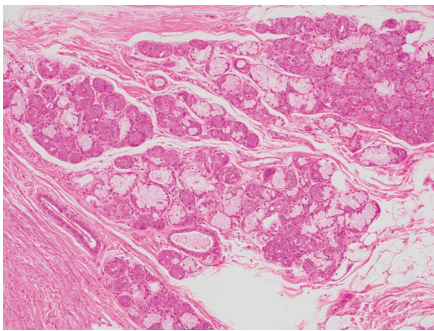

High fidelity mode

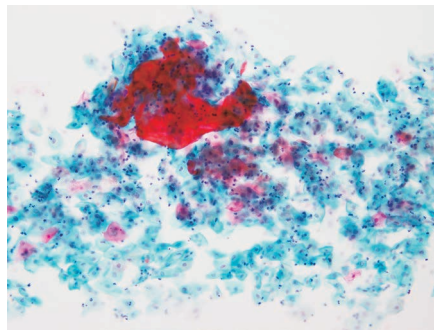

Normal mode

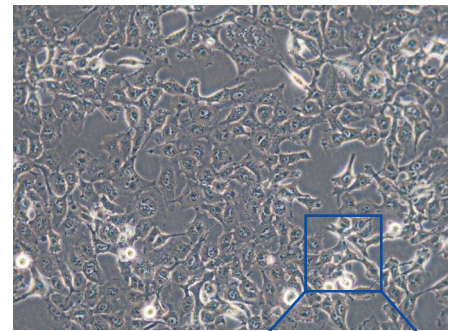

Cell culture mode

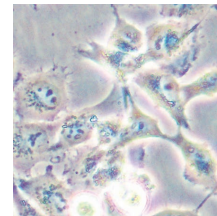

Conventional mode

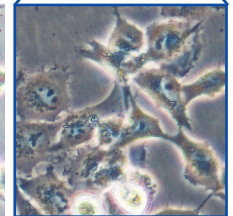

Cell culture mode:
Halation is reduced to allow clear observation of cell shapes.

- **High fidelity mode** : Reliable color reproduction equivalent to microscope observation.
- **Normal mode** : Enhanced color facilitates acquisition of even pale stained specimens.
- **Cell culture mode** : Dedicated to phase contrast and DIC observations.

Superior Functionality and Enhanced Scalability Give You More Flexibility and Operational Convenience

◎ cellSens Imaging Software

(Not for Clinical Diagnostic Use.)

Adjust white balance, switch to live display and capture images, all at the touch of a button. cellSens offers an array of image processing capabilities, including a versatile shading function that enables real-time correction for variations in peripheral field illumination intensity. In addition, exposure settings, magnifications, and other parameters are saved with acquired images for easy storage and retrieval.

The innovative cellSens software offers a wide array of useful and easy-to-use functions. Split-screen display, for example, provides simultaneous viewing of multiple images, or a live image and the most recently captured image. Pictures taken at adjacent locations can also be stitched together to create a single image using the Multi-Image Array functionality. cellSens software has the capability to store user comments with captured images, which can be referred to as necessary or searched using the cellSens Database.

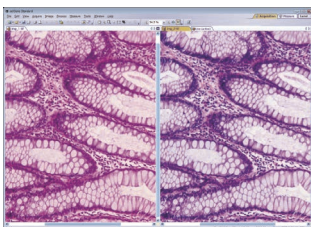

Split-screen Display

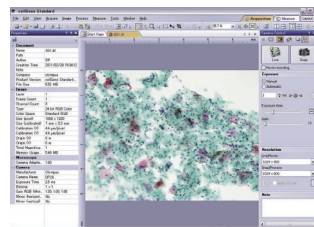

File management

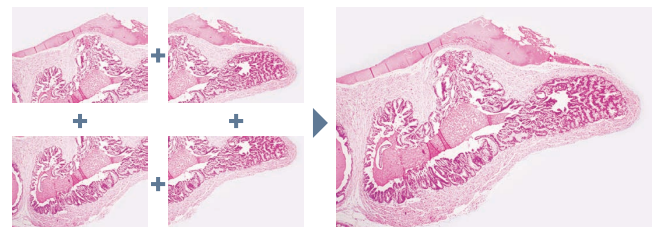

Automatic & Manual Image Stitching

◎ Easy USB 3.0 Connection

The DP27 is compliant with the USB 3.0 standard for quick connection to compatible computers and fast transfer of image data.

Flexible Design with Stand-Alone Operation Capability

◎ Simple, Space-Saving Stand-Alone Connectivity

While PC-connected operation provides optimal functionality and scalability, the DP27 can also function effectively in a stand-alone configuration, which features simple operation and easy control from mouse, keyboard or touchscreen monitor.

DP27 PC configuration system diagram

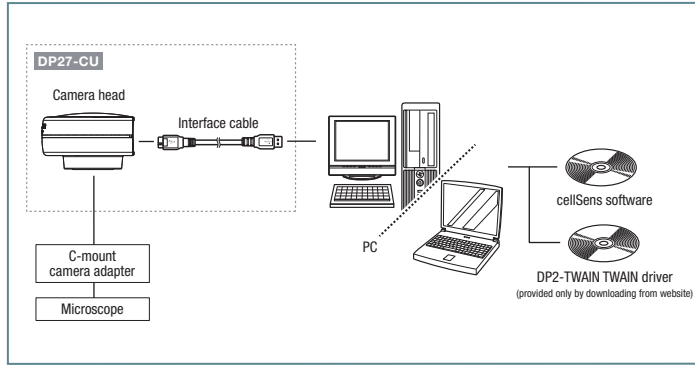

DP27 Specification

| | | |
|------------------|--|---|
| Type | Single chip color CCD camera | |
| Imaging sensor | Size | 2/3 inch color CCD |
| | Effective pixels | 5.05 megapixels (total: 5.24 megapixels) |
| | Scanning method | Progressive scanning |
| | Color filter | RGB primary color on-chip filters |
| | Recording area | 8.4(H) × 6.62(V) mm, diagonal length 10.73 mm |
| | Maximum recorded pixels | 4.7 megapixels (2448 × 1920) |
| Mount | C-mount | |
| Sensitivity | Equivalent to ISO 100/200/400 | |
| Metering Area | Full image / 30% / 1% | |
| Exposure control | Auto/Manual | |
| | AE lock (enabled when Auto Exposure is selected) | Exposure compensation: Area -2EV to +1EV, +side:1/6EV step, - side:1/3EV step (enables when Auto Exposure is selected.) |
| Exposure time | Auto: 1/20,000s to 2s | |
| | Manual: 1/20,000s to 8s | |
| Camera I/F | USB3.0 Micro-B | |
| Dimension | Camera Head | 77 (W) × 69.5 (D) × 42.5 (H) mm |
| | Control Unit | 180 (W) × 200 (D) × 47 (H) mm |

DP27 stand-alone configuration system diagram

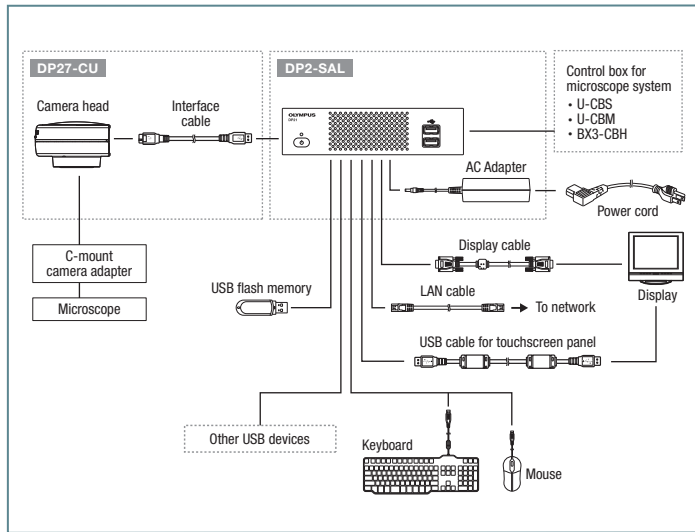

| | PC connection | Stand-alone |
|---------------------------------|--|--|
| Image size | 2448 × 1920 | 2448 × 1920 |
| | 1920 × 1080 (Full HD) | 1920 × 1080 (Full HD) |
| | 1224 × 960 | 1224 × 960 |
| | | 1224 × 960 (AVI File) ^{*1} |
| Live image display (frame rate) | 15fps (2448 × 1920) | 15fps (2448 × 1920) |
| | 22fps (1920 × 1080) | 22fps (1920 × 1080) |
| | 30fps (1224 × 960) | 30fps (1224 × 960) |
| | | |
| Compatible image display | | 1920 × 1200 WUXGA |
| | | 1920 × 1080 Full HD |
| | | 1680 × 1050 WSXGA+ |
| | | 1600 × 1200 UXGA |
| | | 1280 × 1024 SXGA |
| | | 1280 × 960 QVGA |
| | | 1280 × 854 WXGA |
| | | 1280 × 768 WXGA |
| | | 1024 × 768 XGA |
| | | 1024 × 600 WSVGA |
| | 800 × 480 WVGA | |
| Storage media | — | USB flash memory, USB-HDD |
| Controller interface | USB 3.0 (+5V / 900mA power output) | Camera I/F: USB 3.0 Type-A |
| | | Display output: DVI-I (Digital/Analog RGB) |
| | | I/F: USB 2.0 × 4, USB 3.0 × 1 |
| | | Wired LAN: 100Base-TX/10Base-T |
| | | Serial port: RS-232C D-Sub 9-pin |
| | | Audio: Mic in, Line out |
| Scale display | According to cellSens ^{®2} specifications | Scale view & burn in can be selected |
| | | Available microscope total magnification: 0.01× to 9999.99× Up to 28 total magnifications can be memorized |
| Measuring functions | According to cellSens ^{®2} specifications | Distance of 2 Points, 3 Points Circle, Distance between 2 Circle Centers, 3 Points Angle, 4 Points Angle, Perpendiculars, Polygon Area, Boundary Length, Distance of Parallel Lines, XY Distance, Count, Poly Line, and Cross Line |
| | | |

^{*1} With system limitations, skipping of frames may occur in the acquired movie depending on the specimen.

^{*2} cellSens software is not for clinical diagnostic use.

Image data courtesy of:
"Human iPS Cell colony"
Isao Asaka
Center for iPS Cell Research and Application, Kyoto University
(lower right, cover page)

- OLYMPUS CORPORATION is ISO14001 certified.
- OLYMPUS CORPORATION is ISO9001 certified.
- All company and product names are registered trademarks and/or trademarks of their respective owners.
- Images on the PC monitors are simulated.
- Specifications and appearances are subject to change without any notice or obligation on the part of the manufacturer.



Wolflabs

Wolf Laboratories Limited

www.wolflabs.co.uk

Tel: 01759 301142

Fax: 01759 301143

sales@wolflabs.co.uk



Use the above details to contact us if this literature doesn't answer all your questions.

Pricing on any accessories shown can be found by keying the part number into the search box on our website.

The specifications listed in this brochure are subject to change by the manufacturer and therefore cannot be guaranteed to be correct. If there are aspects of the specification that must be guaranteed, please provide these to our sales team so that details can be confirmed.

