

# Guide to Operations

***innova™ 2000/2050***

## Digital Platform Shaker

MANUAL NO: M1190-0050

Revision P

January 19, 2004

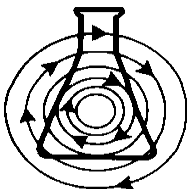

---

**NEW BRUNSWICK SCIENTIFIC CO., INC.**

BOX 4005 • 44 TALMADGE ROAD • EDISON, NJ 08818-4005

Telephone: 1-732-287-1200 • 1-800-631-5417

Fax: 732-287-4222 • Telex: 4753012 NBSCO

Internet: <http://www.nbsc.com> • E-mail: [bioinfo@nbsc.com](mailto:bioinfo@nbsc.com)

---



---

## INTERNATIONAL OFFICES:

### **BELGIUM**

New Brunswick Scientific NV-SA  
Stationsstraat 180/4  
3110 Rotselaar  
België/Belgique  
Tel: 32 (0)16 56 28 31  
Fax: 32 (0)16 57 27 53  
E-mail: sales@nbsnv-sa.be

### **CHINA**

New Brunswick Scientific Co., Inc.  
Room 1501, Xiangjiang Building, No. 18  
Lane 1265, Zhongshan Road (W)  
Shanghai 200051, P.R. China  
Tel: 86 21 3223 0203  
Fax: 86 21 6278 7182  
E-mail: nbschc@online.sh.cn

### **FRANCE**

New Brunswick Scientific SARL  
3, rue des Deux-Boules  
75001 Paris  
France  
Tel: 33 (0)1 4026 2246  
Fax: 33 (0)1 4026 5423  
E-mail: sales@nbssarl.fr

### **GERMANY**

New Brunswick Scientific GmbH  
In Der Au 14  
D-72622 Nürtingen  
Deutschland  
Tel: 49 (0)7022 932490  
Fax: 49 (0)7022 32486  
E-mail: sales@nbsgmbh.de

### **THE NETHERLANDS**

New Brunswick Scientific BV  
Kerkenbos 1101, 6546 BC Nijmegen  
P.O Box 6826, 6503 GH Nijmegen  
Nederland  
Tel: 31 (0)24 3717 600  
Fax: 31 (0)24 3717 640  
E-mail: sales@nbsbv.nl

### **UNITED KINGDOM**

New Brunswick Scientific (UK) Ltd.  
17 Alban Park  
St. Albans, Herts. AL4 0JJ  
United Kingdom  
Tel: 44 (0)1727 853855 or 0800 581331  
Fax: 44 (0)1727 835666  
E-mail: bioinfo@nbsuk.co.uk  
Web: www.nbsuk.co.uk

**THIS PAGE INTENTIONALLY BLANK**

**CAUTION!**

This equipment *must* be operated as described in this manual. If operational guidelines are not followed, equipment damage and personal injury *can* occur. Please read the entire User's Guide before attempting to use this unit.

Do not use this equipment in a hazardous atmosphere or with hazardous materials for which the equipment was not designed.

New Brunswick Scientific Co., Inc. (NBS) is not responsible for any damage to this equipment that may result from the use of an accessory not manufactured by NBS.

**THIS PAGE INTENTIONALLY BLANK**

## Copyright Notice

New Brunswick Scientific Company, Inc.  
Box 4005 44 Talmadge Road  
Edison, New Jersey 08818-4005

© Copyright 2004 New Brunswick Scientific Co., Inc.

All Rights Reserved.

Reproduction, adaptation, or translation without prior written permission from

New Brunswick Scientific is prohibited.

## Disclaimer Notice

New Brunswick Scientific Co., Inc. reserves the right to change information in this document without notice. Updates to information in this document reflect our commitment to continuing product development and improvement.

## Manual Conventions



### NOTE:

**Notes contain essential information that deserves special attention.**



### CAUTION!

**Caution messages appear before procedures which, if caution is not observed, could result in damage to the equipment.**

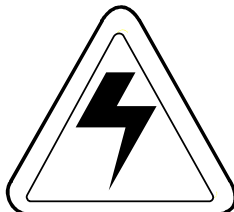

### WARNING!

**Warning messages alert you to specific procedures or practices which, if not followed correctly, could result in serious personal injury.**

### Bold

**Text in bold face type emphasizes key words or phrases.**

**THIS PAGE INTENTIONALLY BLANK**





**THIS PAGE INTENTIONALLY BLANK**

## TABLE OF CONTENTS

<b>1</b>	<b>INTRODUCTION.....</b>	<b>13</b>
<b>2</b>	<b>OVERVIEW .....</b>	<b>15</b>
2.1	UNIVERSAL POWER MODULE.....	16
2.2	CONTROL PANEL .....	16
2.2.1	<i>LED Display.....</i>	<i>17</i>
2.2.2	<i>User Interface Keys.....</i>	<i>17</i>
2.2.3	<i>Status Indicators.....</i>	<i>18</i>
2.2.4	<i>Function Indicators.....</i>	<i>18</i>
2.3	PLATFORM ASSEMBLIES.....	19
2.4	HEAVY DUTY CONSTRUCTION .....	19
2.4.1	<i>Bearings .....</i>	<i>19</i>
2.4.2	<i>Motor.....</i>	<i>19</i>
2.4.3	<i>Triple Eccentric Drive.....</i>	<i>19</i>
2.5	ELECTRONIC BOARDS.....	20
2.6	AVAILABLE OPTIONS .....	21
2.6.1	<i>Temperature Monitor Option.....</i>	<i>21</i>
2.6.2	<i>Capacity Upgrade Option.....</i>	<i>21</i>
<b>3</b>	<b>UNPACKING &amp; INSTALLATION .....</b>	<b>23</b>
3.1	UNPACKING.....	23
3.2	VERIFYING VOLTAGE CONFIGURATION.....	23
<b>4</b>	<b>INSTALLATION .....</b>	<b>25</b>
4.1	LOCATION .....	25
4.2	ELECTRICAL CONNECTIONS .....	26
4.3	INSTALLING THE PLATFORM.....	26
4.4	INSTALLING OPTIONAL FLASK CLAMPS .....	26
<b>5</b>	<b>OPERATION.....</b>	<b>29</b>
5.1	POWERING UP .....	29
5.2	CONTINUOUS (UNLIMITED) RUN .....	29
5.3	CHECKING SETPOINTS .....	29
5.4	TIMED FUNCTIONS .....	30
5.5	ALARM FUNCTIONS.....	30
5.6	TOTAL RUNNING TIME .....	31
5.7	TEMPERATURE MONITOR OPTION .....	31
5.8	CLEANING & MAINTENANCE .....	32
<b>6</b>	<b>SERVICE.....</b>	<b>33</b>
6.1	FUSE REPLACEMENT .....	33
6.2	CHANGING VOLTAGES .....	34
6.3	FUSING ARRANGEMENT .....	35

---

6.3.1	<i>Single to Double Fuse Conversion</i> .....	35
6.4	REMOVING THE SUBPLATFORM .....	37
6.5	REPLACING THE DRIVE BELT .....	38
6.5.1	<i>Adjusting Belt Tension</i> .....	38
6.6	REINSTALLING THE SUBPLATFORM .....	39
6.7	REPLACING THE MOTOR ASSEMBLY .....	39
6.8	MAINT INDICATOR .....	40
6.9	TEMPERATURE MONITOR OPTION .....	41
6.9.1	<i>ESD Precautions</i> .....	41
6.9.2	<i>Installing the Temperature Monitor Option</i> .....	42
6.10	CAPACITY UPGRADE OPTION .....	43
6.10.1	<i>Installing the Capacity Upgrade Option</i> .....	44
<b>7</b>	<b>PARTS &amp; ACCESSORIES</b> .....	<b>45</b>
7.1	INNOVA 2000 PLATFORMS .....	45
7.2	INNOVA 2050 PLATFORMS .....	45
7.3	ACCESSORY FLASK CLAMPS .....	46
7.4	SERVICE PARTS .....	46
<b>8</b>	<b>SPECIFICATIONS</b> .....	<b>47</b>
<b>9</b>	<b>DRAWINGS</b> .....	<b>51</b>
9.1	LIST OF DRAWINGS .....	52
9.2	LIST OF TABLES.....	52
<b>10</b>	<b>INDEX</b> .....	<b>53</b>

# 1 INTRODUCTION

The Innova 2000/2050 Digital Platform Shaker will provide you with reliable and maintenance-free operation that is characteristic of all NBS shakers.

The Innova 2000/2050 incorporates a variety of state-of-the-art components and features to permit the precision operation necessary for your exacting scientific experiments.

**We recommend that you completely familiarize yourself with this manual prior to operating the Innova 2000/2050.**

**THIS PAGE IS INTENTIONALLY BLANK**

## 2 OVERVIEW

The Innova 2000/2050 is a portable benchtop shaker utilizing a triple eccentric counter-balanced drive to provide horizontal plane rotary motion in a 3/4" (19 mm) circular orbit. A Proportional/Integral (PI) microprocessor controller with instantaneous digital feedback controls the speed over a range of 25-500 RPM.

The shaker may be operated either continuously or in a timed mode via a programmable timer for shaking periods of 0.1 hour to 99.9 hours. A Temperature Monitoring option is available for the measurement, display and documentation of sample temperature.

The Innova 2000/2050 is equipped with audible and visible alarms that are activated when one of these alarm conditions exists:

- The end of a timed run
- Deviations of shaking speed or temperature outside of tolerance limits

A wide variety of platforms can be used with the Innova 2000/2050. Dedicated platforms are available for a variety of flask sizes. Universal platforms, utility trays and utility carriers are also available (*see Section 7 for accessories*).

**Figure 1a: Front View**

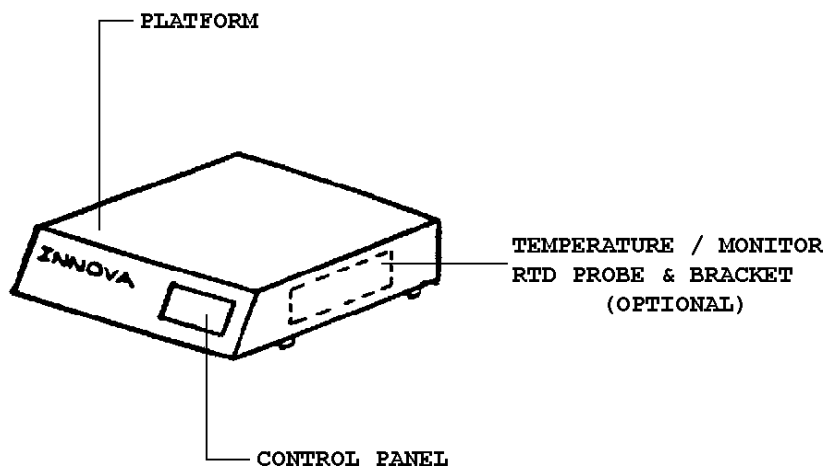

**NOTE:**

**Unless otherwise indicated, all drawings represent both Innova 2000 and Innova 2050 models.**

Figure 1b: Rear View

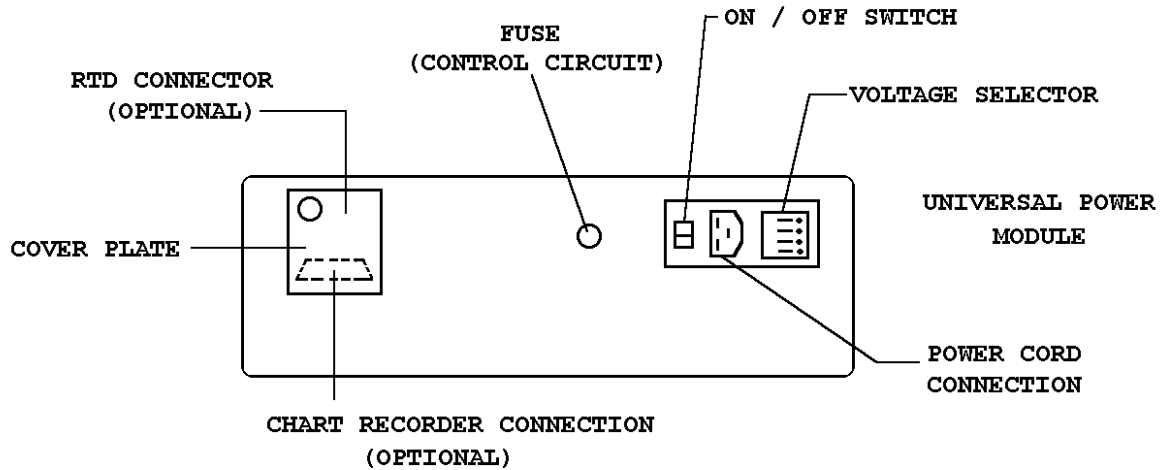

## 2.1 Universal Power Module

The power module contains a voltage card and fuse holder which are used to select the appropriate voltage and fusing. This universal power entry system adapts to worldwide power requirements. Voltage and fusing have been set prior to shipment. Innova shakers are available in 100V, 120V, 220V and 240V, and accommodates both 50 and 60 Hz frequencies.



### **WARNING!**

It is critical to check the voltage before plugging the unit in to a power source. Confirm that the voltage setting is correct by checking the Voltage Selector in the Universal Power Module (see Figure 1b) and the CAUTION label located over the power switch and power cord connection.

If necessary, consult Section 6.2 to change the voltage selection.

## 2.2 Control Panel

The control panel (see Figure 2), located on the front of the instrument, serves as the operator interface. The keypad has four keys marked **START/STOP**, ▲, ▼ and **SELECT**. A three-digit LED display provides numeric values as well as some letter codes. There are four **function indicator** and four **status indicator** lights on the control panel as well.

A general description of the display, user interface keys and indicators follows. For operation of the control panel, see Section 5, *Operation*.



**Figure 2: Control Panel**

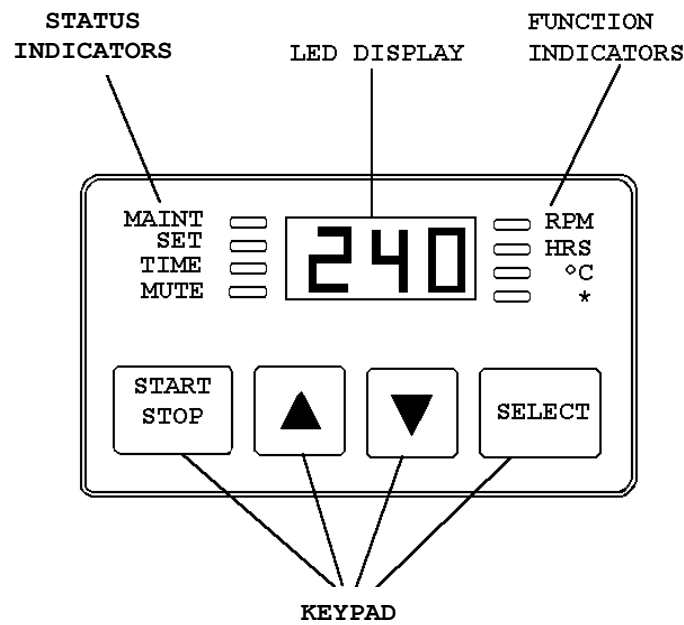

### 2.2.1 LED Display

The Innova control panel has a three-digit LED display. During normal shaker operation, the display will indicate:

- Shaker status (on/off)
- Shaking speed
- Setpoints
- Hours remaining (timed run)
- Measured temperature (when Temperature Monitor option is installed)

### 2.2.2 User Interface Keys

There are four user interface keys on the control panel. Table 1 below explains their functions:

**Table 1: User Interface Keys**

Key	Function
START/STOP	This key is used to start or stop the shaking motion. It will also activate or stop the timer when a timed run is desired.
▲	These keys are used to adjust the setpoint of a displayed parameter up or down. They also allow the user to enter the SET mode for setpoint changes.
▼	
SELECT	This key is used to change the displayed parameter. <b>NOTE:</b> Temperature (°C) cannot be selected unless the temperature/remote monitoring option is installed.

### 2.2.3 Status Indicators

Table 2 below explains the function of the four status indicator lights, which are located to the left of the control panel display.

**Table 2: Status Indicators**

Status Light	Function
MAINT	Remains lit after 10,000 hours of use. Accumulated running time is internally monitored and may be displayed as a guideline.
SET	Indicates that the shaker is in the SET mode: setpoints are being displayed and can be altered.
TIME	Indicates that the timer is in operation. Innova shakers can be programmed to run for a preset time from 0.1 hour to 99.9 hours. The timer can be disengaged without stopping an ongoing run.
MUTE	Indicates the status of the audible alarm: when the MUTE indicator is illuminated, the audible alarm device is disabled.

### 2.2.4 Function Indicators

As show in Table 3 below, the four function indicator lights (located to the right of the control panel display) show the current parameter being displayed:

**Table 3: Function Indicators**

Status Light	Function
RPM	Revolutions Per Minute shaking speed
HRS	Hours: run time remaining
°C	Temperature in degrees Celsius (activated only if the optional Temperature Monitor is installed)
*	This function is not active in the Innova 2000 or 2050

---

## 2.3 **Platform Assemblies**

Neither the Innova 2000 nor the 2050 can be used without a platform. One must be purchased and installed on your shaker prior to operation (see Section 4.3 for installation instructions).

The Innova 2000 can be used with a wide range of NBS 11" x 13" (28 cm x 33 cm) platforms, which will accept a variety of clamps for flasks, test tubes, etc. For details, see the listing in Section 7.1.

The Innova 2050 can accommodate an even wider range of NBS 12" x 16" (30.5 cm x 40.6 cm) platforms, which will accept a variety of clamps for flasks, test tubes, etc. For details, see the listing in Section 7.2.

## 2.4 **Heavy Duty Construction**

### 2.4.1 **Bearings**

Innova shakers employ sealed lubricated ball bearings of the highest quality. Sealed bearings minimize the generation of airborne particulates that could be disadvantageous in clean rooms or controlled environment areas. These bearings require **no maintenance**.

### 2.4.2 **Motor**

Innova 2000 and 2050 shakers use a three-phase brushless ball bearing DC motor. This low profile motor provides high torque along with quiet, efficient operation and low maintenance. The motor has a rating of 1/20 horsepower.

### 2.4.3 **Triple Eccentric Drive**

The patented triple eccentric drive used in all Innova shakers employs the same proven technology that has driven New Brunswick Scientific's shakers for over 30 years.

The drive mechanism utilizes a counterweight system to stabilize the rotary motion produced during operation. When the workload moves in one direction, opposing forces are generated to stabilize the shaker. This action will help eliminate the problem of "walking" which may occur with less precisely balanced instruments. Vibration is minimized and the life of the unit is extended.

**Figure 3: Counterbalanced Drive Mechanism**

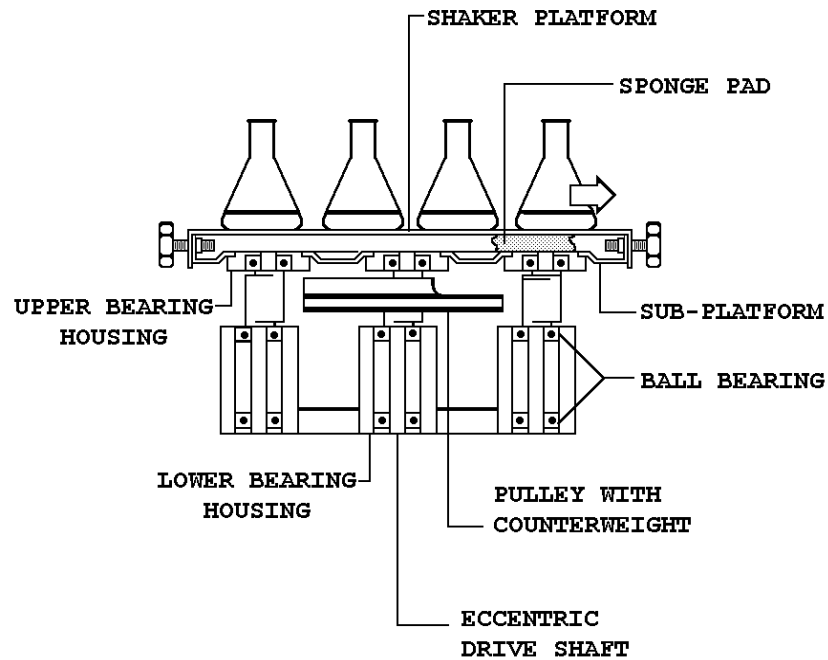

## 2.5 *Electronic Boards*

The main control board for Innova shakers has the following functions:

- Non-volatile memory for storage of key parameters during power interruption;
- Speed sensing, electronic commutation, and power control for the brushless DC drive motor;
- Maintains an elapsed running time clock;
- Contains firmware for shaker control as well as recognition of an expansion connector for option modules;
- Provides an operator interface via displays, audible alarm, and connection to the keypad module (keypad buttons and display graphics).

The optional Temperature Monitor module is designed to “piggyback” onto the main board via an expansion connector. It has the following functions:

- Control of analog power supplies;
- Signal conditioning of RTD sensor readings;
- Provide remote monitoring capabilities by supplying analog outputs for speed and temperature that are compatible with chart recorders and analog data acquisition systems.

## 2.6 Available Options

Section 6, *Service*, provides detailed instructions for the field installation of these options by an authorized service technician.

### 2.6.1 Temperature Monitor Option

A Temperature Monitor Option is available (NBS part number M1190-9909). The ambient temperature or the temperature of the liquid in any vessel can be measured using the RTD electronics-based measuring device supplied with this option.

The LED will display the measured temperatures in 0.1°C increments. This option also allows the connection of a chart recorder so that shaking speed and temperature can be documented. The analog output for shaking speed is 0-5V: 1V per 100 RPM. For temperature, the output is 0-5V (0.05V per °C).

The output can also be connected to a data logging computer with an analog data acquisition card.

### 2.6.2 Capacity Upgrade Option

It is possible to significantly increase the capacity of an Innova 2000 shaker with an available capacity upgrade package (NBS part number M1190-9910). This option will simply and easily convert an Innova 2000 to an Innova 2050.

This package consists of a 12" x 16" (30.5 cm x 40.6 cm) subplatform to replace the 11" x 13" (25cm x 33 cm) subplatform, and the appropriate counterweight and hardware.



#### **NOTE:**

**Large capacity Innova 2050 platforms must be used with the increased capacity configuration. See Section 7.2, *Innova 2050 Platforms*, for a listing of available platforms.**

**THIS PAGE IS INTENTIONALLY BLANK**

## 3 UNPACKING & INSTALLATION

### 3.1 *Unpacking*

When you unpack the unit, inspect it carefully for any apparent damage that may have occurred during transit. Report any damage to the carrier and to New Brunswick Scientific's Service Department.

Verify against the packing list that you have received everything; report any missing item(s) to your NBS representative.

Do not discard the crate or packing material.

### 3.2 *Verifying Voltage Configuration*

Determine the voltage of your unit by checking the voltage selector and the label on the rear of the unit, and confirm that the correct electrical service package is included with the unit by comparing the part number on the package to Table 4 below (*see also Section 6, Service*).

**Table 4: Voltage Configuration Chart**

Innova 2000/2050 Voltage	Electrical Service Package
100V or 120V, 50/60 Hz	M1190-0350
220V or 240V, 50/60 Hz single fuse	M1190-0360
220V or 240V, 50/60 Hz double fuse	M1190-0370



#### **NOTE:**

The operation of Innova shakers requires a platform, a separate accessory:

- 11" x 13" (28cm x 33 cm) platforms used on the NBS model G2 Shaker can also be used on the Innova 2000.
- If you have an Innova 2050 or a 2000 with the capacity upgrade package, you will need a 12" x 16" (30.5 cm x 40.6 cm) platform. See Section 7, *Parts & Accessories*.

**THIS PAGE IS INTENTIONALLY BLANK**



## 4 INSTALLATION

### 4.1 Location

It is essential that the shaker be situated in a area where there is sufficient space for the shaker and platform to clear walls and potential obstructions during operation.

Consult Table 5 and Figures 4a and 4b below to provide the necessary space for your shaker in operation before you install it. The dimensions provided include a platform, but do not include glassware.

**Table 5: Operating Space Requirements**

Model	Dimensions			Space Requirements	
	Width	Depth	Height	Width	Depth
Innova 2000	14 inches 35.5 cm	14¼ inches 36 cm	5⅜ inches 13.9 cm	17 inches 43 cm	17 inches 43 cm
Innova 2050	17 inches 43 cm	14¼ inches 36 cm	5⅜ inches 13.9 cm	20 inches 50 cm	20 inches 50 cm

**Figure 4a: Innova 2000 Operating Space**

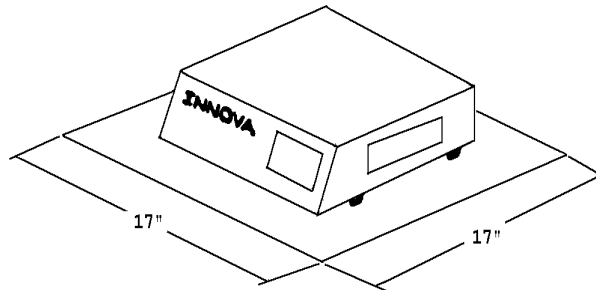

**Figure 4b: Innova 2050 Operating Space**

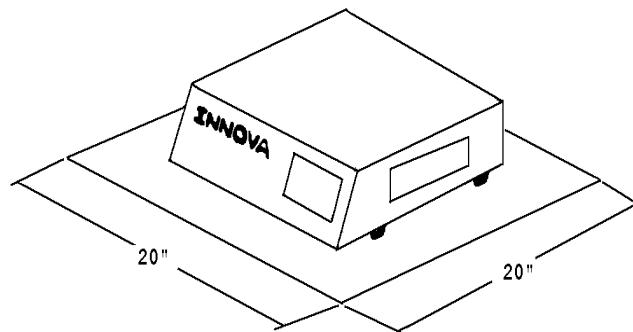

## 4.2 *Electrical Connections*



### **CAUTION!**

**Before you plug your shaker into the electrical supply, to avoid damage to the unit, be sure to:**

- **Follow steps 1-3 below, and**
- **Use only a grounded electrical outlet.**

1. Check the voltage selector in the Universal Power Module at the rear of the unit (*see Figure 2*) to ensure that it is set to the appropriate voltage. If it is not, change the voltage selection as explained in Section 6.2.
2. Remove the CAUTION label from the universal power module.
3. Set the power switch on the back of the unit to the OFF position.

**ONLY THEN:**

4. Connect the power cord to the universal power module and to a grounded electrical outlet.

## 4.3 *Installing the Platform*

A platform (purchased separately) must be installed on the unit prior to use.







1. Place the platform on the subplatform. Make sure that all four slots are seated over the four knob screw-shafts. Be sure to use a platform of the proper size for your particular shaker.
2. Tighten the four knobs to secure the platform.

## 4.4 *Installing Optional Flask Clamps*







If you have purchased flask clamps for use with a universal platform, they will require installation. Clamps are installed by securing the base of the clamp to the platform with the correct type and number of screws (refer to Tables 6 & 7 below). All clamps are shipped complete with hardware.

Because NBS flask clamps are used on a variety of shaker platforms, flat head screws of different lengths and thread pitch are used to secure the clamp, according to the platform. The following tables will help you identify the proper screw for your shaker application:

**Table 6: 10 to 500 ml Clamp Hardware Application Chart**

<i>Description</i>	<i>Part Number</i>	<i>Qty.</i>	<i>Application</i>
 10-24 x 5/8 (15.87 mm) flat Phillips (+) head screw	S2116-3101	1	3/4" (19.05 mm) thick wood platform 
 10-24 x 5/16 (7.9 mm) flat Phillips (+) head screw	S2116-3051	1	5/16" (7.9 mm) thick aluminum, phenolic and stainless steel platforms. 
 10-32 x 5/16 (7.9 mm) flat slotted (-) head screw	S2117-3050	1	all stainless steel platforms 

**Table 7: 1- to 6-Liter Clamp Hardware Application Chart**

<i>Description</i>	<i>Part Number</i>	<i>Qty.</i>	<i>Application</i>
 10-24 x 5/8 (15.87 mm) flat Phillips (+) head screw	S2116-3101	5	3/4" (19.05 mm) thick wood platform 
 10-24 x 5/16 (7.9 mm) flat Phillips (+) head screw	S2116-3051	5	5/16" (7.9 mm) thick aluminum, phenolic and stainless steel platforms. 
 10-32 x 5/16 (7.9 mm) flat slotted (-) head screw	S2117-3050	5	all stainless steel platforms 



**NOTE:** 2800 ml Fernbach Flask Clamp are covered by Table 7.

Clamps for 2- to 6-liter flasks are shipped with an additional girdle to keep the flasks in place (see *Figure 5 below*). To install 2- to 6-liter clamps:

1. Place the clamp on the platform, secure it in place with the hardware provided (making sure they are the correct type of screws by referring to Tables 6 & 7 above).
2. Place the loose girdle around the upper portion of clamp body so that it is held in place by the legs of the clamp.
3. Insert the flask into the clamp.

**Figure 5: 2- to 6-Liter Clamp Installation**

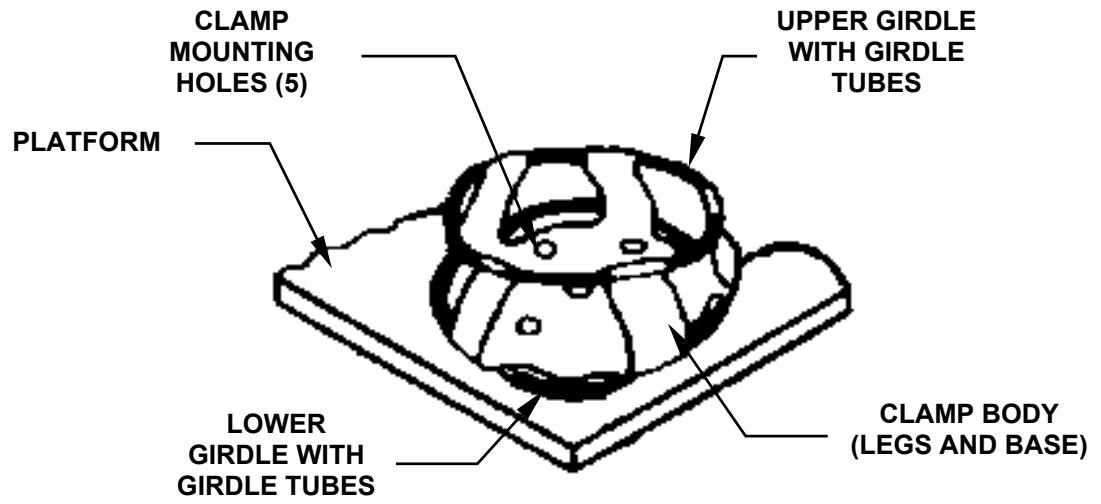

**NOTE:**

Figure 5 is also valid for 2800 ml Fernbach Flask Clamps.

## 5 OPERATION

### 5.1 *Powering Up*

To initially start the instrument, turn the **ON/OFF** switch on the back of shaker to the **ON** position.

If the shaker is running, the LED display will track the speed as it accelerates to the last entered setpoint.

The shaking action may be stopped or started by pressing the **START/STOP** key on the control panel.

### 5.2 *Continuous (Unlimited) Run*

To run the shaker continuously:

1. If the LED displays OFF, press the **START/STOP** key.
2. Press **SELECT** until the **RPM** indicator illuminates.
3. Press either the ▲ or ▼ key to enter **SET** mode (**SET** indicator will light).
4. Set the speed by pressing the ▲ or ▼ key until the desired setpoint is displayed. Holding the ▲ or ▼ key down will cause the setting to change more rapidly.

The setpoint may be changed during a run without stopping the shaker by following steps 2-4. During speed changes, the alarm may sound until the speed returns to within 5 RPM of the setpoint.

### 5.3 *Checking Setpoints*

To check any setpoint:

1. Press the **SELECT** key until the desired indicator is lit.
2. Press either ▲ or ▼ to enter the **SET** mode and display the current setpoint.



#### **CAUTION!**

Holding the ▲ or ▼ key for more than 0.5 second will cause the speed setpoint to change. Should this occur, resetting will be necessary.

## 5.4 *Timed Functions*

The shaker may be programmed to automatically stop after a preset time period of 0.1 hour - 99.9 hours. There must be power to the shaker in order to set the timer; a timed run can be initiated, however, while the unit is either shaking or stopped.

### **To set the timer:**

1. Press the **SELECT** key until the **HRS** indicator is illuminated.
2. Press either **▲** or **▼** to enter the **SET** mode and set the desired run time, between 0.1 and 99.9 hours.
3. While **SET** indicator is lit, press the **START/STOP** key to program the time (and start the run). The **TIME** indicator will light and remain on for the duration of the run. At the end of the timed run, the display will read **OFF**, the **TIME** indicator will flash and the audible alarm will beep.

**To stop the alarm**, press the **SELECT** key and change to any other function.

### **To cancel the timer WITHOUT stopping the shaker:**

1. Press the **SELECT** key until the **HRS** indicator is illuminated.
2. Press either **▲** or **▼** to enter the **SET** mode and set the desired run time, between 0.1 and 99.9 hours.
3. Immediately press the **START/STOP** key. The **TIME** indicator will go out and the display will read **OFF**.



### **NOTE:**

**The shaker may be started or stopped by pressing the START/STOP key. When starting, the unit will automatically return to the last function and speed settings. The audible alarm will beep until the speed is within 5 RPM of the setpoint. The alarm will not sound, however, while the shaker is reaching the set speed after power-up.**

## 5.5 *Alarm Functions*

Innova shakers have an audible alarm which is activated at predetermined times.

### **To deactivate the alarm:**

1. Press **SELECT** until the **HRS** indicator is illuminated.
2. **Simultaneously** press the **▲** and **▼** keys. The **SET** and **MAINT** indicators will flash.

3. While the **SET** and **MAINT** indicators are flashing, press the **START/STOP** key. The **MUTE** indicator will light to advise that the audible alarm has been deactivated.

To reactivate the alarm, repeat steps 1-3. The **MUTE** indicator will go out to advise that the alarm has been reactivated.

## 5.6 *Total Running Time*

To track hours of usage, the Innova 2000/2050 control modules total the time the shaker has been **ON**. To display the accumulated running time:

1. Select **HRS** using the **SELECT** key.
2. **Simultaneously** press the **▲** and **▼** keys.
3. The **SET** and **MAINT** indicators will flash and the accumulated running time will be displayed in hundreds of hours (i.e., “02” equals 200 hours; “102” equals 10,200 hours). This display will continue for 10 seconds and then default to the previous mode readout.

After 10,000 hours of operation, the **MAINT** indicator will light. Preventive maintenance is recommended at this point. The NBS service technician will turn the indicator light off.



### **NOTE:**

**Any alteration of the internal clock by unauthorized personnel will void the warranty.**

## 5.7 *Temperature Monitor Option*

This option consists of an internal electrical interface, an RTD temperature probe and an analog output for chart recorder or computer. When this option is installed, either the ambient temperature or the temperature of any vessel on the shaker platform can be measured with the probe.



### **NOTE:**

**The °C indicator functions only when the Temperature Monitor option is installed.**

**To measure ambient temperature:**

1. With the probe housed in its holder, press the **SELECT** key until the °C indicator illuminates.
2. Ambient temperature will be displayed.

**To measure temperature within a vessel:**

1. Remove the probe from its holder and insert it into the vessel to be monitored.
2. Use the **SELECT** key to indicate °C.

Since the Temperature Monitor option does not provide temperature control, any attempt to enter a temperature setpoint results in **Err** (“Error”) being displayed.

## **5.8      *Cleaning & Maintenance***

The unit may be cleaned using a damp cloth or any standard, household or laboratory cleaner to wipe down its outer surfaces. Do not use abrasive or corrosive compounds to clean this instrument, as they may damage the unit and void the warranty.

The Innova 2000/2050 requires no routine maintenance by the user. The **MAINT** indicator light goes on at the end of 10,000 hours of use. At that time contact your local NBS Service Engineer or call the NBS Service Department. This periodic maintenance will keep your unit in premium condition.



## 6 SERVICE

The following section describes basic troubleshooting and service procedures. It also provides instructions to install optional features.



### **WARNING!**

**Before performing any service, turn off the power, using the ON/OFF switch on the rear panel, and disconnect the power cord.**

### 6.1 Fuse Replacement

To replace fuses (without changing the fusing arrangement), referring to Figure 6):

1. Always disconnect the unit from the power source first.
2. Using a small screwdriver, remove the cover/fuse block located on the rear panel.
3. Remove the old fuse, insert a new one of the same type, and replace the cover/fuse block into the power module.

**Figure 6: Power Module/Fuse Block**

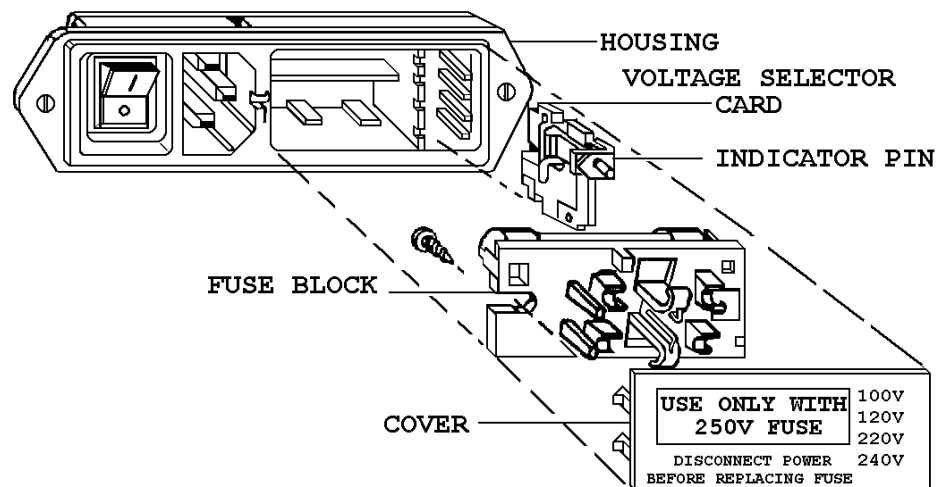

## 6.2 Changing Voltages

Prior to shipment, Innova shakers are set at the appropriate line voltage with the proper fuses. The power module, however, is a universal power-entry system that can be reset to adapt to worldwide power requirements.

If it is necessary to reset the voltage on your shaker, use the following procedure:

1. Turn the unit off and disconnect it from the power source.
2. Open the cover of the power module, using a small blade screwdriver or the like, and remove the cover/fuse block assembly (*see Figure 6*).
3. Remove the voltage selector card from the housing by pulling the indicator pin straight out (*see Figure 6*).
4. Along each edge of the voltage selector card, the voltage options are printed in large numbers: 100, 120, 220, 240. Place the card in front of you with the desired voltage printed at the bottom (*see Figure 7*).
5. With the card in this position, orient the indicator pin to point up. The voltage has now been changed and the card can be reinserted.

**Figure 7: Voltage Selector Card Orientation**

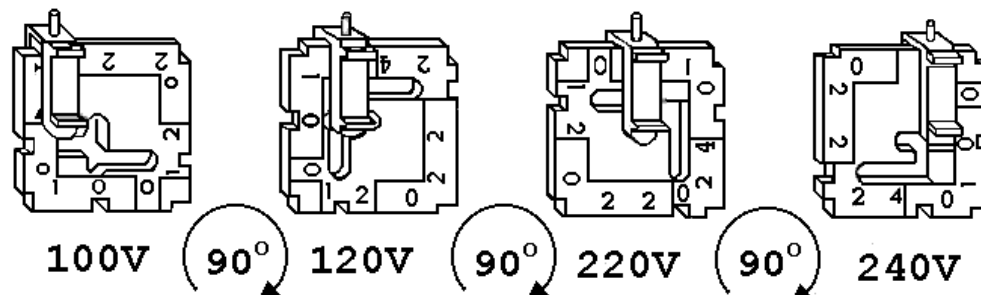

6. Hold the voltage selector card so that the indicator pin is facing you and the alignment arrow points left (*see Figure 8*).
7. Replace the card in the voltage selector slot at the righthand end of the power module. Push it until it snaps into place.
8. Check for the correct fusing arrangement (*see Section 6.3*).

### NOTE:

**Be sure the indicator pin is facing out and the alignment arrow is pointing to the left.**

9. Replace the cover/fuse block assembly.
10. Verify that the indicator pin shows the desired voltage.

**Figure 8: Voltage Selector Card Indicator Pin & Alignment Arrow**

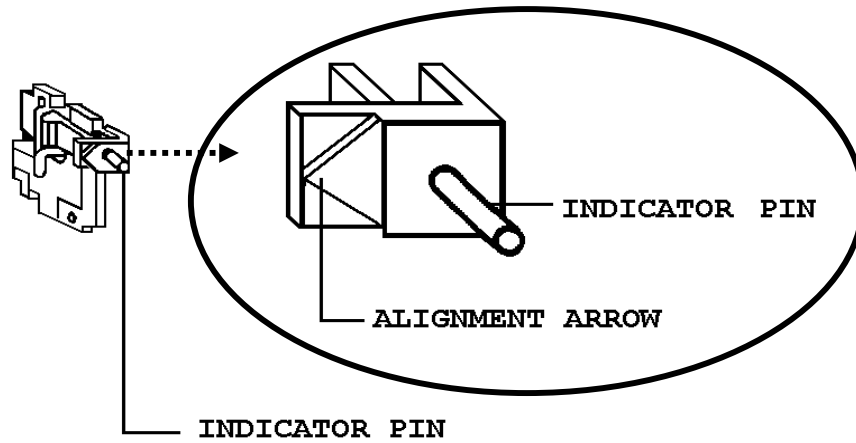

### 6.3 Fusing Arrangement

If you change the voltage on your Innova shaker, it may also be necessary to modify the fusing arrangement. If so, please follow the appropriate procedure below.

#### 6.3.1 Single to Double Fuse Conversion

1. Open the cover of the power module using a small blade screwdriver and remove the cover/fuse block assembly (see Figure 6, repeated below for easy reference).

**Figure 6: Power Module/Fuse Block**

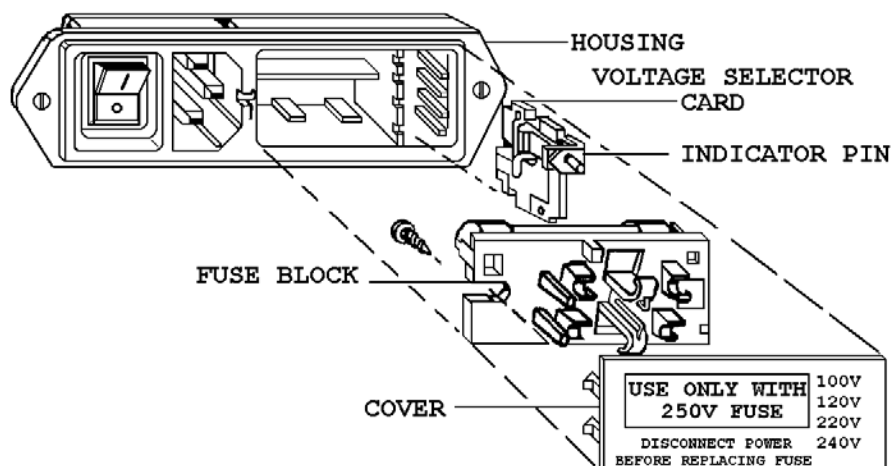

2. Loosen the Phillips screw two full turns, then remove the fuse block by sliding it up and away from the screw shaft and lifting it off the pedestal (see Figure 9).

**Figure 9: Fuse Block/Cover Assembly**

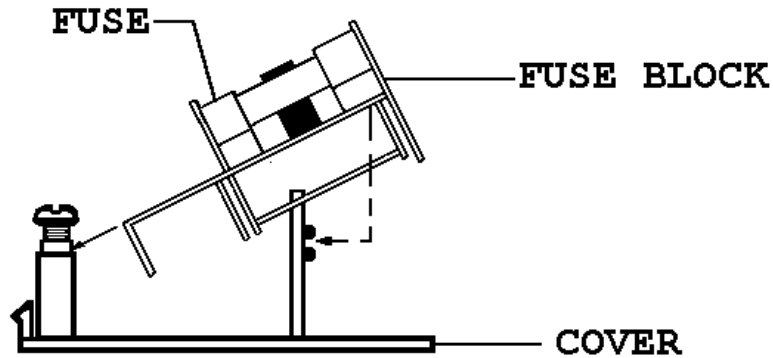

4. Invert the fuse block and slide it back onto the Phillips screw and pedestal. Tighten the Phillips screw.
5. Verify the correct fusing arrangement (see Figures 10a and 10b).
6. Replace the cover onto the power module.

**Figure 10a: Double Fuse Arrangement**

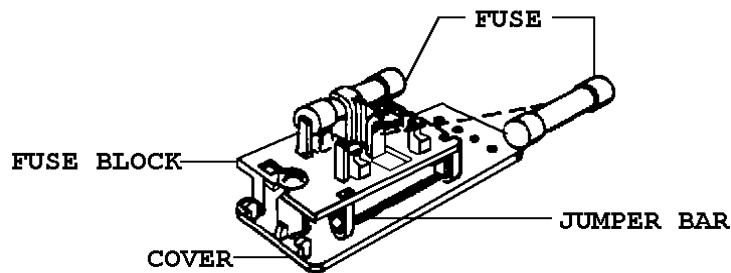

**Figure 10b: Single Fuse Arrangement**

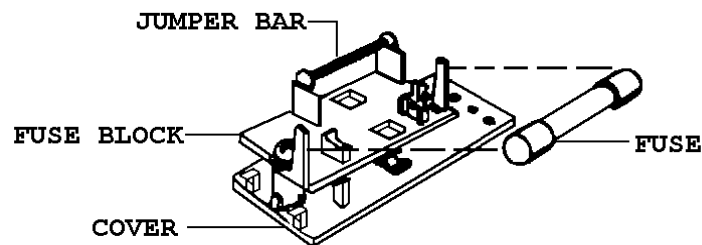

**CAUTION!**

All of the following procedures are to be performed by an authorized service engineer only. Interventions by anyone else may void the warranty and may result in damage to the product.

#### 6.4 Removing the Subplatform

With reference to Figure 11, the authorized service technician will:

1. Remove the platform by loosening the four platform locking knobs, then lifting the platform off.
2. Remove the foam pad.
3. Remove the nine screws that hold the subplatform in place: three screws around each of the bearings.
4. Lift the upper housing straight up and clear the bearing retainers.

**Figure 11: Subplatform Cutaway**

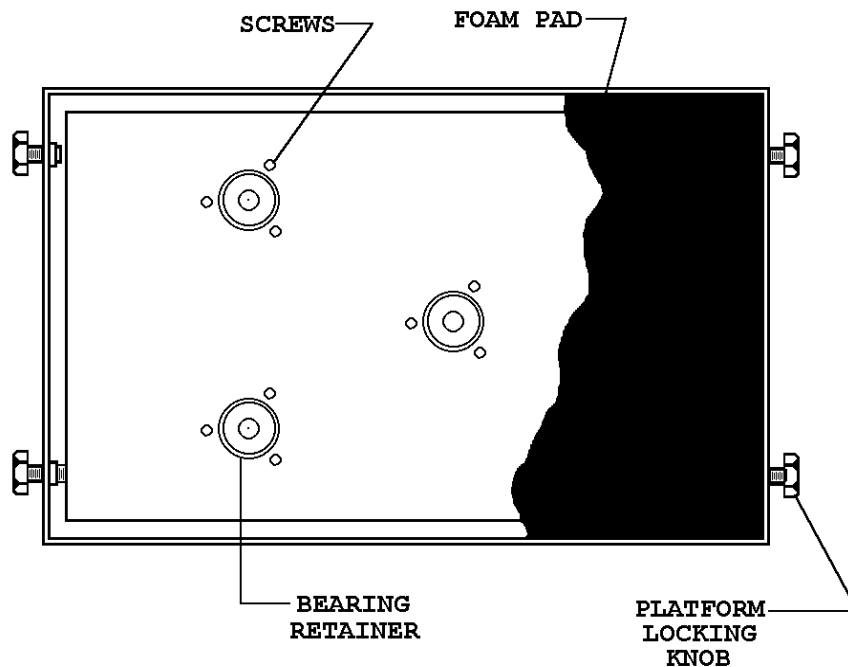

## 6.5 Replacing the Drive Belt

With reference to Figure 12, the authorized service technician will:

1. Remove the platform and subplatform (*see Section 6.4*).
2. Remove the old belt by exerting a slight upward pressure on the belt near the large pulley, then rotating the pulley. The belt should feed **out** of the groove and come free.
3. Install a new belt (NBS part number R-243) by slipping it onto the drive shaft and guiding it onto the groove on the large pulley. Rotate the large pulley until the belt is fully seated in the groove.
4. Check the belt tension by applying a slight finger pressure to the belt midway between the two pulleys. The belt should deflect approximately 3/8 inch (9.5 mm).
5. If belt tension needs adjustment, proceed to Section 6.5.1 below. If no adjustment is required, proceed to Section 6.6 below to reinstall the subplatform.

**Figure 12: Drive Belt Replacement & Adjustment**

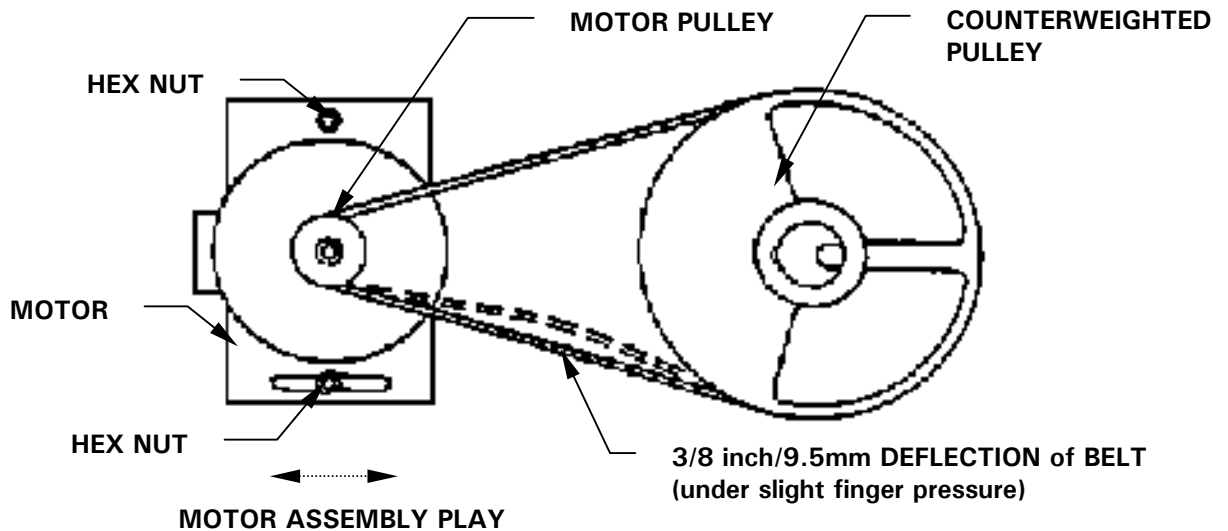

### 6.5.1 Adjusting Belt Tension

1. Loosen the two hex nuts on the motor assembly.
2. Move the motor assembly until the belt is tight.
3. Tighten the hex nuts and recheck the belt tension by exerting pressure on the belt. The belt should deflect approximately 3/8 inch (9.5 mm).
4. Reinstall the subplatform (*see Section 6.6 below*).

## 6.6 Reinstalling the Subplatform

1. Rotate all three bearing retainers to face toward the extreme left, as shown in Figure 13.
2. Carefully replace the upper housing, engaging all three retainers.
3. Tap the housing lightly and evenly until the sheet metal seats on the retainers.



### NOTE:

Approximately 1/16 inch (1.6 mm) of each retainer will protrude through the housing.

Figure 13: Bearing Housing Retainers

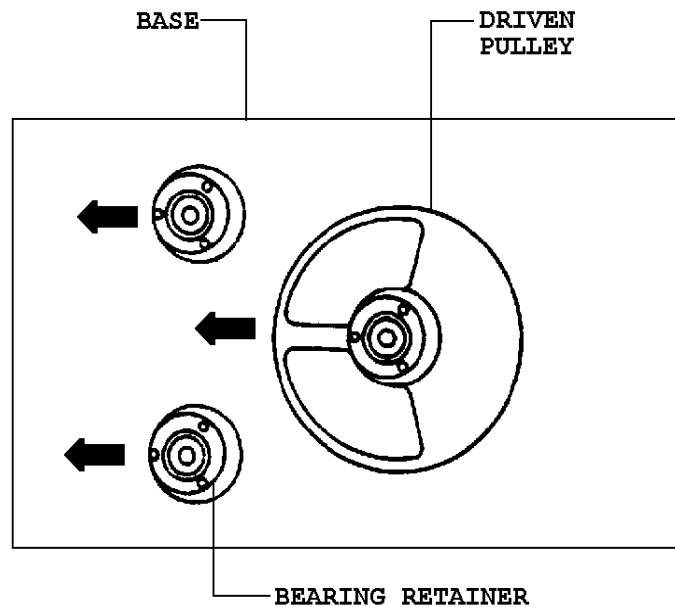

4. Reinstall the nine screws, securing them evenly, but *do not tighten them yet*.
5. Rotate the bearing housing by hand several times, then evenly tighten the nine screws until they seat firmly.
6. Replace the foam pad and platform, and reconnect the power cord. The unit is now ready for operation.

## 6.7 Replacing the Motor Assembly

1. Remove the platform and subplatform (*see Section 6.4*).
2. Remove the two hex nuts and washers that retain the motor mounting plate (*see Figure 14*).

**Figure 14: Motor/Mounting Plate Assembly**

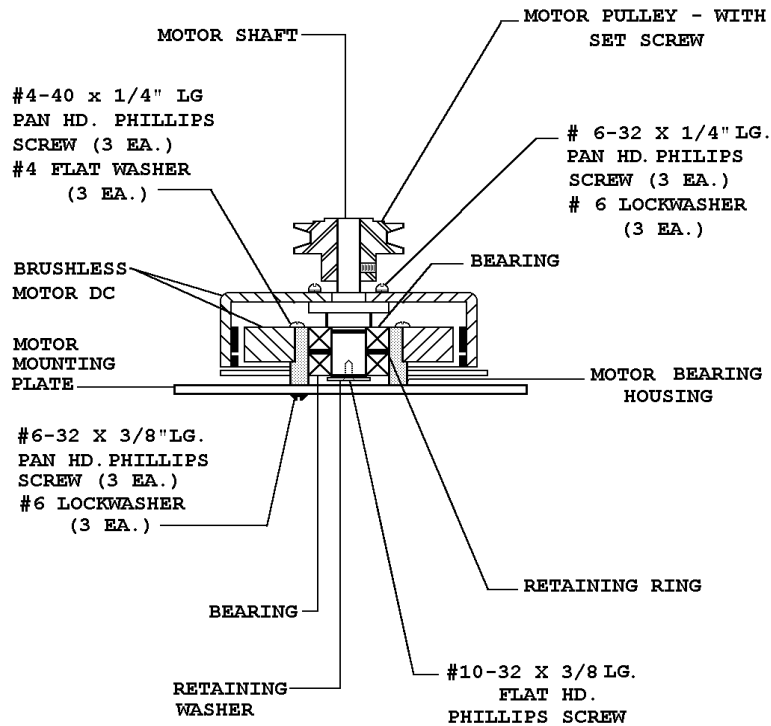

3. Remove the belt and carefully disconnect the electrical harness connector from the motor assembly (*after noting the orientation of the electrical connector*).
4. Remove the motor assembly.
5. Mount the new motor assembly (NBS part number M1190-5320) onto the casting using the hex nuts and washers removed in step 1. Tighten the nuts just until they come into contact with the motor mounting plate.
6. Connect the harness, oriented as previously noted, to the motor assembly.
7. Guide the belt onto the pulley grooves. Using a straight edge across the pulleys, adjust the height of the motor pulley so the belt is parallel to the base.
8. Tighten the set screw in the motor pulley.
9. Adjust the belt tension to have approximately 3/8 inch (9.5 mm) deflection (as explained in Section 6.5.1).

## 6.8 MAINT Indicator

After the shaker has been operating for 10,000 hours accumulated running time, the **MAINT** indicator light on the control panel will light. Only an NBS Service Engineer can turn off this light, because it indicates that a routine maintenance check is recommended. A regular schedule of routine maintenance is an excellent way to keep your valuable equipment performing optimally for years of reliable service.



## 6.9 Temperature Monitor Option

The Temperature Monitor option package (NBS part number M1190-9909) is available for both Innova 2000 and 2050 models. When installed, this option provides:

- **Digital Temperature Readout**  
The temperature of the liquid in any vessel or the ambient temperature may be monitored with an RTD-based electronic device and the value shown on the shaker's LED display.
- **Remote Monitoring**  
0-5V analog recorder output for both temperature and speed. Can be used with an external chart recorder or computer which has a data acquisition card.

The Temperature Monitor option consists of an internal electrical interface, RTD temperature probe and analog output for chart recorder or computer. The package **does not** include a chart recorder.

Before scheduling the Service Engineer for field installation, it is a good idea to confirm against the packing list that you have received all the parts.

### 6.9.1 ESD Precautions

Because the Service Engineer will be working with electronic boards and components, the following precautions will be taken:



#### **CAUTION!**

**Do not attempt to change boards or electronic components unless you are a qualified service technician. Integrated circuits are extremely susceptible to damage from electrostatic discharge (ESD). Read and follow the following precautions before beginning the procedure.**

- Do not remove components from their antistatic packaging until you are ready to insert them into their sockets or to install the board.
- Before handling components or boards, touch an unpainted portion of the system unit chassis for a few seconds.
- Wear a wrist grounding strap, available from most electronic component stores.

## 6.9.2 Installing the Temperature Monitor Option

With reference to Figure 15:

1. Stop the shaker with the **START/STOP** key (if necessary), and turn the unit off using the **ON/OFF** switch.
2. Unplug the unit from the power source and remove the power cord from the shaker.
3. Remove the shaker platform and subplatform (*see Section 6.4*).

**Figure 15: Front Panel Assembly**

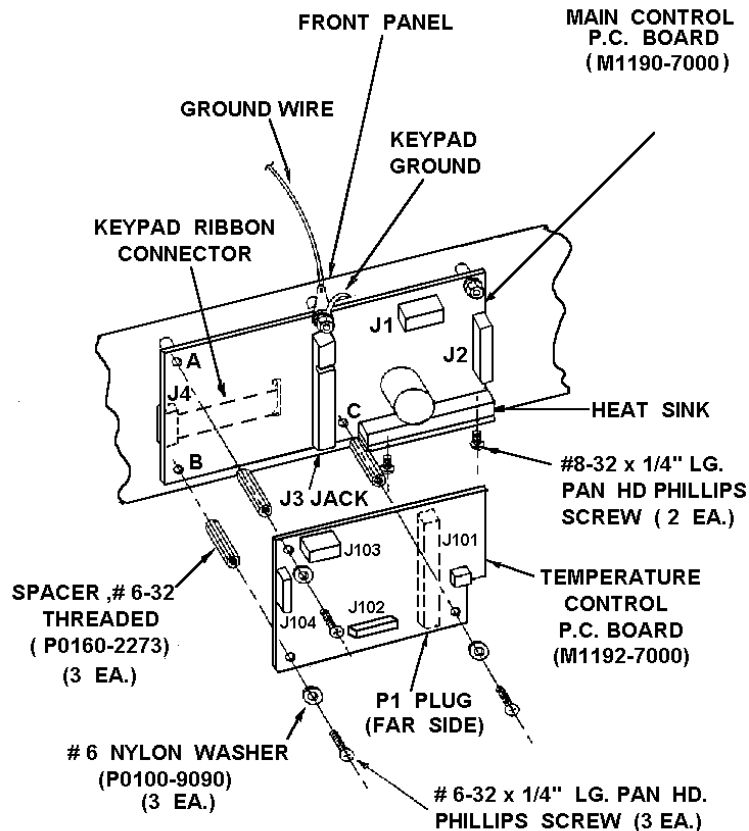

4. Remove the five screws that hold the front panel in place. Lay the front panel on its face.
5. Remove three nuts and three washers from positions A, B and C on the main control board.
6. Screw on the three hex spacers (P0160-2273, provided in the kit) in positions A, B and C.
7. Align the mating connector on the temperature module PC board with the option connector on the main control board and press down until the connector is seated.

8. Secure the temperature module to the main control board with the three ¼-inch screws and nylon washers provided.
9. Remove the jack cover plate at the rear of the shaker (*see Figure 1b*). Retain the mounting hardware.
10. Mount the RTD jack (round connector) with the hardware used to hold the cover plate. Mount the chart recorder connectors with the hardware provided in the jack screw kit (P0100-7641).
11. Carefully route both cables along the lower right side of the shaker and secure with cable clamps and ½-inch long screws provided.
12. Connect the 4-pin connector coming from the chassis harness assembly to J101 (must cut tie wrap).
13. Connect the RTD cable's 6-pin connector to J103 on the temperature control module.
14. Connect the chart recorder cable's 10-pin connector to J104 on the temperature control module.

**CAUTION!**

**Before tightening the screws, make sure that there are no wires pinched between the front panel and the chassis.**

15. Carefully put the front panel back in place and secure it with screws.
16. Place the unit on its side.
17. Mount the RTD bracket assembly (M1194-5000) with the ½-inch pan head screws provided.
18. Place the unit in its normal operating position.
19. Reassemble the subplatform and platform (*see Section 6.6*).
20. Reconnect the power cord to the unit.

### 6.10 Capacity Upgrade Option

This kit (NBS part number M1190-9910), which upgrades the capacity of an Innova 2000 to that of an Innova 2050, consists of counterweighting, hardware and a subplatform for 12 x 16-inch (30.5 x 40.6 cm) platforms. The platform, however, must be purchased separately.

Before scheduling the Service Engineer for field installation, it is a good idea to confirm against the packing list that you have received all the parts.

### 6.10.1 Installing the Capacity Upgrade Option

1. Turn the power off using the **ON/OFF** switch, and disconnect the power cord.
2. Remove the subplatform (*see Section 6.4*).

With reference to Figure 16:

3. Be sure that the lockwasher is under the screw head. Mount the counterweights to the bottom of the large pulley by inserting the 1/4-20 screw through each counterweight's mounting hole.

**Figure 16: Counterweight & Pulley Assembly**

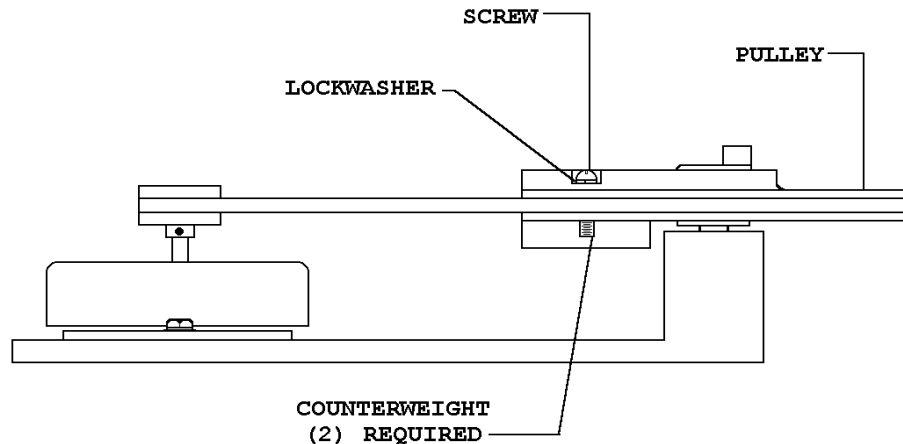

4. Hold the counterweights and tighten the screw sufficiently so that the counterweights do not move.
5. Replace the subplatform **using the new 12 x 16-inch (30.5 x 40.6 cm) unit** (*see Section 6.6 for procedure*).
6. Insert the new 12 x 16-inch (30.5 x 40.6 cm) foam pad into the subplatform and install a 12 x 16-inch (30.5 x 40.6 cm) platform. Be sure to secure the platform with the thumb screws.

# 7 PARTS & ACCESSORIES

## 7.1 *Innova 2000 Platforms*

<b>NBS Part Number</b>	<b>Number of Clamps</b>	<b>Description (11 x 13 in. / 28 x 33 cm Platform)</b>
AG2-UT	--	Utility Carrier
AG2-00	--	Utility Tray
M1001-0240	--	Universal Platform
AG2-10	60	for 10ml Erlenmeyer flasks
AG2-25	32	for 25ml Erlenmeyer flasks
M1190-9915	20	for 50 ml Erlenmeyer flasks
M1190-9916	12	for 125 ml Erlenmeyer flasks
M1190-9917	8	for 250/300 ml Erlenmeyer flasks
M1190-9918	6	for 500 ml Erlenmeyer flasks
AG2-TA25	18	Test Tube Rack, Slant

All above platforms constructed of stainless steel.

## 7.2 *Innova 2050 Platforms*

<b>NBS Part Number</b>	<b>Number of Clamps</b>	<b>Description (12 x 16 in. / 30.5 x 40.6 cm Platform)</b>
M1190-9907	--	Utility Carrier
M1190-9908	--	Utility Tray
M1190-9900	--	Universal Platform
M1190-9901	86	for 10ml Erlenmeyer flasks
M1190-9902	48	for 25ml Erlenmeyer flasks
M1190-9903	33	for 50 ml Erlenmeyer flasks
M1190-9904	20	for 125 ml Erlenmeyer flasks
M1190-9905	12	for 250/300 ml Erlenmeyer flasks
M1190-9906	8	for 500 ml Erlenmeyer flasks
M1190-9911	6	for 1-liter Erlenmeyer flasks
M1190-9912	3	for 2-liter Erlenmeyer flasks

All above platforms constructed of stainless steel.

### 7.3 Accessory Flask Clamps

NBS Part Number	Clamp Style
ACE-105	for 10ml Erlenmeyer flasks
ACE-255	for 25ml Erlenmeyer flasks
ACE-505	for 50 ml Erlenmeyer flasks
ACE-125S	for 125 ml Erlenmeyer flasks
ACE-250S	for 250/300 ml Erlenmeyer flasks
ACE-500S	for 500 ml Erlenmeyer flasks
ACE-1000S	for 1-liter Erlenmeyer flasks
ACE-2000S	for 2-liter Erlenmeyer flasks
ACE-4000S	for 4-liter Erlenmeyer flasks
ACE-6000S	for 6-liter Erlenmeyer flasks
ACFE-2800S	for 2800 ml Fernbach flasks
ACSB-500S	for 500 ml Media Bottles
ACSB-1000S	for 1-liter Media Bottles

All above clamps constructed of stainless steel.

### 7.4 Service Parts

Model	NBS Part Number	Description	Quantity
Innova 2000 & 2050	P0380-3830	0.200A Fuse	1
	P0380-3410	1.0A 5x20 mm Fuse	1
	EF-104	1.0A 3AG Fuse	1
	P0420-1610	10VA Transformer	1
	M1190-5300	80VA Transformer	1
	P0320-0340	4100 uF Capacitor	1
	P0460-4091	Diode Bridge	1
	P0360-4040	130V Varistor	2
	M1190-5320	Small Motor Assembly	1
	M1190-9940	Main Control PCB	1
	M1190-5000	Membrane Sw. Panel	1
	P0460-2200	Power Entry Module	1
	P0720-2053	Power Cord 120V 10A	1
	P0720-2021	Power Cord 220V	1
	P0180-0020	Bearing, Shielded, lower	6
	M1190-6340	Bearing Assembly	3
	R-243	Drive Belt	1
	M1190-6330	Bearing Housing Assembly	1
	H-1386	Knob	4
	M1194-8000	Stainless Steel RTD (optional)	1
Innova 2000 only	M1190-9501	Foam Pad	1
Innova 2050 only	M1190-9502	Foam Pad	1







**NOTE:**

**At 25-400 RPM, the unit will perform to specifications with up to  $\pm 10\%$  line voltage fluctuation. To attain speed accuracy at 401-500 RPM, the line voltage cannot be lower than 5% of the rated voltage.**

**THIS PAGE IS INTENTIONALLY BLANK**

# 9 DRAWINGS

Figure 17: Control Schematic

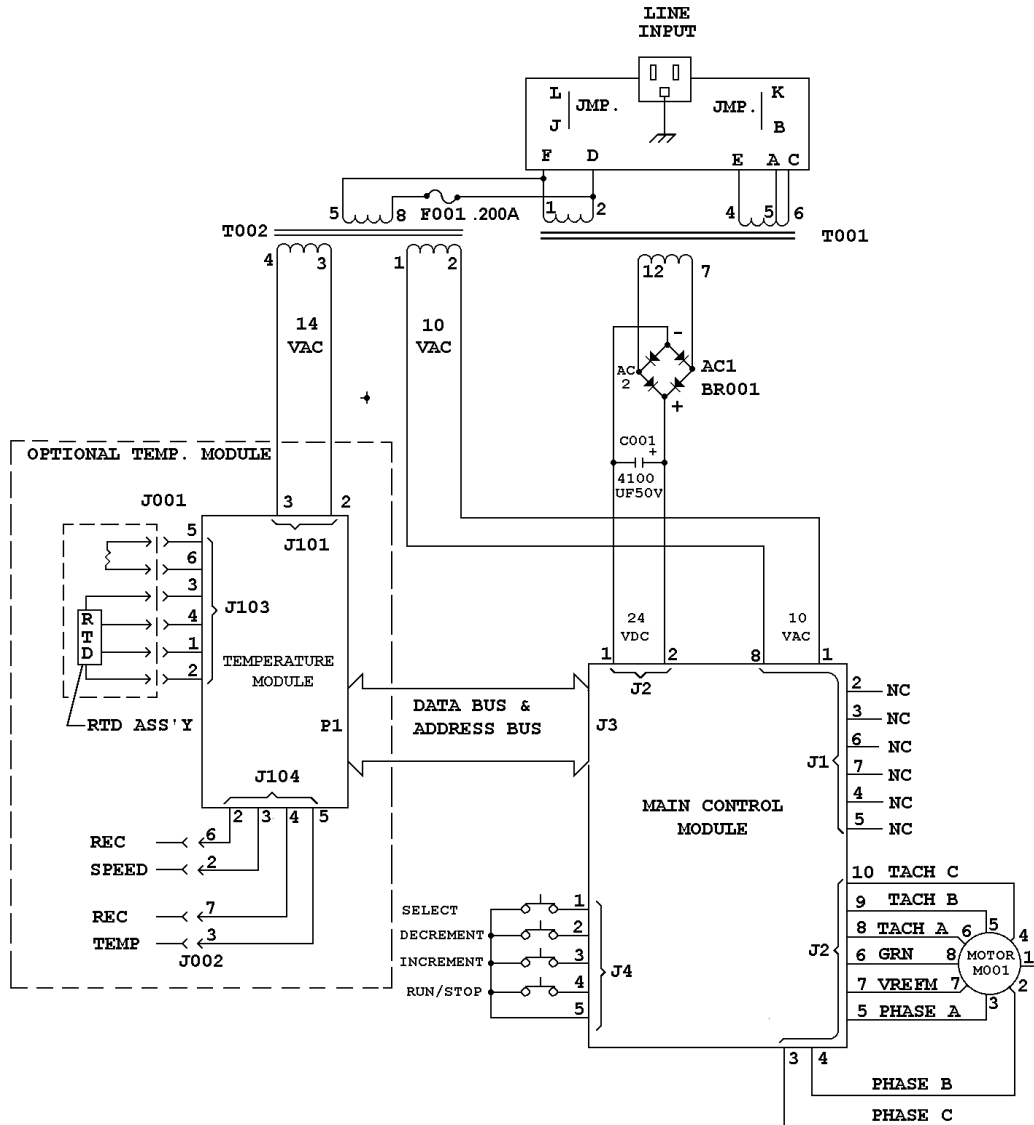

## 9.1 *List of Drawings*

<b>Figure</b>	<b>Description</b>	<b>Page</b>
1a	Front View	15
1b	Rear View	16
2	Control Panel	16
3	Counterbalanced Drive Mechanism	20
4a	Innova 2000 Operating Space	25
4b	Innova 2050 Operating Space	25
5	2- to 6-Liter Clamp Installation	28
6	Power Module/Fuse Block	33,35
7	Voltage Selector Card Orientation	34
8	Voltage Selector Card Indicator Pin & Alignment Arrow	35
9	Fuse Block/Cover Assembly	36
10a	Double Fuse Arrangement	36
10b	Single Fuse Arrangement	36
11	Subplatform Cutaway	37
12	Drive Belt Replacement & Adjustment	38
13	Bearing Housing Retainers	39
14	Motor/Mounting Plate Assembly	40
15	Front Panel Assembly	42
16	Counterweight & Pulley Assembly	44
17	Control Schematic	51

## 9.2 *List of Tables*

<b>Table</b>	<b>Description</b>	<b>Page</b>
1	User Interface Keys	18
2	Status Indicator Lights	18
3	Function Indicator Lights	18
4	Voltage Configuration Chart	23
5	Operating Space Requirements	25
6	10 to 500ml Clamp Hardware Application Chart	27
7	2- to 6-Liter Clamp Hardware Application Chart	27

# 10 INDEX

- ▼ Key, 18
- ▲ Key, 18
- #
- \*
  - \* Indicator, 18
- A**
  - Accumulated Running Time, 31
  - Alarm
    - Deactivating the, 30
    - Reactivating the, 31
    - Stopping the, 30
  - Alarms, 15
  - Alignment Arrow
    - Voltage Selection, 35
  - Ambient Temperature
    - Measuring the, 32
  - Analog Output, 31
- B**
  - Bearing Housing Retainers, 39
  - Bearings, 19
- C**
  - Capacity Upgrade Option, 21, 43
    - Installing the, 44
  - CAUTION
    - Symbol for, 7
  - Chart Recorder, 31, 41
  - Clamp Hardware Application Charts, 27
  - Clamps
    - Installation of, 27
  - Cleaning, 32
  - Construction, 19
  - Continuous Run, 29
  - Control Panel, 16, 17
  - Control Schematics, 51
  - Conversion
    - 2000 to 2050, 21
    - Converting Innova 2000 to 2050, 43
    - Copyright Notice, 7
    - Counterweight & Pulley Assembly, 44
- D**
  - Dimensions, 25
  - Disclaimer Notice, 7
  - Double Fuse
    - Drawing of, 36
  - Drawing List, 52
  - Drive Belt Tension
    - Adjusting the, 38
  - Drive Mechanism, 19
- E**
  - Electrical Connections, 26
  - Electronic Boards, 20
  - Electronic Components
    - Precautions for, 41
  - Electrostatic Discharge, 41
  - Err Message, 32
  - ESD, 41
- F**
  - Flask Clamps, 46
    - Installation of, 26
  - Front Panel Assembly
    - Drawing of, 42
  - Front View, 15
  - Function Indicators, 18
  - Fuse Block, 33, 35
  - Fuse Block/Cover Assembly, 36
  - Fuse Conversion
    - Double to Single, 35
    - Single to Double, 35
  - Fuse Holder, 16
  - Fuse Replacement, 33
  - Fusing Arrangement, 35

- 
- H**
- HRS Indicator, 18
- I**
- Indicator Lights, 16, 17  
Indicator Pin  
  Voltage Selection, 35  
Inspection, 23  
Installation, 25  
International Offices  
  List of, 3
- K**
- Keypad, 16, 17
- L**
- LED Display, 16, 17  
Location, 25
- M**
- MAINT Indicator, 18, 31, 32, 40  
Maintenance, 32  
Manual Conventions, 7  
Motor, 19  
Motor Assembly  
  Replacing the, 39  
MUTE Indicator, 18
- N**
- NOTE  
  Symbol for, 7
- °C Indicator, 18, 31
- O**
- ON/OFF Switch, 29  
Operating Space Requirements, 25  
Options, 21
- P**
- Parts, 46  
PI Microprocessor Controller, 15
- Platforms, 15, 19, 23  
  Innova 2000, 45  
  Innova 2050, 45  
  Installation of, 26  
Power Entry Module, 33, 35  
Powering Up, 29
- R**
- Rear View, 16  
Remote Monitoring, 20, 41  
Replacement Partd, 46  
Replacing a Fuse, 33  
RPM Indicator, 18  
RTD, 20, 31, 41  
Running Time, 31
- S**
- SELECT Key, 18  
Service, 33  
Service Parts, 46  
SET Indicator, 18  
Setpoint  
  Checking a, 29  
Single Fuse  
  Drawing of, 36  
Specifications  
  Innova 2000, 47  
  Innova 2050, 48  
START/STOP Key, 18, 29  
Starting Shaker, 29  
Status Indicators, 18  
Subplatform  
  Reinstalling the, 39  
  Removing the, 37
- T**
- Table List, 52  
Table of Contents, 11  
Temperature Monitor Option, 20, 21, 31, 41  
Temperature Probe, 31, 41  
Temperature Readout, 41  
TIME Indicator, 18  
Timed Run, 17  
Timer, 15

---

    Cancelling the, 30  
Total Running Time, 31  
Troubleshooting, 33

### U

Universal Power Module, 16, 26  
Unlimited Run, 29  
Unpacking, 23  
User Interface Keys, 18

### V

Vessel Temperature

    Measuring a, 32  
Voltage  
    Changing the, 34  
Voltage Configuration, 23, 26  
Voltage Selector Card, 16, 34, 35

### W

WARNING  
    Symbol for, 7  
Warranty, 9, 31