

Operating manual

Analogue refractometer

KERN	ORA 1 SA	Seawater salinity
	ORA 2 SA	NaCL%
	ORA 3 SA	NACL% Brix%

Version 1.0
01/2015
GB

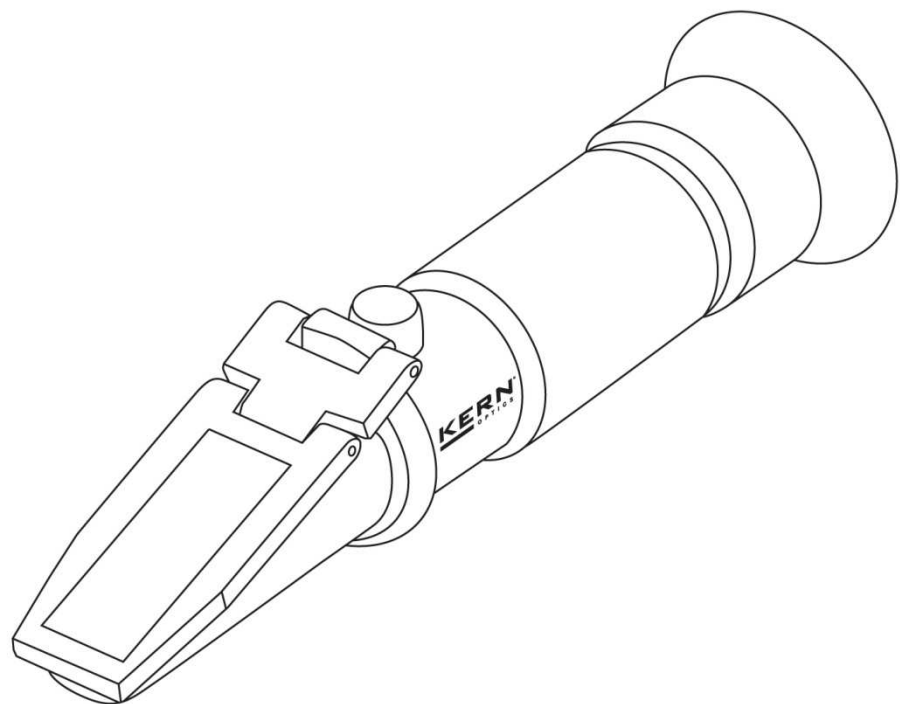



KERN ORA
Version 1.0 01/2015
Operating manual
Analogue refractometer

Contents

1	Technical data	3
2	Device parts and description	4
3	General information	5
3.1	Intended use	5
3.2	Warranty	5
4	Basic safety information	6
4.1	Follow the instructions in the operating manual	6
4.2	Warning	6
5	Supplied items	7
6	Before the first use	7
7	Use/measurement	7
7.1	Zero point calibration	8
7.2	Automatic temperature compensation (ATC).....	8
7.3	Additional advice.....	9
7.4	Measuring procedure	9
8	Cleaning and maintenance	10
9	Storage	10
10	Service	10
11	Disposal	10
12	Additional information	10

1 Technical data

Model	Measuring range	Accuracy	Dimensions (mm)	Weight (g)
ORA 1 SA	0-100‰ 1.000-1.070	1‰ 0.005	27 x 40 x 190	175
ORA 2 SA	0-28%	0.2%	27 x 40 x 160	175
ORA 3 SA	0-28% NaCl 0-32% Brix	0.2 % 0.2 %	27 x 40 x 160	175

Example scale on the ORA 2 SA

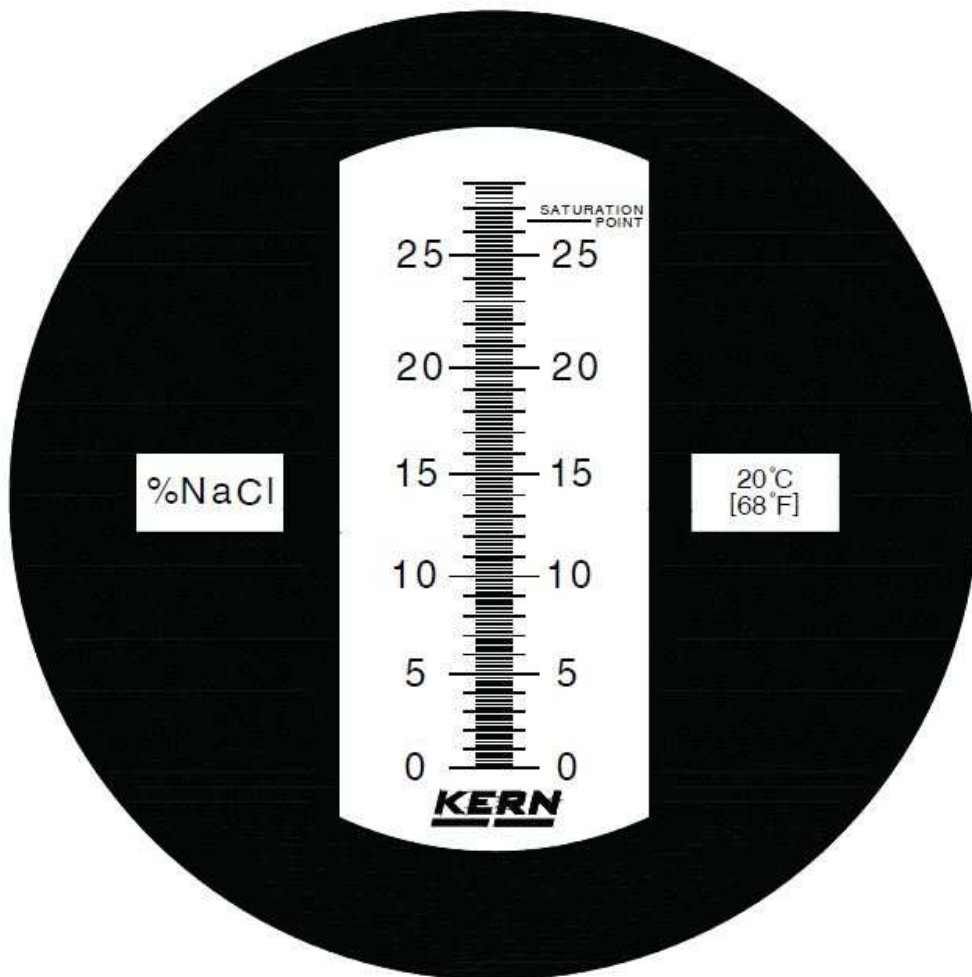

2 Device parts and description

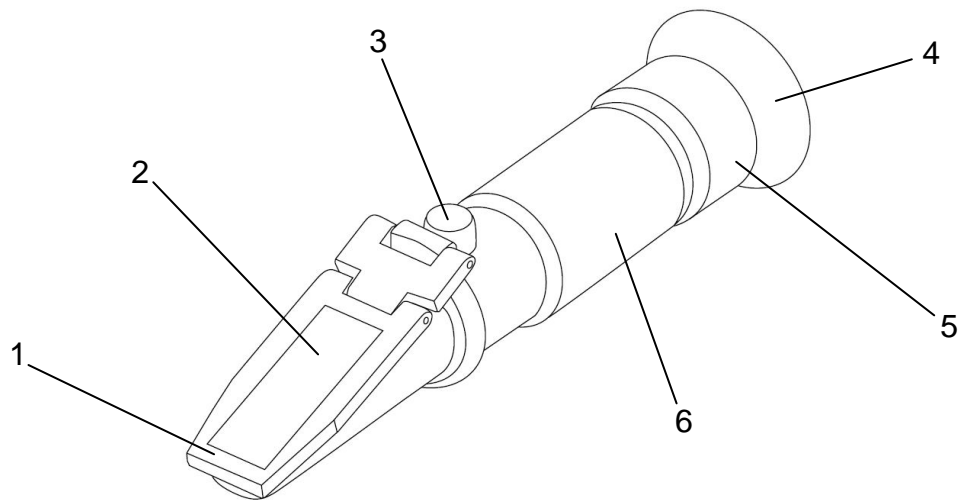

1. Prism cover
2. Prism surface
3. Adjustment screw
4. Eyepiece with rubber eyeshade
5. Diopter adjustment ring
6. Optical tubes with rubber grip

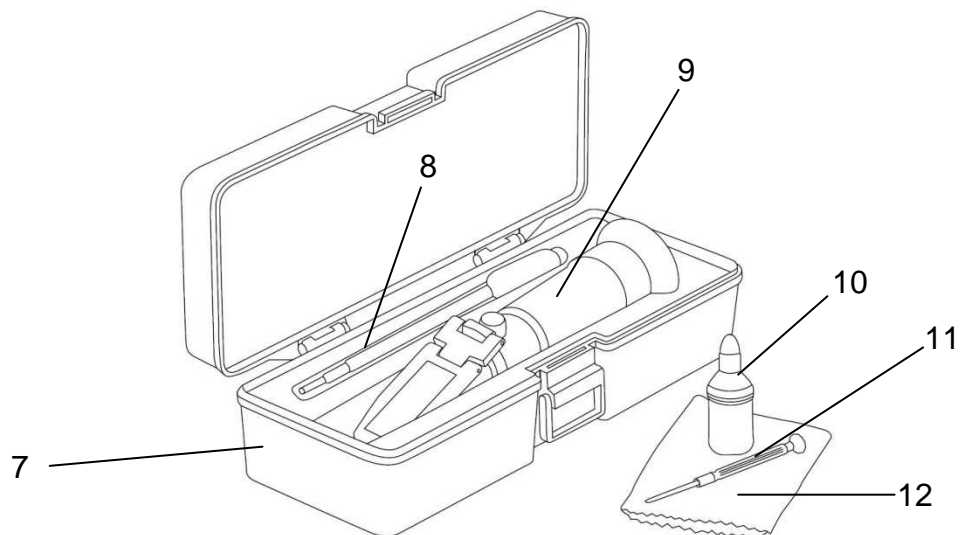

7. Storage box
8. Pipette
9. Refractometer
10. Distilled water / calibration liquid
11. Adjustment tool
12. Cleaning cloth

3 General information

3.1 Intended use

The refractometer is a measuring device for determining the refractive index of transparent substances in liquid or in some cases also in solid state. It is used to observe the behaviour of light as it passes from a prism with known properties to the substance being tested.

Use of the refractometer for other purposes is contrary to its intended use and may be hazardous. The manufacturer shall not be liable for any damages caused by improper use.

3.2 Warranty

The warranty shall be void in the event of:

- ⇒ Failure to observe the instructions in the operating manual
- ⇒ Use for purposes other than those described
- ⇒ Modifications or opening the device housing
- ⇒ Mechanical damage and/or damage resulting from media, liquids, natural wear and tear

4 Basic safety information

4.1 Follow the instructions in the operating manual



- ⇒ Carefully read through the operating manual even if you have prior experience with KERN refractometers.
- ⇒ The original document in German is the definitive version. All other language versions are non-authoritative translations.

4.2 Warning

- ⇒ Do not let acids come into contact with skin or eyes. If acid comes into contact with skin, flush with copious amounts of water. Shower if larger areas of skin are affected.
- ⇒ If acid comes into contact with eyes, keep the eyelid open and flush the eye with running lukewarm water from the outer corner to the inner corner. Flush eyes for at least 15 minutes. Then consult a doctor or ophthalmologist immediately.
- ⇒ Thoroughly clean the refractometer after each use.
- ⇒ The refractometer must not be exposed to extreme temperatures, high mechanical stresses, strong direct sunlight or high humidity.
- ⇒ This refractometer is not a toy. Keep out of reach of children.
- ⇒ Make sure that you will not be hit by anything else while you are using the refractometer, as this could cause serious eye injuries.
- ⇒ The rubber eyeshade
- ⇒ may cause irritation when in prolonged contact with the skin. If this happens, consult your doctor.
- ⇒ Do not touch the lenses with your fingers.

5 Supplied items

After unpacking and before using the device for the first time, check that all listed parts have been supplied. Replace damaged or faulty parts immediately and do not put them into operation.

- ⇒ Refractometer
- ⇒ Storage box
- ⇒ Pipette
- ⇒ Adjustment tool
- ⇒ Cleaning cloth
- ⇒ Distilled water / calibration fluid

6 Before the first use

Remove the protective film (if present) from the prism surface [2] and check that the rubber eyeshade [4] is fitted correctly.

7 Use / measurement

The refractometer can be used to quickly and accurately determine the refractive index of transparent substances, liquid or solid ones. To ensure correct measurement, the measuring device should be adjusted before measurements are carried out. Please make sure your hands are dry before handling the measuring device.

7.1 Zero point calibration

- ⇒ Hold up the refractometer against a sufficiently bright light source and look through the eyepiece [5], holding the rubber eyeshade [4] closely against your eye/glasses.
- ⇒ Rotate the eyepiece [5] to adjust it for your eyesight, until you can see the scale sharply.
- ⇒ Open the prism cover [1].
- ⇒ Thoroughly clean the prism [2] and the underside of the prism cover [1] using a soft cloth or soft paper (with alcohol if necessary), and wipe dry. Water should only ever be applied to the measuring prism, not to other parts of the device.
- ⇒ Now apply a few drops of the calibration liquid [10] onto the prism surface [2].
- ⇒ close the prism cover [1]. The amount of fluid should be sufficient to moisten most of the prism surface. There should not be any air bubbles between the measuring prism [2] and prism cover [1].
- ⇒ Wait about 30 seconds to allow the temperatures of the test fluid and prism to equalise.
- ⇒ Look through the eyepiece [4] while pointing the refractometer's prism surface [2] at a bright light source.
- ⇒ Through the eyepiece [4], you will see a bright and a blue field. The boundary line between them shows the refractive index value on the scale which is also visible through the eyepiece [4].
- ⇒ Use the supplied adjustment tool [11] to turn the adjustment screw [3] behind the prism surface [2] (under the rubber cap), and adjust the scale so that the measuring device is optimally set up. The bright/dark boundary line should be at 0% Brix. For refractometers which are not set to 0% Brix using distilled water and have a special calibration fluid, set the bright/dark boundary line to the calibration line in the prism. The room temperature should be +20°C.
- ⇒ For refractometers without automatic temperature compensation (ATC): Convert the measured value to take account of the deviation in room and sample temperature from +20 °C. (See the table in section 13 at the end of this instruction manual.)
- ⇒ Repeat step 4 (cleaning).

7.2 Automatic temperature compensation (ATC)

Automatic temperature compensation (ATC).

The handheld refractometer is equipped with automatic temperature compensation.

This automatically compensates for measurement differences resulting from differences in sample temperatures. It operates between +10 °C and +30 °C.

ATC eliminates the need to convert values using a temperature correction table.

7.3 Additional advice

It is important that the samples being measured are representative samples. For samples that evaporate easily, measurements should be carried out quickly. If possible, the samples should be at the same temperature as the measuring device to achieve an accurate measurement result.

7.4 Measuring procedure

- ⇒ Make sure your hands are dry before handling the refractometer.
- ⇒ Open the prism cover [1] and use the supplied pipette [8] to apply a few drops of the sample liquid onto the prism surface [2], then close the prism cover [1]. Spread the liquid evenly by slightly pressing down the prism cover [1].
- ⇒ Hold the device horizontally and wait about 30 seconds (for optimal temperature equalisation between the sample and device).
- ⇒ View the measurement scale through the eyepiece [4]. Point the prism surface [2] of the refractometer at a bright light source while doing this.
- ⇒ Rotate the adjustment ring [5] on the eyepiece [4] to adjust the focus.
- ⇒ The boundary line will move on the measurement scale depending on the concentration. This bright/dark boundary line shows the result on the scale.
- ⇒ If the temperature deviates from +20 °C, correct the measured result using the corresponding value from the temperature correction table (see section 13).
- ⇒ Carefully clean the supplied pipette [8] and the refractometer after carrying out the measurement.

Important!



After every measurement, use a lint-free, absorbent cloth to remove the fluids from the prism surface [2] and prism cover [1]. Then carefully clean the prism and prism cover using a cloth moistened with water or if necessary alcohol, and dry both parts using a soft, dry and lint-free cloth. Avoid rubbing the prism [2].

8 Cleaning and maintenance

Clean the refractometer using a clean, lint-free cloth moistened with water or if necessary alcohol. Do not use any aggressive or abrasive cleaning agents. Never immerse the device in water or hold it under running water. Never handle the device with wet or damp hands.

Never touch the measuring prism [2] with hard tools made from plastic, wood, rubber, metal, glass etc. Hard objects can quickly damage the relatively soft prism glass, resulting in measurement errors.

The refractometer is maintenance-free.

Cleaning should be carried out immediately before and after each use of the refractometer to maximise its life and optimise measurement results.

9 Storage

Store the refractometer in a dry, non-corrosive environment.

10 Service

After reading this operating manual, if you have any questions about setting up or using the refractometer, or if any unexpected problem occurs, please contact your dealer. The device housing may only be opened by trained service technicians authorised by KERN.

11 Disposal

The packaging consists of environmentally friendly materials which can be disposed of via local recycling facilities.

The device and storage box should be disposed of by the operator in accordance with applicable national or regional regulations at the place of use.

12 Additional information

The product may differ slightly from the illustrations.
Avoid exposing the refractometer to direct sunlight.
Never bring the refractometer into contact with solvents.