

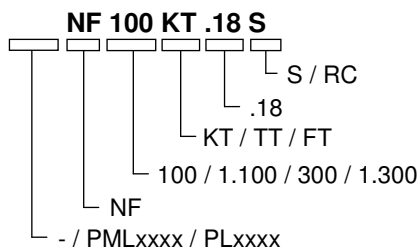

# Diaphragm Laboratory Pump

# LIQUIPORT®



## Operating instructions

Read and observe these operating and installation instructions!

An additional letter prefixing the FEM model code is a country-specific designation, and does not have any technical significance.



KNF FLODOS AG  
Wassermatte 2  
6210 Sursee, Switzerland  
Tel. +41 (0)41 925 00 25  
Fax +41 (0)41 925 00 35  
[www.knf-flodos.ch](http://www.knf-flodos.ch)  
[info@knf-flodos.ch](mailto:info@knf-flodos.ch)

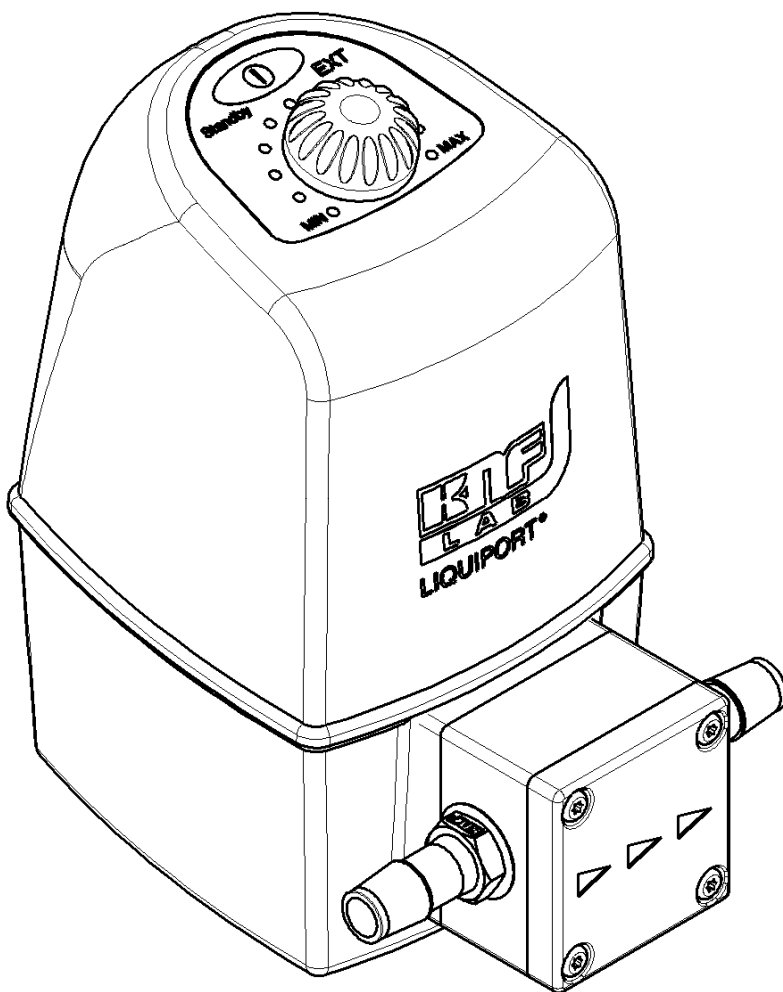

### Items included on delivery:

- Liquiport® Laboratory pump
- Mains plug
- RC cable (for RC version only)
- Operating manual

### Safety provisions

The Liquiport® laboratory pump complies with the safety provisions of the EC low-voltage directive 2006/95/EC and the EC directive on electromagnetic compatibility 2004/108/EC. The following harmonised standards are applicable:

- EN 61010-1
- EN 61326-1

Contents	Page	Contents	Page
<b>1. About this document</b>	<b>3</b>	6.6. Transport and interim storage	17
1.1. Use of the operating and installation instructions	3	<b>7. Operation</b>	<b>18</b>
1.2. Symbols and markings	3	7.1. Initial start-up	18
<b>2. Use</b>	<b>4</b>	7.2. Operating controls	19
2.1. Intended use	4	7.3. Starting the pump	19
2.2. Improper use	4	7.4. Stopping the pumping operation	19
<b>3. Safety</b>	<b>5</b>	7.5. Adjusting the flow rate	20
<b>4. Technical data</b>	<b>7</b>	<b>8. RC version – external actuation</b>	<b>21</b>
4.1. Pump materials	7	8.1. External actuation analogue input	21
4.2. Hydraulic ratings	8	8.2. Start/stop pulse input	22
4.3. Hydraulic connections	9	8.3. Foot switch	23
4.4. Electrical Data	10	8.4. Digital output	23
4.5. Other parameters	10	<b>9. Servicing</b>	<b>24</b>
4.6. External actuation (RC version only)	11	9.1. Servicing schedule	24
<b>5. Assembly and function</b>	<b>12</b>	9.2. Cleaning	24
5.1. Design of the laboratory pump	12	9.3. Cleaning/replacing valve plates and pump diaphragm	25
5.2. Operating principle	12	<b>10. Troubleshooting</b>	<b>28</b>
<b>6. Installation and connection</b>	<b>13</b>	<b>11. Spare parts and accessories</b>	<b>30</b>
6.1. Installation	13	11.1. Spare parts	30
6.2. Electrical connection	15	11.2. Accessories	30
6.3. External drive (RC version)	15	<b>12. Decontamination declaration</b>	<b>31</b>
6.4. Hydraulic connection	16		
6.5. Shutdown	17		

## 1. About this document

### 1.1. Use of the operating and installation instructions

The operating and installation instructions are part of the pump.

- Pass on the operating and installation instructions to the next owner.

Project pumps

Customer-specific project pumps (pump models which begin with "PL" or "PML") may differ from the operating and installation instructions.

- In the case of project pumps, take note of any additionally agreed specifications.

### 1.2. Symbols and markings

#### Warning



**WARNING**

This symbol indicates a potential danger.

It also indicates the possible consequences of failure to observe the warning. The signal word (i.e. "Warning") indicates the level of danger.

- This specifies measures for avoiding the danger and the consequences of failure to implement these measures.

#### Danger levels

Signal word	Meaning	Consequences if not observed
<b>DANGER</b>	warns of immediate danger	Death or serious injuries and/or serious damage to property are the consequence.
<b>WARNING</b>	warns of possible danger	Death or serious injuries and/or serious damage to property are possible.
<b>CAUTION</b>	warns of a potentially dangerous situation	Minor injuries or damage to property are possible.

Tab. 1: Danger levels

#### Other information and symbols

- This indicates an activity (step) that needs to be carried out.

1. This indicates the first step of an activity to be carried out. It will be followed by other consecutively numbered steps.

- i** This symbol indicates important information.

## 2. Use

### 2.1. Intended use

The pump is intended for transferring and metering liquids.

#### Owner's responsibility

Operating parameters and conditions

The pump must be installed and operated only in accordance with the operating parameters and conditions described in Chapter 4, Technical data.

Protect the pump from moisture.

The pump may be operated only when fully assembled.

Requirements for transferred medium

Before using a medium, check the compatibility of the materials of the pump head, pump housing, diaphragm and valves with the pumped medium.

Before starting to pump, check that the medium can be pumped safely in this specific situation.

The temperature of the medium must lie within the permissible temperature range (see Chapter 4).

The pumped medium should not contain particles as these can prevent the pump from working correctly. If this cannot be guaranteed, a filter < 50 µm with a sufficiently large filter area must be used upstream of the pump.

### 2.2. Improper use

The pump must not be operated in a potentially explosive atmosphere.

The party commissioning the pump is responsible for ensuring compliance with relevant standards if the pump is used in the medicine or food sectors.

### 3. Safety

**i** Note the safety precautions in Chapters 6. Installation and connection, and 7. Operation.

The pump is built according to the generally recognised rules of technology and in accordance with the pertinent occupational safety and accident prevention regulations. Nevertheless, dangers can result during its use, which lead to injuries to the user or others, or to damage to the pump or other property.

Only use the pump in perfect working order and in accordance with its intended use. Always ensure adherence to the operating and installation instructions and work in a safety-conscious manner.

Personnel	<p>Make sure that only trained and instructed personnel or specially trained personnel work on the pumps. This especially applies to assembly, connection and servicing work.</p> <p>Make sure that all personnel have read and understood the operating and installation instructions, and in particular the "Safety" chapter.</p>
Working in a safety-conscious manner	Observe the accident prevention and safety regulations when performing any work on the pump and during operation.
Handling dangerous media	When pumping dangerous media, observe the safety regulations for handling such media.
Notes	Always ensure adherence to all information stickers on the pumps, such as flow direction arrows and type plates, and keep stickers in legible condition.
Environmental protection	All replacement parts should be properly stored and disposed of in accordance with the applicable environmental protection regulations. Ensure adherence to the pertinent national and international regulations. This especially applies to parts contaminated with toxic substances.
Disposal	<p>Dispose of all packaging in an environmentally appropriate manner. The packaging materials are recyclable.</p> <p>Ensure that the pump is disposed of in an environmentally appropriate manner at the end of its useful life. Use appropriate waste collection systems for the disposal of end-of-life equipment. Used pumps contain valuable recyclable materials.</p>



EU directives/standards	<p>The pumps are in accordance with the requirements of the guidelines 2011/65/EU (ROHS2)</p> <p>The pump complies with all relevant provisions of the following directives: the EC machinery directive 2006/42/EC, safety provisions of the EC low-voltage directive 2006/95/EC and the EC directive on electromagnetic compatibility 2004/108/EC.</p> <p>The following harmonised standards are complied with: EN 61010-1 EN 61326-1</p>
Customer services and repairs	<p>All repairs to the pump(s) must be carried out by the relevant KNF Customer Service team.</p> <p>Only use KNF original parts for all maintenance work.</p>

## 4. Technical data

### 4.1. Pump materials

The type designation **KT** stands for:

Assembly	Material <sup>1)</sup>
Pump head	PP
Valve plate / seals	FFPM
Diaphragm	PTFE-coated
Housing	PA, TPE, PC

Tab. 2: *KT* <sup>1)</sup> according to DIN ISO 1629 and 1043.1

The type designation **TT** stands for:

Assembly	Material <sup>1)</sup>
Pump head	PVDF
Valve plate / seals	FFPM
Diaphragm	PTFE-coated
Housing	PA, TPE, PC

Tab. 3: *TT* <sup>1)</sup> according to DIN ISO 1629 and 1043.1

The type designation **FT** stands for:

Assembly	Material <sup>1)</sup>
Pump head	PTFE
Valve plate / seals	FFPM
Diaphragm	PTFE-coated
Housing	PA, TPE, PC

Tab. 4: *FT* <sup>1)</sup> according to DIN ISO 1629 and 1043.1

### 4.2. Hydraulic ratings

Type	Liquiport® 100	Liquiport® 1.100
Flow rate [l/min] <sup>1) 2)</sup>	0.2 – 1.3	0.2 - 1.3
Suction head [mWG]	3	3
Permissible pressure [bar g]	1.0	6.0
Permissible viscosity of medium [cSt]	150	150

Tab. 5: Hydraulic ratings for Liquiport® 100 / Liquiport® 1.100

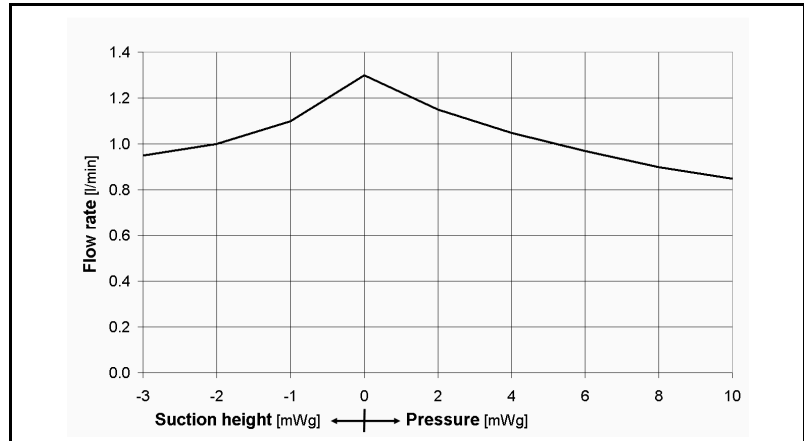

Fig. 1: Flow rate curve for Liquiport® 100

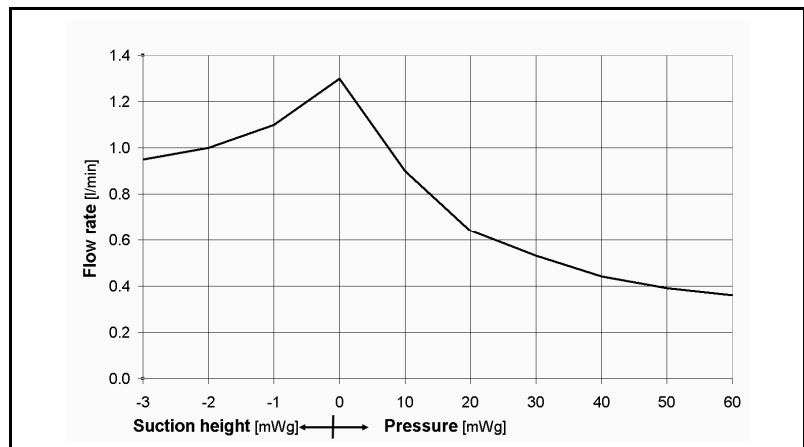

Fig. 2: Flow rate curve for Liquiport® 1.100

<sup>1)</sup> Measured with water at 20 °C

<sup>2)</sup> Flow rates may vary from the values shown, depending on fluid viscosity, pump head material and the hoses / hose connectors used.



Pump model	Liquipor <sup>®</sup> 300	Liquipor <sup>®</sup> 1.300
Flow rate [l/min] <sup>1) 2)</sup>	0.5 – 3.0	0.5 - 3.0
Suction head [mWG]	3	3
Permissible pressure [bar g]	1.0	6.0
Permissible viscosity of medium [cSt]	150	150

Tab. 6: Hydraulic ratings

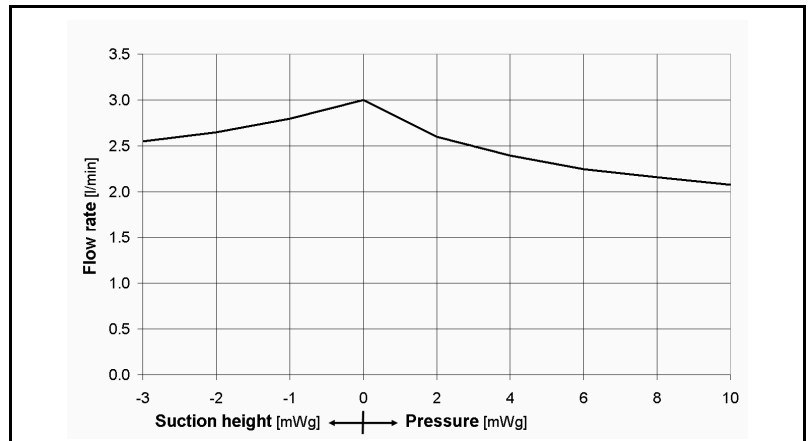
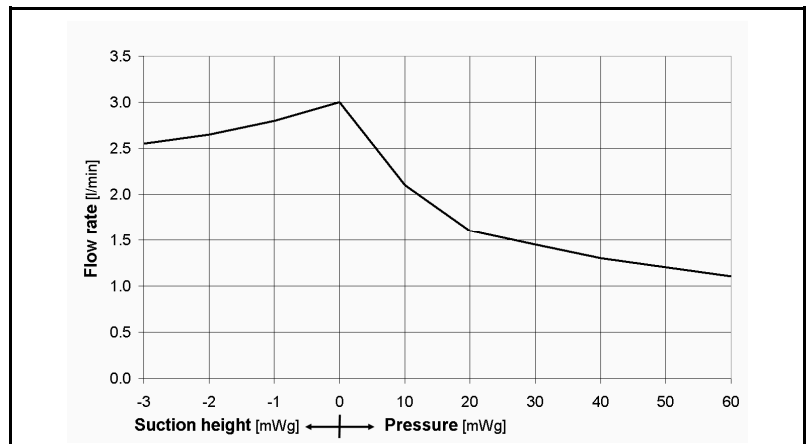
Fig. 3: Flow rate curve for Liquipor<sup>®</sup> 300Fig. 4: Flow rate curve for Liquipor<sup>®</sup> 1.300

### 4.3. Hydraulic connections

Pump model	Connection type
Liquipor <sup>®</sup> 100 Liquipor <sup>®</sup> 1.100	Internal thread NPT 1/8" with hose connector for hose ID 8mm
Liquipor <sup>®</sup> 300 Liquipor <sup>®</sup> 1.300	Internal thread NPT 1/8" with hose connector for hose ID 12mm

Tab. 7: Hydraulic connections

#### 4.4. Electrical Data

Pump model	Liquiport® 100	Liquiport® 1.100
Nominal mains voltage [V]	100 – 240V AC +/- 10%,	
Frequency [Hz]	50-60 Hz	
Max. power consumption AC 100 V / 115 V / 240 V [W]	12 / 12 / 12	15 / 15 / 16
Max. power consumption DC [W]	12	15
Pump DC voltage [V]	24 V DC	
Max. current consumption DC RMS 24 V [A]	0.5	0.63
Max. short-term peak current [A]	0.8	0.8
Power supply protection	Electronic overload protection	
Pump protection	Electronic overload protection	

Tab. 8: Electrical Data

Pump model	Liquiport® 300	Liquiport® 1.300
Nominal mains voltage [V]	100 – 240V AC +/- 10%,	
Frequency [Hz]	50-60 Hz	
Max. power consumption AC 100 V / 115 V / 240 V [W]	22 / 22 / 24	30 / 30 / 32
Max. power consumption DC [W]	22	29
Pump DC voltage [V]	24 V DC	
Max. current consumption DC RMS 24 V [A]	0.92	1.2
Max. short-term peak current [A]	1.3	1.3
Power supply protection	Electronic overload protection	
Pump protection	Electronic overload protection	

Tab. 9: Electrical Data

#### 4.5. Other parameters

Pump model	Liquiport® 100 Liquiport® 1.100	Liquiport® 300 Liquiport® 1.300
Weight of pump [kg] <sup>1)</sup>	1.0	1.5
Permissible ambient temperature [°C]	+5 to +40 °C	
Permitted medium temperature	+5 to +80 °C	
Rated speed [rpm]	3000 rpm	
Noise level [dBA]	< 40dBA	
Pump protection type	IP 65	
Power supply protection type	IP 40	
Protection class	III	

Tab. 10: Other parameters

<sup>1)</sup> The weight may differ slightly from the stated value, depending on the version.

#### 4.6. External actuation (RC version only)

Parameter	Value
<i>Analogue input</i>	
Signal range	0-10V
Signal range optional <sup>1)</sup>	0-20mA
Input resistance [ $\Omega$ ]	133 k $\Omega$ at 0-10V 510 $\Omega$ at 0-20mA
Electric strength [V] TTL	24 V DC
<i>Digital input</i>	
Signal range	Pull up at 24 V
Electric strength [V] TTL	24 V DC
Low level (ON)	< 0.8 V = low
High level (OFF)	> 2.0 V = high
Pull-up resistance	10 k $\Omega$
Resistance to ground	43 k $\Omega$
<i>Digital output</i>	
Electric strength open collector [V] TTL	24 V DC
Load capability open collector [mA] TTL	10mA

Tab. 11: External actuation

<sup>1)</sup> Optional on request.

- 1 Analogue input  
*Brown*
- 2 External actuation jumper  
*White*
- 3 Pulse input  
*Blue*
- 4 Open collector output  
*Black*
- 5 Ground  
*Grey*

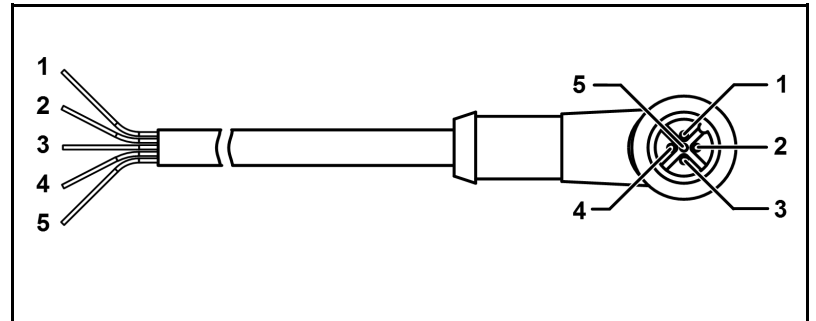

Fig. 5: RC cable pins

Pin No.	Wire colour	Description	Function
1	Brown	Analogue input	(0%) 15% to 100% flow rate
2	White	External actuation jumper	Switches pump over to external actuation. → Control knob is deactivated
3	Blue	Pulse input	Start/Stop via external actuation
4	Black	Open collector output	Operating mode output (On/Off)
5	Grey	Ground	--

Tab. 12: RC cable pins

## 5. Assembly and function

### 5.1. Design of the laboratory pump

- 1 On / Off button
- 2 Control knob
- 3 Flow rate display
- 4 Standby indicator
- 5 External indicator
- 6 Inlet
- 7 Pump head
- 8 Outlet
- 9 Power supply plug
- 10 External actuation plug (RC version only)

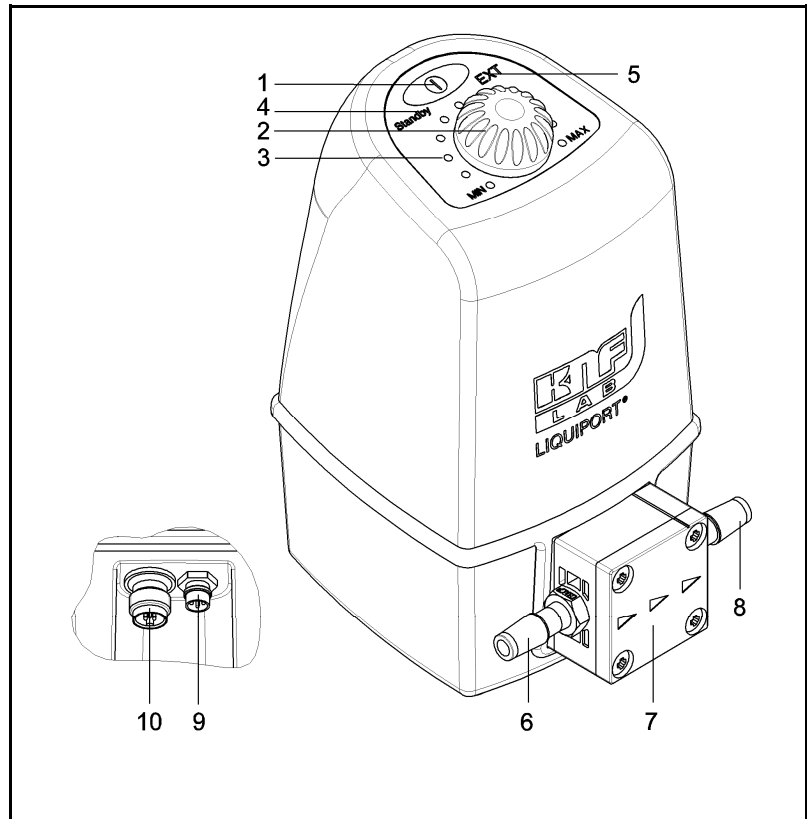

Fig. 6: Diaphragm pump

### 5.2. Operating principle

- 1 Exhaust valve
- 2 Inlet valve
- 3 Working chamber
- 4 Diaphragm
- 5 Eccentric
- 6 Connecting rod
- 7 Pump drive

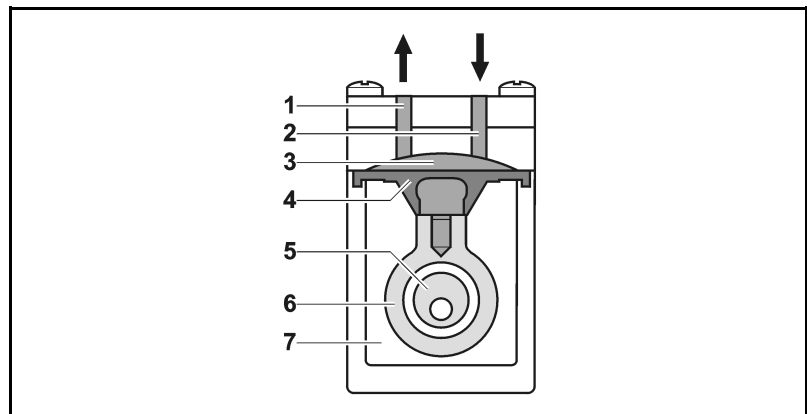

Fig. 7: Operating principle

Diaphragm liquid pumps are based on reciprocating displacement pump technology. An elastic diaphragm (4) is moved up and down by the eccentric (5) and the connecting rod (6). During the down stroke, the diaphragm sucks in the medium through the inlet valve (2). During the up stroke, it forces medium out of the pump head through the exhaust valve (1). The diaphragm hermetically seals off the working chamber (3) from the pump drive (7).

## 6. Installation and connection

All pumps must be installed only in accordance with the operating parameters and conditions described under Technical data (see Chapter 4).

Observe the safety notes (see Chapter 3).

### 6.1. Installation

➔ Before installation, store the pump at the installation location to bring it up to ambient temperature.

Dimensions ➔ Pump dimensions (see Fig. 8, Fig. 9)

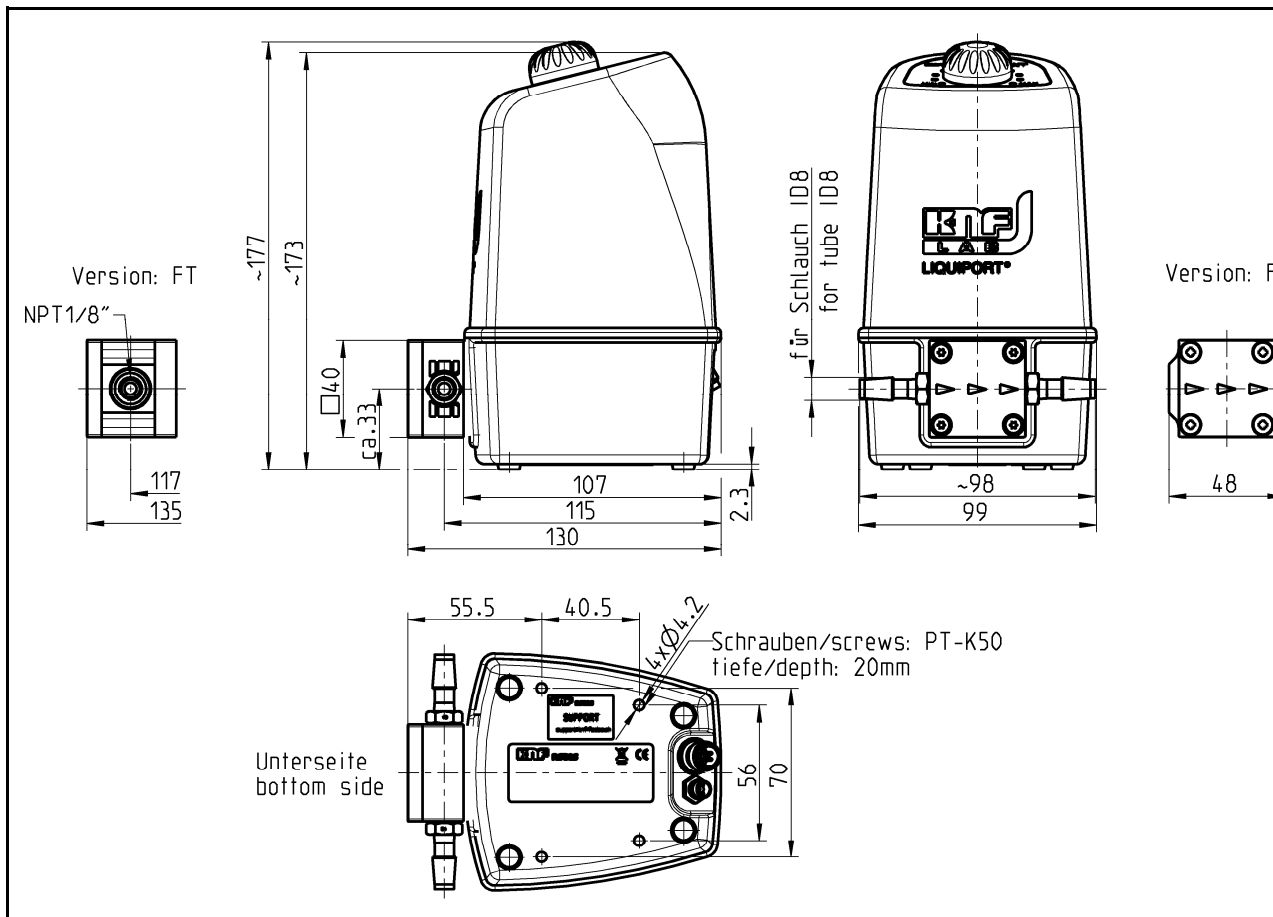

Fig. 8: Mounting dimensions for Liquiport® 100 / Liquiport® 1.100 (dimension tolerances as per DIN ISO 2768-1, tolerance class V)

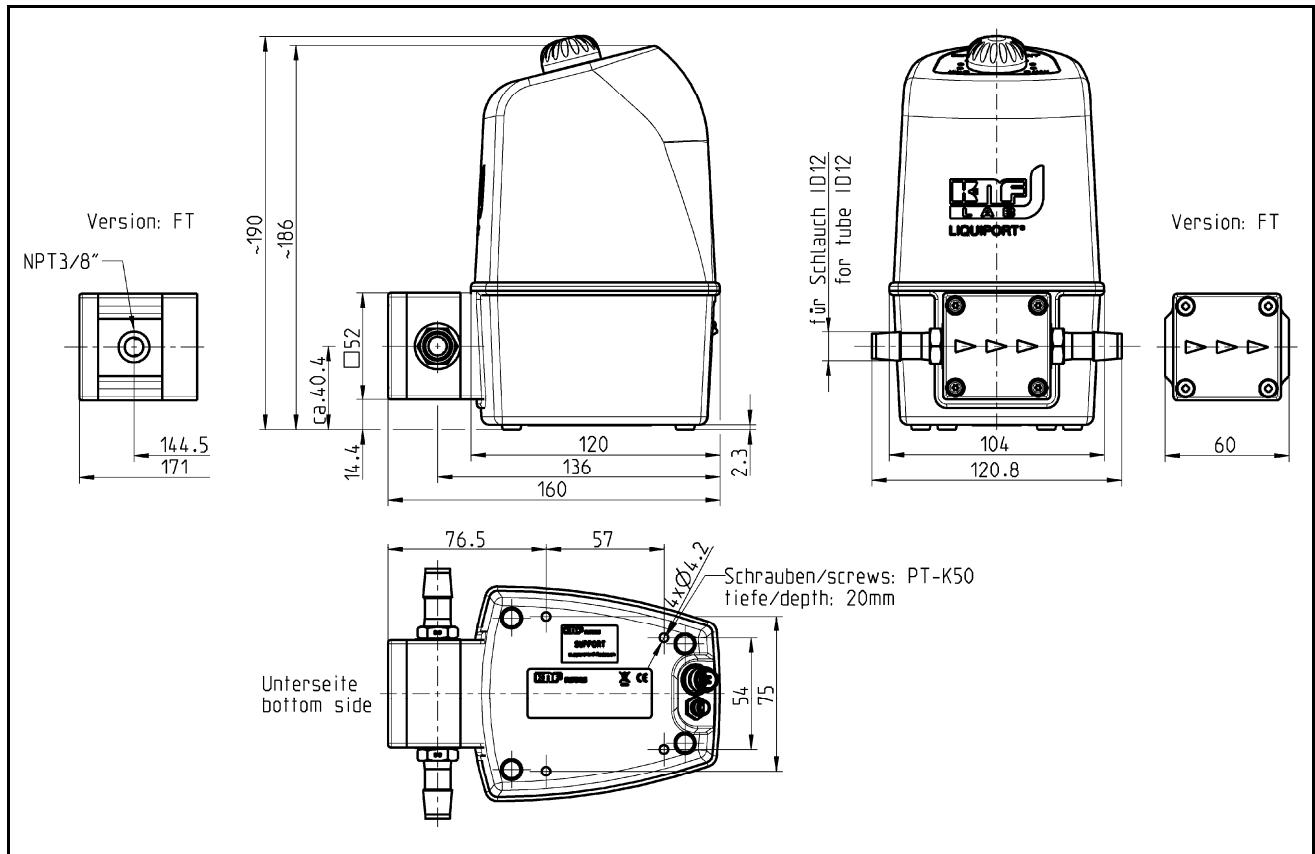

Fig. 9: Mounting dimensions for Liquiport® 300 / Liquiport® 1.300  
(dimension tolerances as per DIN ISO 2768-1, tolerance class V)

- Installation location
- ➔ Ensure that the installation location is dry, and protected from water in the form of rain, spray, splashes and drips.
  - ➔ Select a level surface that will provide a firm base for the pump.
  - ➔ When choosing the location, ensure that the hose connections can be fitted without strain on the hoses. Do not put the hoses under tension, and avoid bending and kinking.
  - ➔ Protect the pump from dust.
  - ➔ Protect the pump against vibration and impact.
- Mounting orientation
- The pump is primarily intended for upright operation. Other installation positions are also possible.
- ➔ Two additional mounting screws can be inserted from the bottom of the pump base (see Fig. 8, Fig. 9)

## 6.2. Electrical connection

- ➔ All electrical connection work must adhere to the pertinent norms, directives, regulations and technical standards.
1. Connect cable from mains plug to pump power supply socket
  2. Plug the mains plug into a correctly installed and properly earthed mains socket.

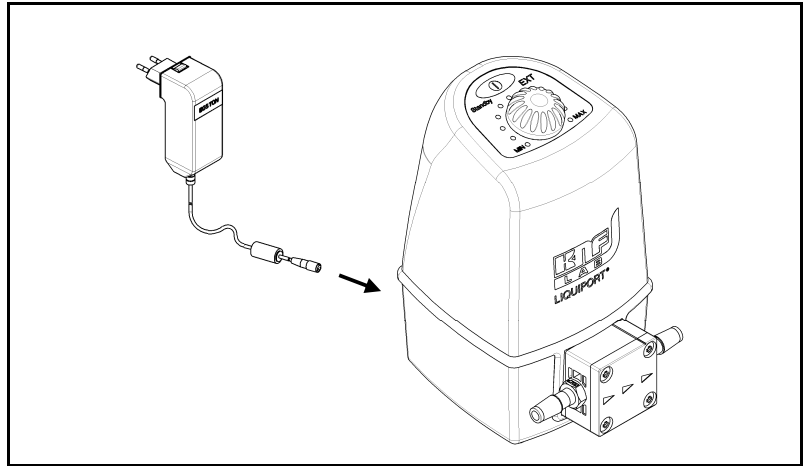

Fig. 10: Electrical connection

- i** The pump must be connected only to a correctly installed and properly earthed mains socket.
- i** Ensure that the mains plug is protected from water splashes.



**CAUTION**

Safety note

Always remove the mains plug from the socket before carrying out any work on the pump.



## 6.3. External drive (RC version)

RC cable

1. Fit suitable connector for control unit that is being used to external actuation cable (RC cable). For lead assignments see Chapter 4.6 Tab. 12 and Fig. 5.
  2. Remove protective cover from the RC plug.
  3. Connect the RC cable to the pump.
- i** Signals and load capacity (see Chapter 4.6).
  - i** RC functions (see Chapter 8).

## 6.4. Hydraulic connection

- |                                   |  |
|-----------------------------------|--|
| Connected components              | → Only connect components to the pump that are designed to handle the hydraulic data of the pump (see Chapter 4).  |
| Hoses                             | → Only use hoses that are suitable for the maximum operating pressure of the pump (see Chapter 4.2).<br>→ Only use hoses that are sufficiently chemically resistant to the liquids being pumped. |
| Customer-specific pumps (PL, PML) | → The connections described below apply to standard products. Different connections may apply for customer-specific projects (PML or PL).  |
- i** Arrows on the pump head indicate the flow direction.
- i** Keep the inlet line as short as possible in order to keep the priming process as brief as possible.

### Use of hose connectors

- 1 Hose
- 2 Connector
- 3 Hose bracket

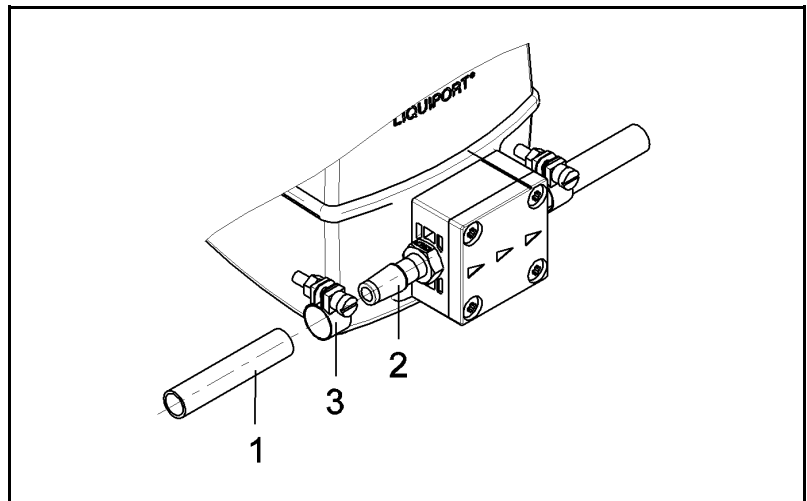

Fig. 11: Hose connector ID 8mm or ID 12mm

1. Remove protective caps from connections.
2. Cut off inlet and outlet lines (Liquiport® 100 and Liquiport® 1.100: hose ID8mm; Liquiport® 300 and Liquiport® 1.300: hose ID 12mm) straight with a sharp knife.
3. Push the hoses onto the connectors as far as they will go.
4. Secure hoses with suitable hose brackets for pressure applications with Liquiport® 1.100 or Liquiport® 1.300.
5. Check that the hoses and transition joints are fitted correctly and securely.
6. Check that the system is leak-tight.



- 1 Connector
- 2 Teflon sealing tape

### Use of internal thread NPT 1/8"

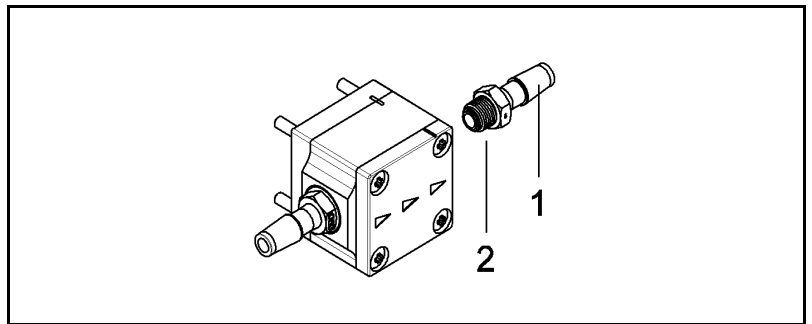

Fig. 12: Internal thread NPT 1/8"

1. Remove protective cap and screwed-in connectors from the connections.
2. Prepare required fitting with NPT 1/8" external thread with suitable sealant (e.g. Teflon sealing tape).
3. Screw in fitting and tighten

**i** Too much torque will damage the thread.

4. Check that the screw connection is fitted correctly and securely.
5. Check that the system is leak-tight.

## 6.5. Shutdown

➔ On completion of the pumping operation, flush the entire plant and the pump with a neutral fluid, then pump it empty.

**i** To ensure satisfactory start-up when the unit is again required, it is important to ensure that the pump is free of any crystallising, adhesive or curing media.

- ➔ Press the On/Off button to end the pumping operation
- ➔ Unplug the pump from the power supply.

## 6.6. Transport and interim storage

When packing the unit, ensure that the consignment will not be able to move within the packing.

Choose sufficiently robust packing so that the entire consignment will withstand unfavourable transport conditions.

- ➔ Use the original packaging.

## 7. Operation

### 7.1. Initial start-up

Before switching on the pump, check the following points:

Prerequisites for start-up
<ul style="list-style-type: none"> <li>▪ All hoses must be correctly attached.</li> <li>▪ Specifications of the power supply must correspond with the data on the pump and mains plug type plates.</li> <li>▪ The pump outlet must be clear of any obstruction.</li> <li>▪ All cables must be correctly connected.</li> </ul>

Tab. 13: Prerequisites for start-up

- Operate the pump only in accordance with the operating parameters and conditions described under Technical data (see Chapter 4).
  - Ensure the pump is being used for its intended purpose (see Chapter 2.1).
  - Avoid any improper use of the pump (see Chapter 2.2).
  - Observe the safety notes (see Chapter 3).
  - i** Blocked lines can lead to significantly higher pressures than the maximum permitted operating pressure with liquid diaphragm pumps, which can cause damage to the pump and/or to systems.
  - i** If excessive pressures like this are possible, appropriate protective measures must be provided such as a pressure relief valve or a pressure monitoring facility.  
Further information is available from your KNF adviser.
  - i** The pressure at the suction side of the pump must not be greater than the pressure at the outlet side.  
On the application of any higher pressures than this, the pump will allow the fluid to pass through in the pumping direction.  
This can be prevented by installing a pressure control valve<sup>1)</sup> at the outlet (pressure side) of the pump.
- <sup>1)</sup> E.g. an FDV30 pressure control valve from KNF Flodos
- i** The maximum permitted admission pressure at the suction side of the pump is 2 mWG (metres of water gauge).

- 1 On / Off button
- 2 Control knob
- 3 Flow rate display
- 4 Standby indicator
- 5 External indicator

## 7.2. Operating controls

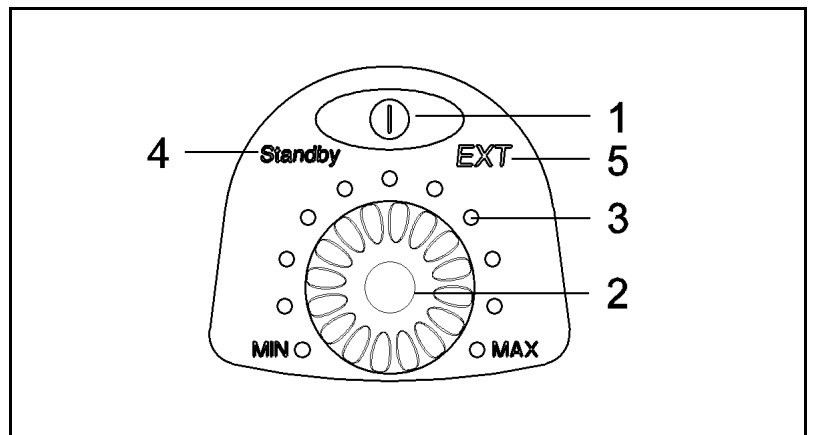

Fig. 13: Operating controls

## 7.3. Starting the pump

When it is connected to the power supply the pump is in standby mode by default, and the "Standby" indicator illuminates.

➔ Briefly press the "On/Off" button and the pump will start to transfer.

The "Standby" indicator goes off.

**i** An externally driven pump will start as soon as a valid control signal is present.  
(see Chapter 8).

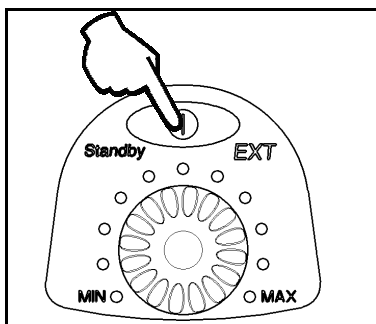

Fig. 14: Starting / stopping the pump

## 7.4. Stopping the pumping operation

➔ Briefly press the "On/Off" button and the pump will stop.

The "Standby" indicator goes on.

### 7.5. Adjusting the flow rate

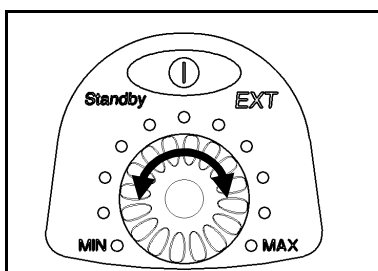

Fig. 15: Adjusting the flow rate

Set the pump to the required flow rate using the control knob.

The flow rate setting is shown by the flow rate indicator around the control knob.

Type	Flow rate [l/min]
Liquiport® 100	0.2 to 1.3
Liquiport® 1.100	0.2 to 1.3
Liquiport® 300	0.5 to 3.0
Liquiport® 1.300	0.5 to 3.0

Tab. 14: Specified flow

- i** If the analogue input is active, the "EXT" indicator illuminates and the control knob has no effect. The flow rate is then specified by the analogue input (see Chapter 8.1).
- i** The flow rate of the pump is reduced by counterpressure, suction head and higher medium viscosity.
- i** In the event of counterpressure, the pump will not start at low flow rate settings.

Reduce counterpressure or select a higher setting.

Operation in the event of counterpressure

In the event of counterpressure the pump cannot be set to the lower flow rates. The counterpressure must be reduced or a higher flow rate must be selected.

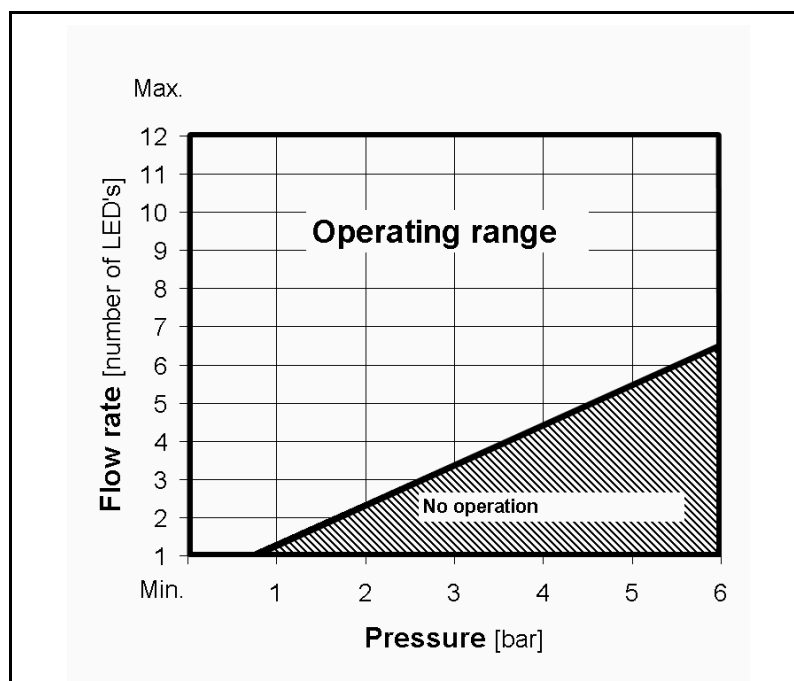

Fig. 16: Operating range

## 8. RC version – external actuation

**i** External actuation functions are available only in the RC version.

Connection details and technical data are provided in Chapters 4.6 and 6.3.

### 8.1. External actuation analogue input

The analogue input can be used to externally specify a pump flow rate from (0%) 15% to 100%.

Activating the analogue input

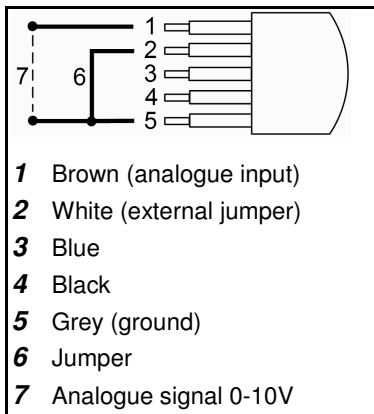

Fig. 17: RC cable jumper

The analogue input must be activated by connecting the RC cable.

➔ With RC cable connect white lead (jumper) to grey lead (ground) or with RC connector connect pin 2 to pin 5 (see Fig. 17).

➔ If external actuation is switched on, this is indicated at the pump by the illuminated "EXT" symbol (see Fig. 18).

**i** When the analogue input is active, the pump can be started only if a valid analogue signal is present.

**i** The control knob is deactivated. Manual flow rate entry is blocked.

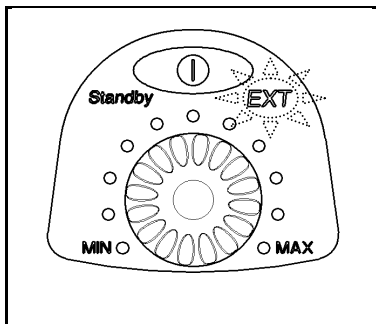

Fig. 18: "EXT" indication

### Control signals

Name	
Voltage range	0 – 10V
On threshold	$\geq 0.2V$
Off threshold	$\leq 0.2V$

Tab. 15: Analogue input signals

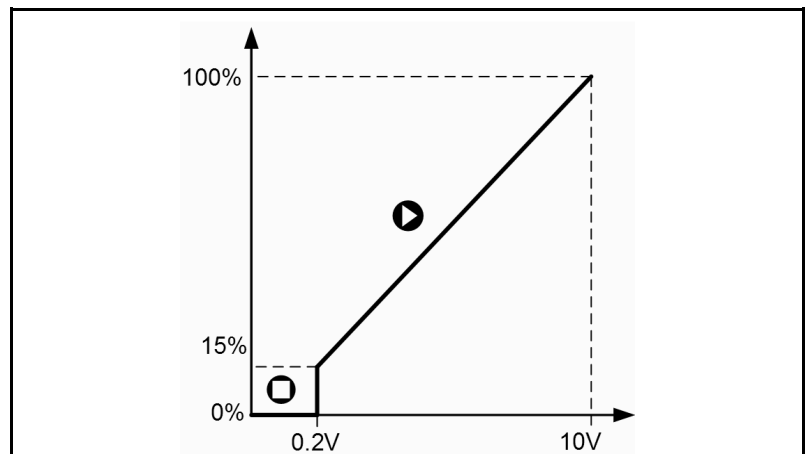

Fig. 19: Analogue input range

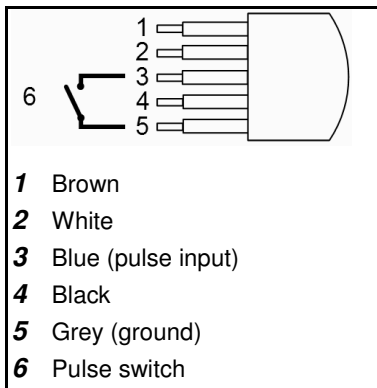

Fig. 20: Pulse input

### 8.2. Start/stop pulse input

The pump can be externally started and stopped via the pulse input.

- ➔ The falling signal edge at the pulse input triggers the starting or stopping of the pump.
- ➔ If analogue actuation is also used, a valid analogue signal must be present.

#### Control signals

Input	Meaning	Signal
Pulse	Start/Stop on signal pulse	Falling edge, less than 0.8V
Pulse duration	Maximum pulse duration	200 ms
Activation time	Minimum delay between activation pulse and deactivation pulse	300 ms
Deactivation time	Minimum delay between deactivation pulse and activation pulse	400 ms

Tab. 16: Signal pulse input

- i** Following a pulse, there must be a delay before a new pulse is sent (see Table 16).
- i** The pulse duration must not be longer than 200 ms.
- i** The use of debounced switches is recommended.

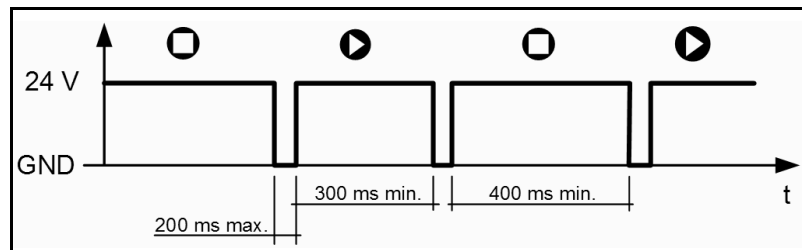

Fig. 21: Start/Stop pulse actuation

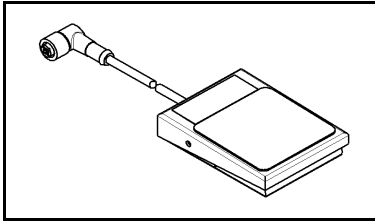

Fig. 22: Foot switch

### 8.3. Foot switch

With the RC version, the Liquiport® pulse foot switch (KNF Id. no. 155872) can be connected to the RC connector as an accessory.

- ➔ When the foot switch is operated, the pulse signal is connected to ground, which switches the pump on.
- ➔ If it is operated again the pump is switched off.

**i** The minimum switching times must be taken into consideration when the foot switch is operated (see chapter 8.2).

**i** The pump can also be switched on or off using the Start/Stop button at any time.

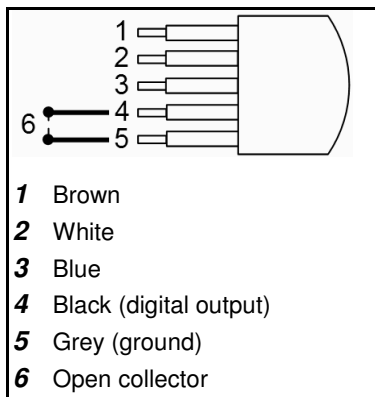

Fig. 23: Digital output

### 8.4. Digital output

The current operating status of the pump can be read out via the digital output.

The open collector is only switched on if the pump is transferring.

**i** The open collector output is internally connected to the collector of an NPN transistor (BC817-40) and to the internal 24V feed via a diode.

A maximum of 24V may be connected to the output.

The maximum current via the open collector must be limited to 10mA.

## 9. Servicing

### 9.1. Servicing schedule

Component	Servicing interval
Pump	- Regular inspection for external damage or leaks
Pump head	- Clean if the flow rate decreases, the pump does not work or no vacuum is created. - Replace parts if necessary (see Chapter 11).
Pump diaphragm	- Replace pump diaphragm if the pumping capacity decreases or a leak occurs - Replace pump diaphragm in the event of repeated head installation.
Intake filter □(accessory)	- Change if soiled.

Tab. 17: Servicing schedule

### 9.2. Cleaning

#### Flushing the pump

- If pumping aggressive media, KNF recommends flushing the pump with a neutral fluid under atmospheric conditions for a few minutes before switching off, to extend the service life of valves and diaphragm.

#### Cleaning the pump

- Wipe the outside of the pump with a soft dry cloth. Solvent should only be used for cleaning if the head materials and the pump housing are not affected (ensure that material is resistant).
- If there is compressed air available, blow off components.

#### Cleaning the pump head

- i** The pump head should only be cleaned if the pump is no longer working properly (no suction, inadequate flow rate or reverse suction of the pumped medium).  
Or of the pump head cannot be cleaned satisfactorily by flushing.
- Remove, clean and re-install pump head (see Chapter 9.3).



### 9.3. Cleaning/replacing valve plates and pump diaphragm

#### Prior requirements

- Pump must be switched off and mains plug removed from the socket.
- The pump must be free of any hazardous substances.
- Hoses must be disconnected from the pump head.

#### Tools and materials

Liquiport® 100 KT / TT, Liquiport® 1.100 KT / TT	
Qty.	Tools/materials
1	Torx T 20 screwdriver No. 2
1	Spare parts kit (see Chapter 11)
Liquiport® 100 FT, Liquiport® 1.100 FT	
Qty.	Tools/materials
1	Phillips screwdriver No. 2
1	Spare parts kit (see Chapter 11)
Liquiport® 300 KT / TT, Liquiport® 1.300 KT / TT	
Qty.	Tools/materials
1	T20 Torx screwdriver
1	Spare parts kit (see Chapter 11)
Liquiport® 300 FT, Liquiport® 1.300 FT	
Qty.	Tools/materials
1	Phillips screwdriver No. 2
1	Spare parts kit (see Chapter 11)

Tab. 18: Tools / materials

#### Information on procedure

- ➔ In order to provide optimum pump head tightness after opening the pump head it is advisable to replace the rolled diaphragm, the valve plates, the resonating diaphragm and the O-rings at the same time.



#### WARNING

Health hazard due to dangerous substances in the pump

Depending on the medium pumped, risk of caustic burns or poisoning.

- ➔ Use protective equipment if necessary, e.g. protective gloves, goggles.
- ➔ Flush pump with a neutral fluid and then pump empty.

**Dismantling the pump head**

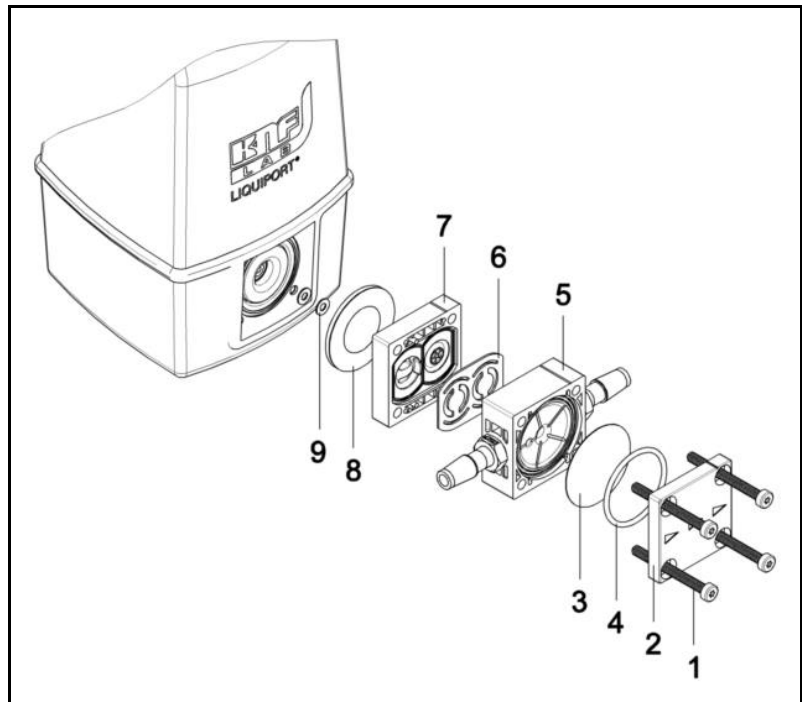

Fig. 24: Liquiport® 100

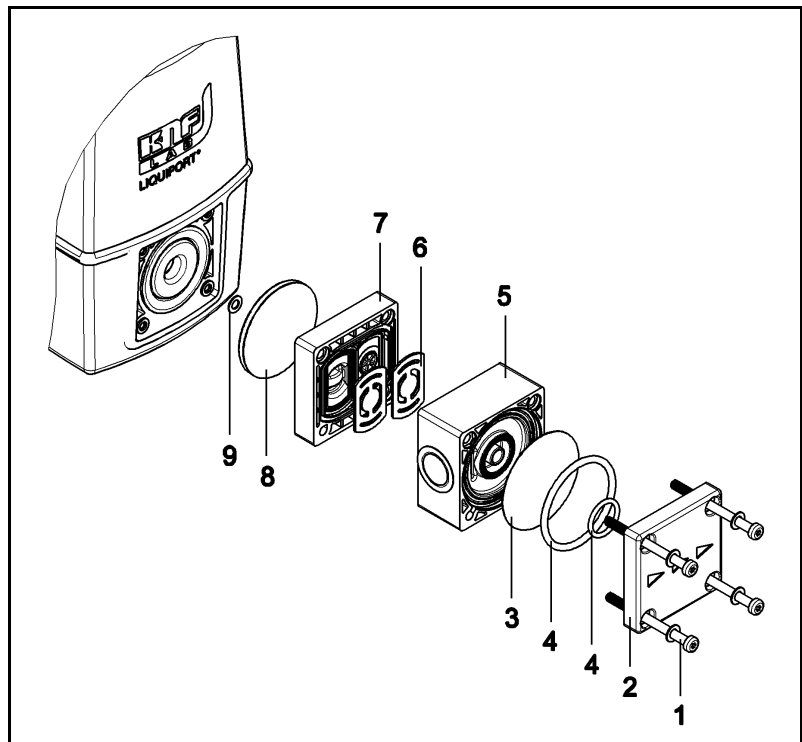

Fig. 25: Liquiport® 300

1. Loosen the four head screws (1) and remove the entire head.

**Removing the valves and seals**

2. Lift the connecting plate (5) from the intermediate plate (7).
3. Remove the valve plate (6) from the intermediate plate (7).
4. Remove the resonating diaphragm (3) from the connecting plate (5).
5. Remove the O-rings (4) from the cover plate.
6. Carefully grip the rolled diaphragm (8) and unscrew it by rotating anticlockwise. Remove the washers (9) and make sure that no washers 9 fall into the pump housing.

It is advisable to replace the rolled diaphragm (8).

**Cleaning the parts**

7. Clean rolled diaphragm (8), O-ring (4), resonating diaphragm (3), valve plate (6), intermediate plate (7) and connecting plate (5) with a cloth and then blow off with compressed air.

**Mounting the rolled diaphragm**

8. Slide the same number of washers (9) fitted between the diaphragm and the connecting rod over the connecting thread of the diaphragm (8). Make sure that no washer (9) falls into the pump housing.
9. Screw in the rolled diaphragm (8).
10. By lightly pressing on the rolled diaphragm push the ridge on the underside of the rolled diaphragm into the groove of the housing.

**Mounting the valve plates**

11. Place the dust-free valve plates (6) into the intermediate plate (7) in the correct position.

**Mounting the pump head**

12. Place the resonating diaphragm (3) into the connecting plate (5) and cover with the cover plate (2) fitted with the new O-ring.
13. All visible lines on the intermediate plate (7), the connecting plate (5) and the head plate (2) must be in line with each other.
14. Insert the four head screws (1) in the through holes of the pump head.
15. The head plate (2) must be positioned so that the flow direction arrows on the head plate coincide with the connections on the connecting plate (5).
16. Place the pump head onto the pump housing and tighten the four head screws (1) crosswise. Maximum torque is 1.5 Nm.

## 10. Troubleshooting

Information on procedure



**CAUTION**

Safety note

Always remove the mains plug from the socket before carrying out any work on the pump.



**WARNING**

Health hazard due to dangerous substances in the pump.

Depending on the medium pumped, risk of caustic burns or poisoning.

- Use protective equipment if necessary, e.g. protective gloves, goggles.
- Rinse the pump with a neutral liquid and pump empty.

→ Inspect the pump (see Tab. 19 and 20).

Pump does not work	
Cause	Fault remedy
Pump not connected to mains power supply.	→ Connect pump to mains supply.
No mains supply.	→ Check room fuse and switch on if necessary.
Connections or pipes are blocked.	→ Check pipes and connections. → Remove blockage.
External valve is closed or filter is blocked.	→ Check external valves and filters.
Worn diaphragm or valve plates / seals.	→ Replace diaphragm and valve plates/seals (see Chapter 9.3).
External actuation connected without a signal	→ Check external actuation signal.
Pump overload protection has tripped. - Flow rate indicator flashing - Standby indicator not illuminated	→ Pump unable to build up counterpressure. → Pump transferring against pressure that is too high. → Reduce pressure in system. → Reduce flow rate.
Pump overload protection has tripped. - Flow rate indicator flashing - The standby indicator illuminates	→ Pump unable to build up counterpressure. <sup>1)</sup> → Pump transferring against pressure that is too high. → Reduce pressure in system. → Reduce flow rate. → Restart the pump.

Tab. 19: Pump not transferring

<sup>1)</sup> Maximum pressure build-up depends on flow rate setting.

Please note: Pump not protected from overpressure.

<b>Low flow rate, pressure or vacuum</b>	
The pump does not achieve the performance stated in the Technical Data or on the data sheet.	
Cause	Fault remedy
Presence of positive pressure on the pressure side with simultaneous vacuum or positive pressure on the suction side.	➔ Change pressure conditions.
Cross-section of hydraulic lines or connectors too narrow or restricted.	➔ Disconnect the pump from the system and determine output values. ➔ Remove restriction (e.g. valve) if necessary. If applicable, use larger-diameter lines or connectors.
Leaks in connections, lines or pump head.	➔ Eliminate leaks.
Connections or lines completely or partially obstructed.	➔ Check pipes and connections. ➔ Remove any parts or particles causing blockages.
Soiled pump head components.	➔ Clean head components.
Worn diaphragm or valve plates/seals.	➔ Replace diaphragm and valve plates/seals (see Chapter 9.3).
Materials chemically damaged by pumped media.	➔ Select a type of material that is resistant and suitable.

Tab. 20: Low flow rate, pressure or vacuum

#### **Fault cannot be rectified**

If you are unable to identify any of the above causes, please send the pump to KNF customer services (see address on last page).

1. Flush the pump to clear the pump head of any hazardous or aggressive fluids (see Chapter 9.2).
2. Dismantle the pump.
3. Clean the pump (see Chapter 9.2).
4. Send the pump with completed decontamination declaration (see Chapter 12) to KNF customer services, stating the nature of the pumped medium.

## 11. Spare parts and accessories

### 11.1. Spare parts

Spare parts	Order No.
Liquipor <sup>®</sup> 100 spare parts kit, KT head	065262
Liquipor <sup>®</sup> 100 spare parts kit, TT head	065262
Liquipor <sup>®</sup> 100 spare parts kit, FT head	152631
Liquipor <sup>®</sup> 1.100 spare parts kit, KT head	065262
Liquipor <sup>®</sup> 1.100 spare parts kit, TT head	065262
Liquipor <sup>®</sup> 1.100 spare parts kit, FT head	152631
Liquipor <sup>®</sup> 300 spare parts kit, KT head	068691
Liquipor <sup>®</sup> 300 spare parts kit, TT head	068691
Liquipor <sup>®</sup> 300 spare parts kit, FT head	151902
Liquipor <sup>®</sup> 1.300 spare parts kit, KT head	069278
Liquipor <sup>®</sup> 1.300 spare parts kit, TT head	069278
Liquipor <sup>®</sup> 1.300 spare parts kit, FT head	151903

Tab. 21: Spare parts

### 11.2. Accessories

Connection nipples	Order No.
Screw-in nipple G NPT1/8" ID8 ETFE	153751
Screw-in nipple seal FFKM	155604
Screw-in nipple G NPT3/8" ID12 ETFE	153753
Screw-in nipple seal FFKM	155602

Tab. 22: Connection nipples

Foot switch	Order No.
Liquipor <sup>®</sup> pulse foot switch	155872

Tab. 23: Foot switch

Fasteners	Order No.
Tripod holder	160474
Mounting plate	160473

Tab. 24: Fasteners

## 12. Decontamination declaration

**i** KNF shall only undertake to repair the pump on condition that the customer provides certification of the transferred media and the cleaning of the pump (decontamination declaration).

→ Copy this page.

Enter the pump model, the Serial No. and the transferred media in the form below and send the signed form together with the flushed and cleaned pump to KNF customer services (see address on last page)

### Customer decontamination declaration for repair order

We confirm that the pump below has been used to pump the following media, and that the pump has been flushed and cleaned.

Pump model	
Serial No.	
Pumped media	

The pump does not contain aggressive, biological, radioactive, poisonous, or other dangerous media.

-----  
Company

-----  
Date/Signature