

## 87R-15B Oil Free Compressor



### Features

- 100% oil free
- 100% duty cycle
- Compact and easy to use
- Easy maintenance
- Long-life, 2-year warranty
- 10,000 hours cup life at 8bar

### Description

- 5µm air filtration
- Pressure regulator included
- Receiver with internal coating and 5-year warranty

### Accessories

- Automatic drain of the receiver
- Drain bottle



### Product Specifications

Model	87R-15B			
Voltage	V	1x230	1x230	1x120
Frequency	Hz	50	60	60
Motor	HP	0.5	0.5	0.5
	kW	0.37	0.37	0.37
Displacement	l/min	82	91	91
Air flow @ 8bar	l/min	28	34	34
	cfm	1	1.2	1.2
Max. pressure	bar	8	8	8
	psi	120	120	120
Max. current	A	2.5	2.8	5.7
Receiver volume	litres	4	4	4
	gallon	1.1	1.05	1.1
Weight	kg	19	18	18
	lbs	42	40	40
Noise level	dB(A)/1m	61	63	63
Duty cycle		100%	100%	100%

### Air flow / pressure curve

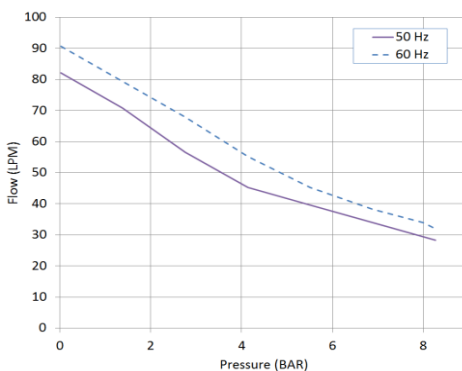

### Dimensions - mm [inches] \*

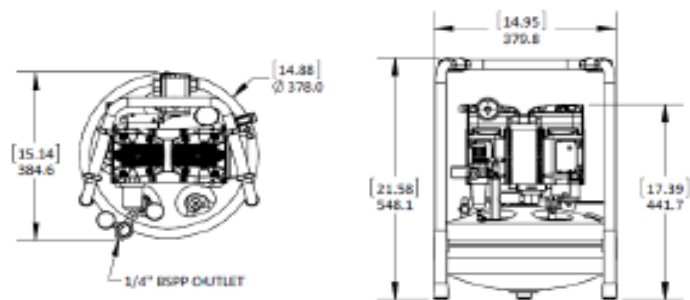



**Wolflabs**

# Wolf Laboratories Limited

[www.wolflabs.co.uk](http://www.wolflabs.co.uk)

Tel: 01759 301142

Fax:01759 301143

[sales@wolflabs.co.uk](mailto:sales@wolflabs.co.uk)



**Use the above details to contact us if this literature doesn't answer all your questions.**

**Pricing on any accessories shown can be found by keying the part number into the search box on our website.**

The specifications listed in this brochure are subject to change by the manufacturer and therefore cannot be guaranteed to be correct. If there are aspects of the specification that must be guaranteed, please provide these to our sales team so that details can be confirmed.

