

20000004637

# IKA®

RW47 digital\_032015

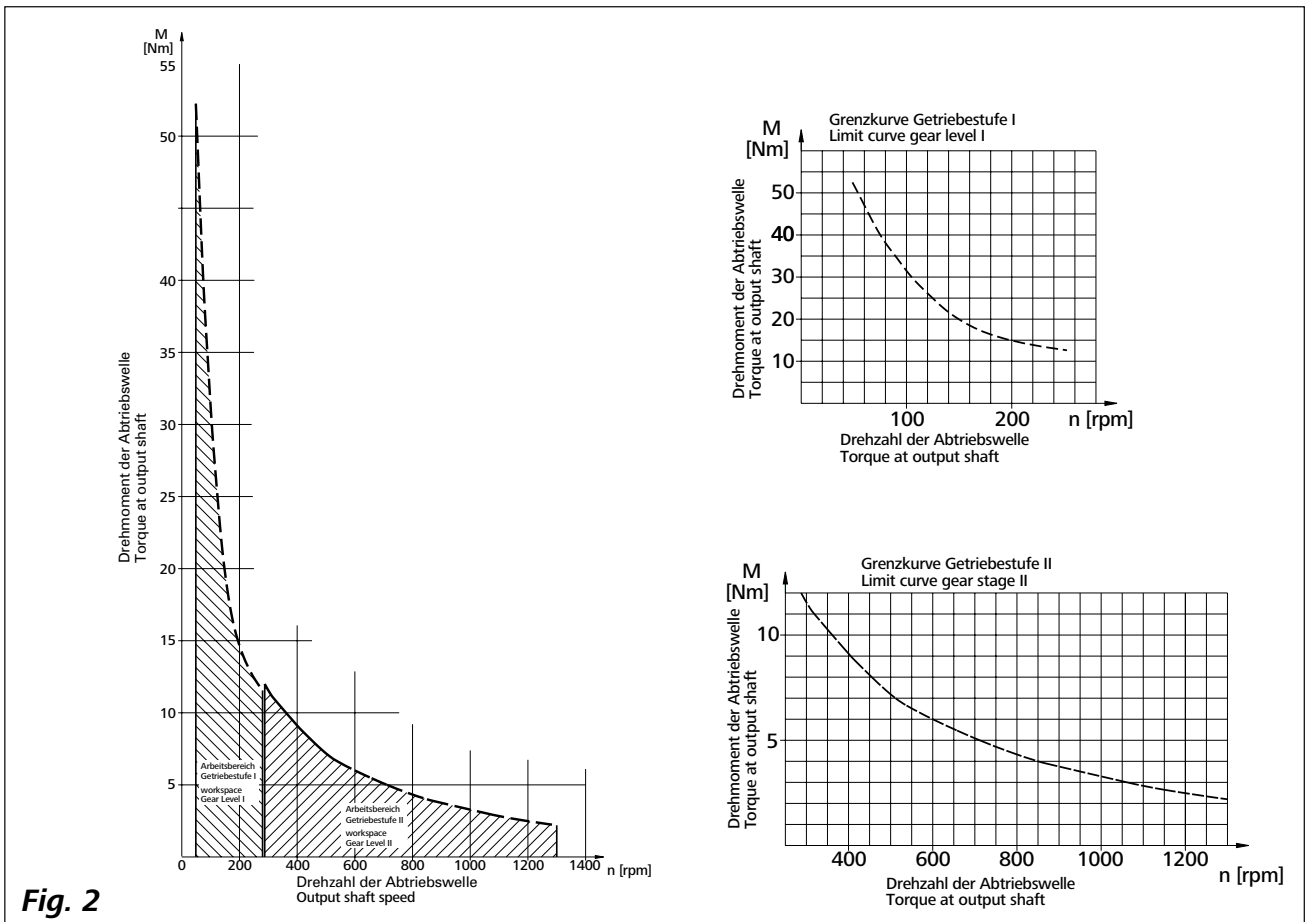
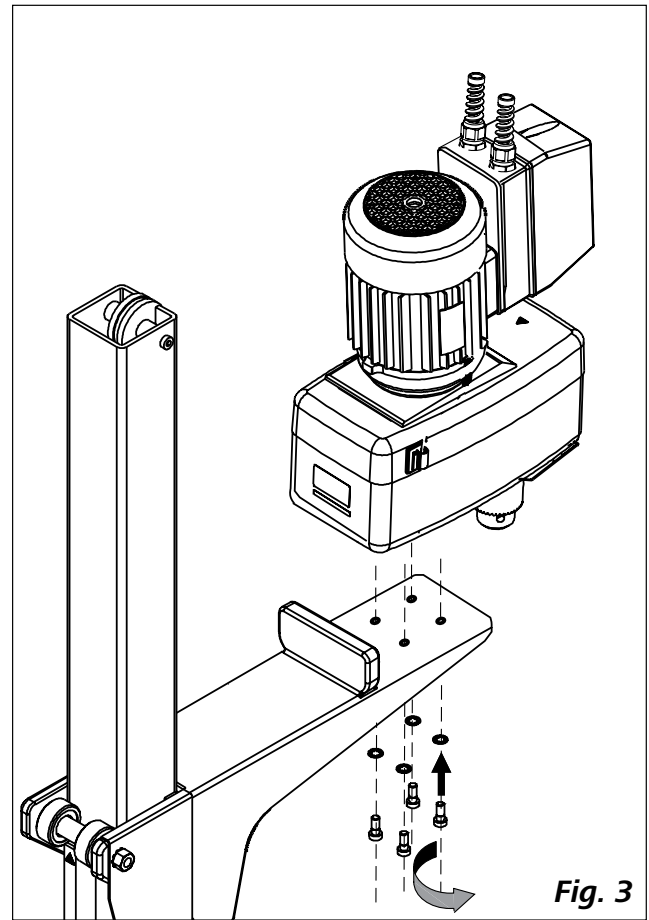
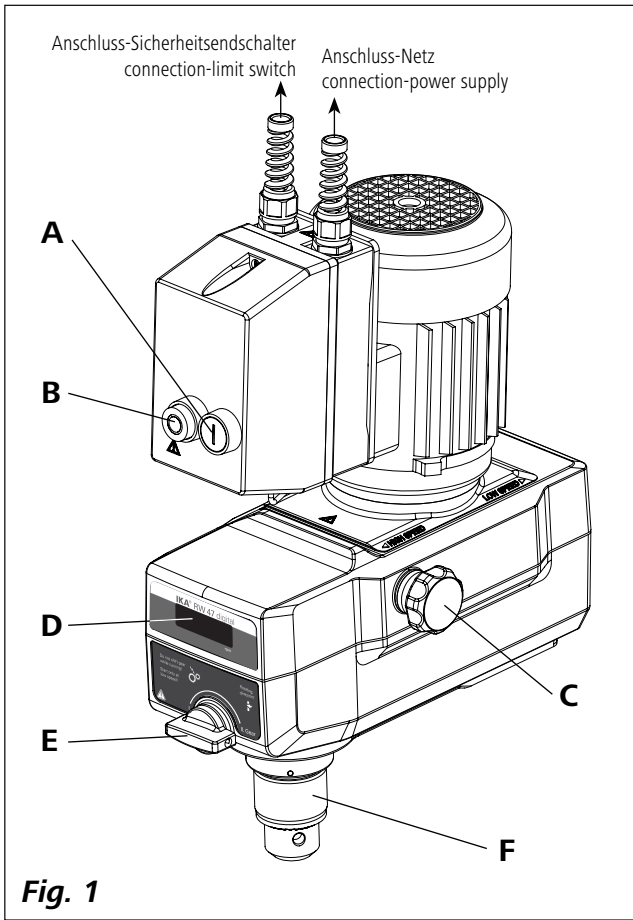
## IKA® RW 47 digital

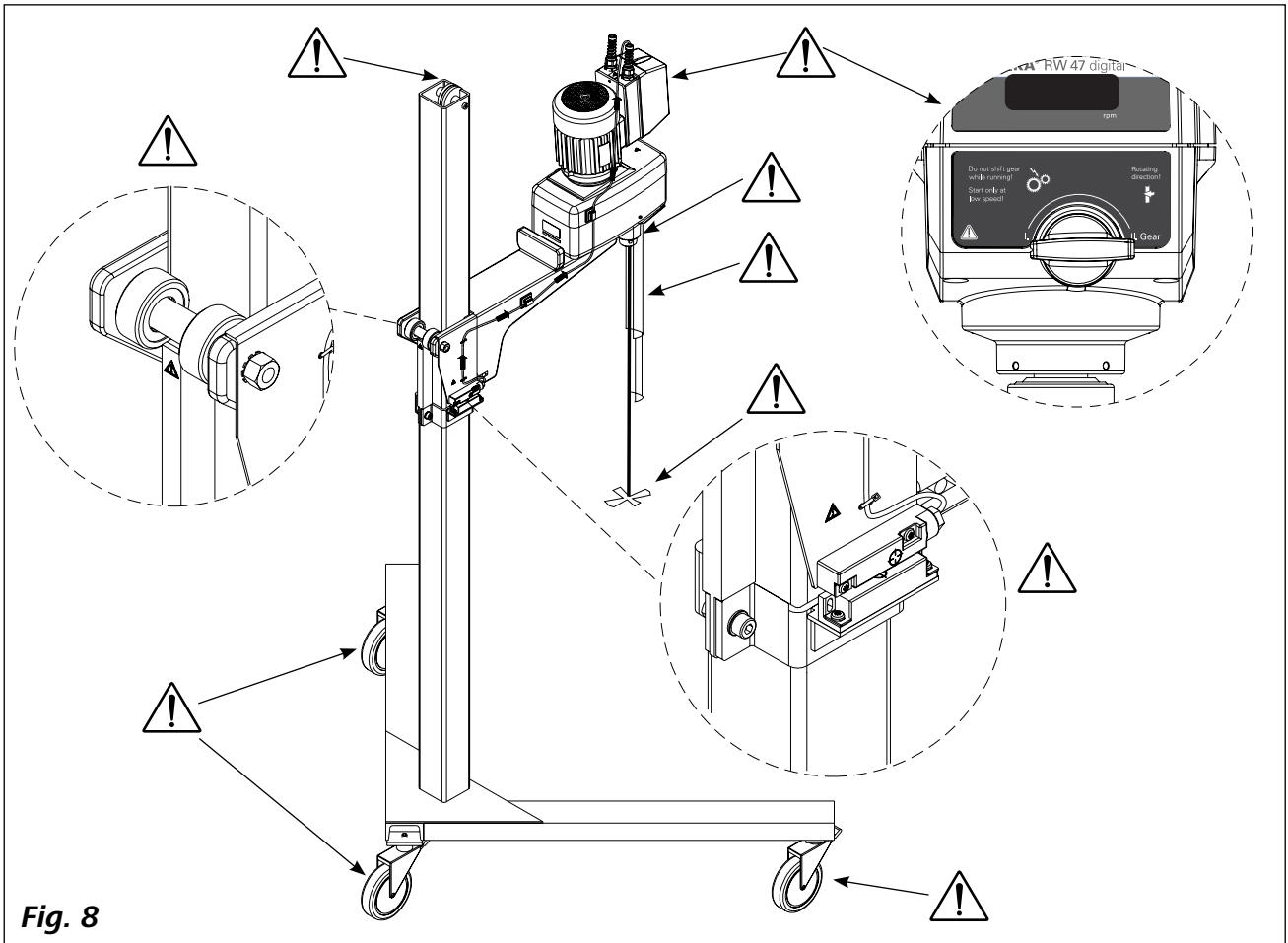
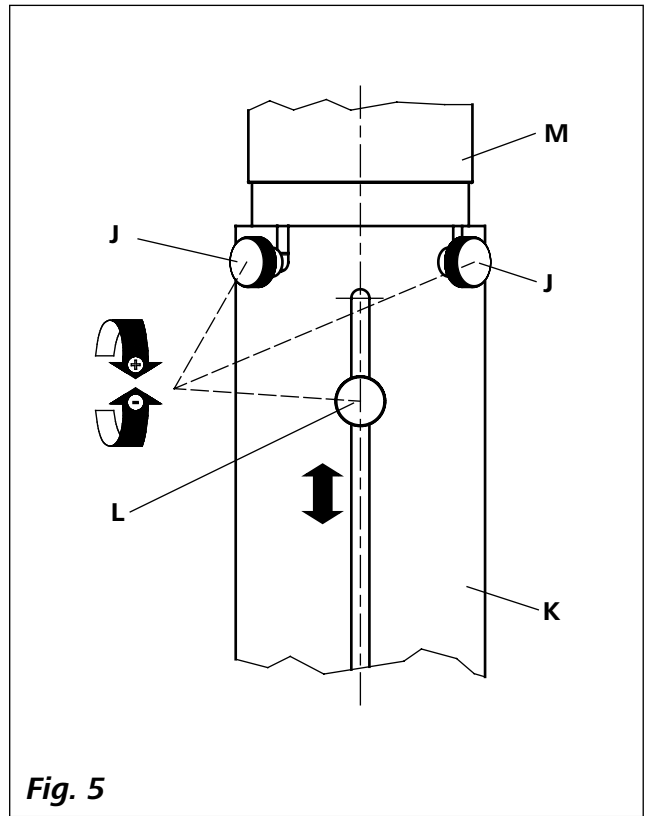
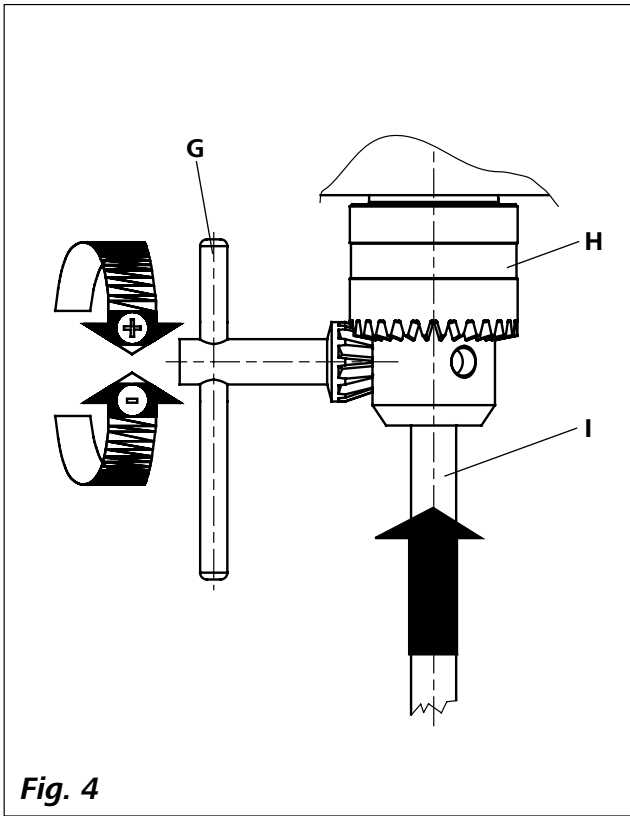


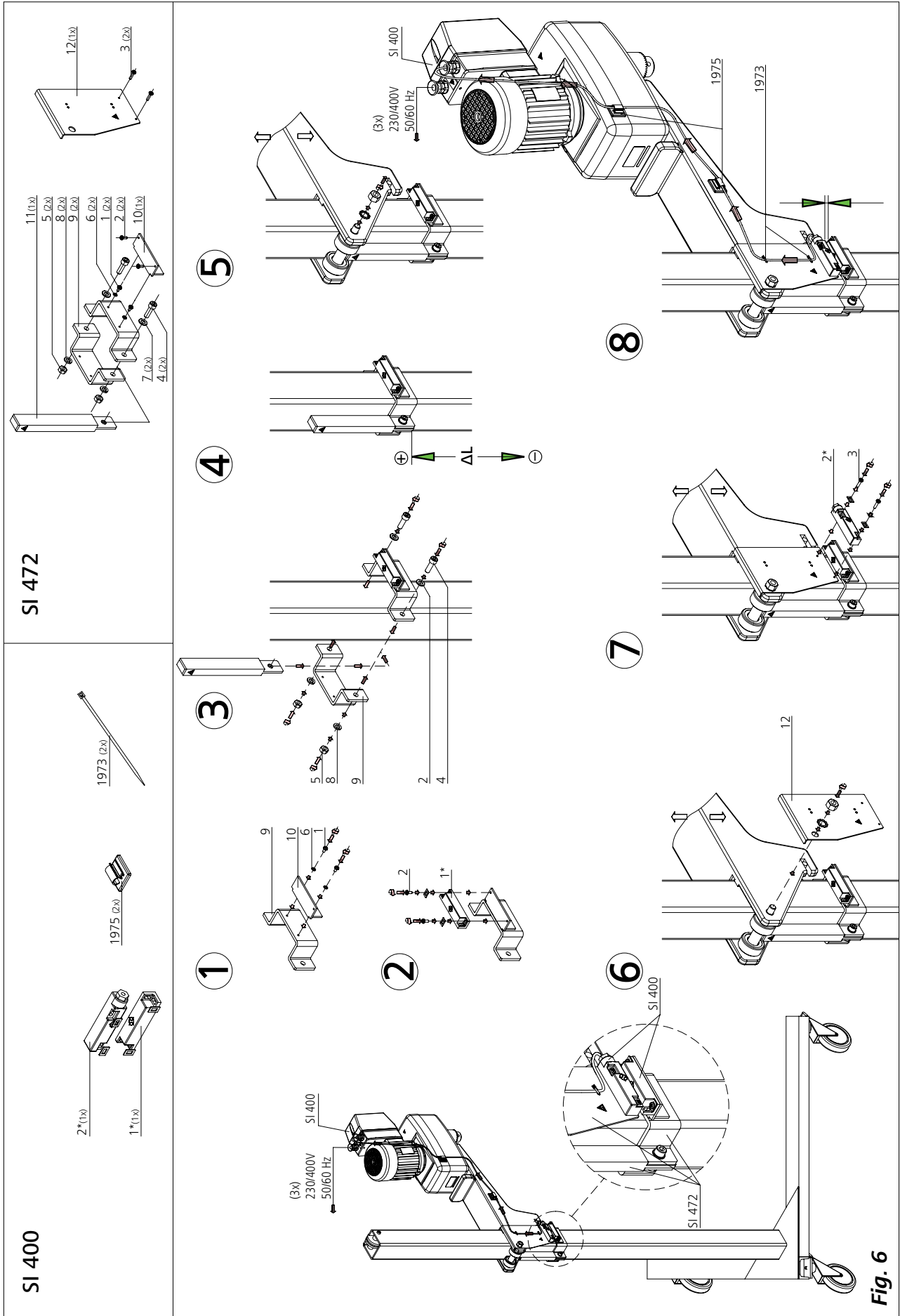
Operating instructions

EN



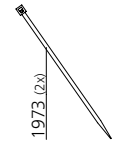
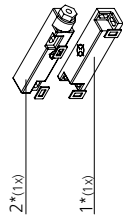




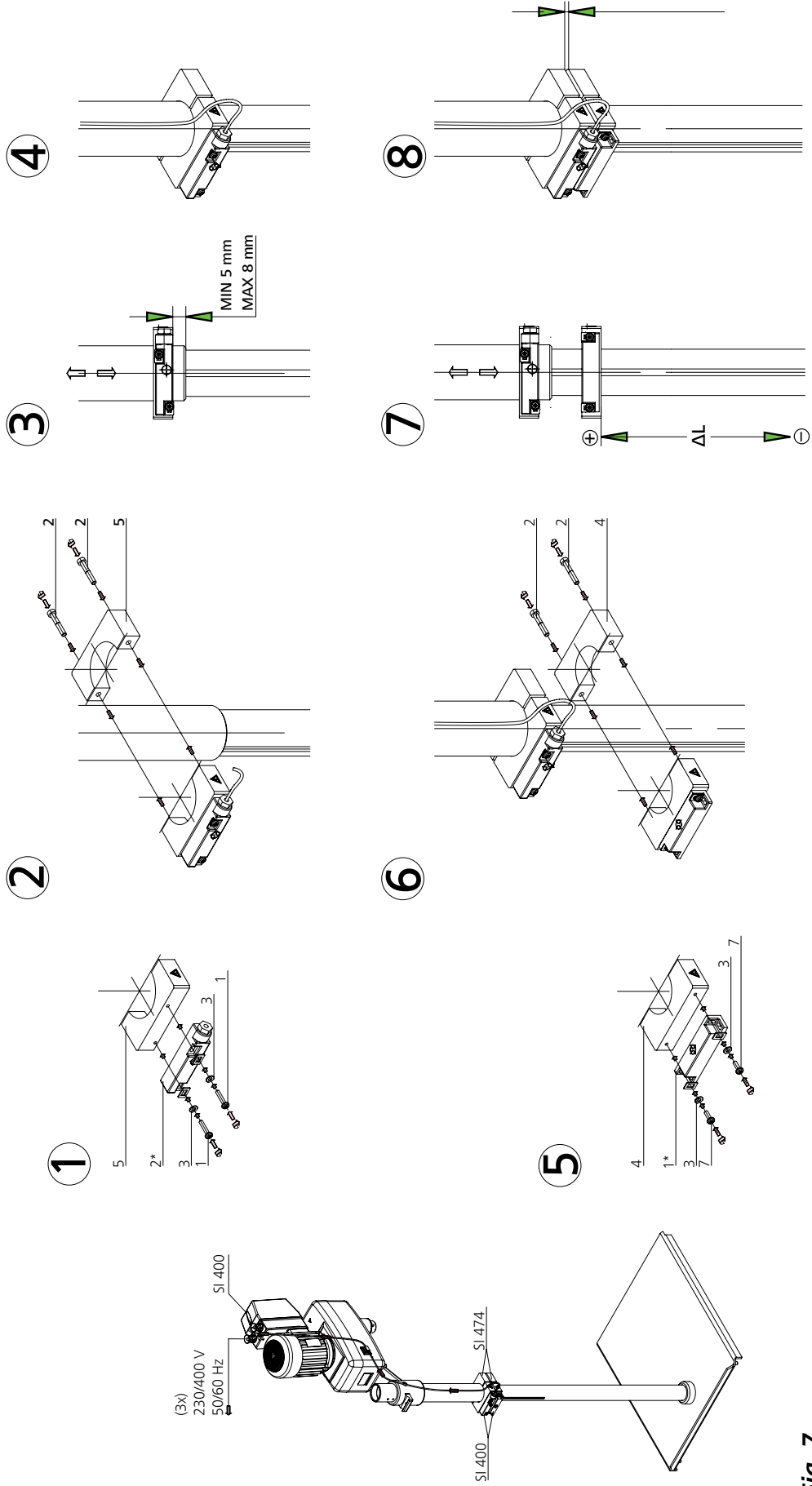
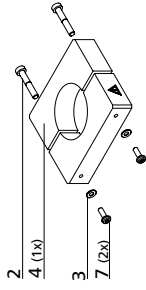
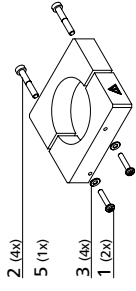


**Fig. 6**

SI 400



SI 474



## Contents

	Page
EC-Declaration of conformity	6
Explication of warning symbols	6
Safety instructions	7
Correct use	9
Unpacking	9
Useful information	9
Drive	9
Motor circuit breaker	10
Gear speed change	10
Output shaft	10
Speed display	10
Commissioning	10
Securing	11
Switching on the instrument	11
Maintenance and cleaning	12
Error codes	13
Warranty	13
Accessories	13
Permitted <b>IKA</b> ® stirrer tools	13
Technical data	14
Wiring diagram	15, 16

## EC-Declaration of conformity

We declare under our sole responsibility that this product corresponds to the regulations 2006/42/EC and 2004/108/EC and conforms with the standards or standardized documents: EN 61010-1, -2-051; EN 12 100-1, -2; EN 61326-1 and EN 60204-1.

## Explication of warning symbols



General hazard



This symbol identifies information **that is of vital importance for safeguarding your health and safety**. Disregarding this information can lead to health impairment and injuries.



This symbol identifies information **that is of importance for the technically correct functioning of the system**. Disregarding this information can result in damage to the instrument or to system components.



This symbol indicates information **which is important for ensuring that the operations of the instrument are performed efficiently and for using the instrument**. Failure to observe this information can result in inaccurate results.

## Safety instructions



- **Read the operating instructions in full before starting up and follow the safety instructions.**
- Keep the operating instructions in a place where it can be accessed by everyone.
- Ensure that only trained staff work with the instrument.
- Follow the safety instructions, guidelines, occupational health and safety and accident prevention regulations.
- Because the options for combining products, tools, stirring vessel, experiment and medium are nearly endless, user safety cannot be ensured simply with design requirements on the part of the product. For this reason, it may become necessary for users to take other precautionary safety measures. For example, glass devices or other stirring vessels that are sensitive to mechanical stress can be damaged or shattered by an imbalance, increasing the speed too quickly or too little distance between the stirring element and the stirring vessel. Users can suffer serious injury from glass breakage or from the freely rotating stirring element.
- Uncontrolled reactions can be triggered by mixing the heated material insufficiently or by the energy generated by selecting a speed that is too high. In case of these and other increased operational hazards, users must take additional appropriate safety precautions (e.g. shatter protection). In any case, when using critical or hazardous materials in your processes, **IKA®** recommends to use additional appropriate measures to ensure safety in the experiment. For example, users can implement measures that inhibit fire or explosions or comprehensive monitoring equipment. Furthermore, users must make sure that the OFF switch of the **IKA®** product can be accessed immediately, directly and without risk at any time, and above all, in case of fault.
- Do not operate the instrument in explosive atmospheres, with hazardous substances or under water.
- Process pathogenic materials only in closed vessels under a suitable fume hood. Please contact **IKA®** application support if you have any question.
- The instrument is not suitable for manual operation.
- The high torque developed by the **RW 47 digital** requires particular care in the choice of stand, cross sleeve and anti-rotation element for the agitating vessel.
- Set up the stand in a spacious area on an even, stable, clean, non-slip, dry and fireproof surface.
- You must ensure that the stirring element is securely clamped in the chuck!
- Use stirring shaft protective equipment and a safety cutout for height adjustable stands!
- The agitated vessels used for stirring have to be secured. Consider on a good stability of the entire structure.



Please pay attention to the dangerous parts of the equipment in **Fig. 8**.



If installation or positioning cannot ensure this access at all times, an additional **EMERGENCY STOP** switch that can be easily accessed must be installed in the work area.

- Only process media that will not react dangerously to the extra energy produced through processing. This also applies to any extra energy produced in other ways, e.g. through light irradiation.
- Protect the instrument and accessories from bumping and impacting.
- Check the instrument and accessories beforehand for damage each time when you use them. Do not use damaged components.
- Safe operation is only guaranteed with the accessories described in the "**Accessories**" section.
- Always switch the main switch in the OFF position or disconnect the power before changing stirring element and fitting allowed accessories.
- The instrument can only be disconnected from the mains supply by pulling out the mains plug or the connector plug.
- The socket for the mains cord must be easily accessible.
- Socket must be earthed (protective ground contact).
- The voltage stated on the type plate must correspond to the mains voltage.
- Please observe the permitted speed for the stirring element. Never set higher speed.
- Make certain that the unit is set at the lowest speed before commissioning; otherwise, the unit will begin running at the speed set in last operation. Gradually increase the speed.
- Pay attention when setting the speed to any imbalance of the stirrer tools and possible spraying of the medium to be stirred.



Never operate the instrument with the stirrer tools rotating freely. Ensure that parts of the body, hair, jewelry or items of clothing cannot be trapped by the rotating parts.



Wear your personal protective equipment in accordance with the hazard category of the medium to be processed; otherwise there is a risk of:

- splashing of liquids
- projectile parts
- body parts, hair, clothing and jewelry getting caught.



Beware of the risk of

- flammable materials
- glass breakage as a result of mechanical shaking power.



Reduce the speed if:

- the medium splashes out of the vessel because the speed is too high
- the instrument is not running smoothly
- the instrument begins to move around because of dynamic forces
- malfunction.



**Do not touch rotating parts during operation!**

- There may be electrostatic activity between the medium and the output shaft which could cause a direct danger.
- After an interruption in the power supply or a mechanical interruption during a stirring process, the unit does not restart automatically.
- It is important to note that the surfaces of the motor (cooling fins) and certain parts of the bearing may get very hot during operation.
- Never cover the ventilation slots or cooling fins on the motor as these are needed for cooling the drive system.
- Avoid knocking and impacting on the lower end of the shaft and the chuck gear teeth. Even minor, invisible damage can lead to imbalance and uneven shaft action.
- Ensure that the stand does not start to move.
- Imbalance of the output shaft, the chuck and in particular the stirring tools can lead to uncontrolled resonant vibrational behavior of the instrument and the whole assembly. Glass de-

vices and stirrer containers can be damaged or shattered by this. It can cause injury to the operator, also can damage the rotating stirring tool. In this case exchange the stirring tool for one without imbalance or remedy the cause of the imbalance. If there is still imbalance, return it to the dealer or the manufacturer along with a description of the fault.

- If the instrument is operated too long in overload or if the ambient temperature is too high, the instrument switches off permanently.
- The machine must only be opened by trained specialists, even during repair. The instrument must be unplugged from the power supply before opening. Live parts inside the instrument may still be live for some time after unplugging from the power supply.



Covering or parts that are capable of being removed from the unit without accessory equipment have to be reattached to the unit for safe operation in order to prevent, for example, the ingress of fluids, foreign matter, etc..



The unit must be switched off (motor standstill) before changing to another gear speed, otherwise the toothed gears in the reduction stage will be damaged.



The equipment must be wired by a qualified technician, otherwise there is a risk of electric shock!

- Before commissioning, the correct direction of rotation of the motor must always be ensured (test run without stirring tool: motor rotation as indicated of the arrow on the front foil, clockwise rotation, looking down on motor). The wrong direction of rotation can lead to the stirring tool coming off the shaft.
- If the unit is operated in different locations with a 5-pin plug, the direction of rotation must be checked before each commissioning, with no stirring tool fitted.
- Ensure that the loose parts cannot get in contact with the turning chucks and/or the stirring elements.
- The equipment can be run only when the supplied 4 M8 screws are fixed at the bottom of the device with respective thickness of the carrier plate.



## Correct use

- **Use**

For mixing/stirring liquids with low to high viscosity by using various stirring tools.

Intended use: Stand device (Chuck downward).

- **Range of use (indoor use only)**

- Laboratories
- Technical colleges
- Pharmacies
- Small-scale production

This equipment is suitable for use in all areas except:

- Residential areas
- Areas that are connected directly to low-voltage supply network that also supplies residential areas.

The safety of the user cannot be guaranteed:

- If the instrument is operated with accessories that are not supplied or recommended by the manufacturer
- If the instrument is operated improperly contrary to the manufacturer's specifications
- If the instrument or the printed circuit board are modified by third parties.

## Unpacking

- **Unpacking**

- Please unpack the device carefully
- In the case of any damage a detailed report must be sent immediately (post, rail or forwarder).

- **Delivery scope**

- an **RW 47 digital** overhead stirrer
- an operating instructions
- four hexagonal socket screws
- a hexagon socket offset screw key
- a chuck key
- a warranty card.

## Useful information

You can set speed from 57 to 1300 rpm with the 50 Hz (mains frequency) and speed from 69 to 1560 rpm with the 60 Hz (mains frequency). The unit may heat up during use. The ample cooling surfaces on the motor serve to distribute and radiate the heat as evenly as possible.

You can also use large mixing vessels together with **IKA®** stands without any problem.

The unit comes without a connection cable because the user's installation means that it is not possible to issue a standard length cable due to the different sizes of premises. Experts can determine the pin assignment from the wiring plan.

The output shaft is not designed as a hollow shaft and allows inserting the stirring element until it stops. It is important to ensure that the stirrer shank is securely clamped in the chuck.

## Drive

The motor can be infinitely adjusted via a friction wheel drive unit but is operated in one position only. The power output, rotational speed and torque of the motor are regarded as constant and are optimized for this operating position. After the friction wheel drive the motor power output is transmitted to the output shaft of the stirrer via either the first or second stage of the subsequent manually adjustable toothed gear train.

Neglecting all losses, the power at the output shaft during power transmission (conversion) is always as great as the power output of the motor. The gear train merely provides rpm and torque conversion, which can be described in purely theoretical terms by the characteristic curve plotted in **Fig. 2**.

Friction wheel wear is kept low by a helical clutch matched to the gear train. The down-pressure required at the friction wheel is adjusted by the helical clutch according to the moment acting on the stirrer shaft. A low torque results in a low down-pressure; a high torque results in a high down pressure.

## Motor circuit breaker

The ball race three-phase motor is maintenance-free. Its attached switching unit features a special safety device for operation in the case of over-current and under-voltage (under-voltage release) to permanently disconnect the motor and avoid thermal damage. The instrument can only be started up again by activating the ON switch (A, see **Fig. 1**), when power permitted for the motor is supplied.

You can find the basic connection and rating for the motor on its rating plate.

The safety switch **SI 400** can also be connected to the motor switching unit. When used in combination with an **IKA®** stand, this allows the user to switch on the instrument only at a defined height in the stand's working range.

If the stirring unit is operated in such a way that the instrument's **OFF** switch (B, see **Fig. 1**) is not accessible, you must add another **EMERGENCY STOP** switch to the work area so that it can be easily reached.

## Gear speed change

You can select one between two gear positions (**I** and **II**) using the toggle button (E, see **Fig. 1**) on the front of the instrument. You can only switch to a different cog wheel gear level when the instrument is switched off (motor stopped).

Otherwise this may cause damage to the gear cogs. The arrow on the front foil indicates the direction of the chuck.



**Only change the gear position at standstill!**

## Output shaft

The clamping chuck and output shaft permit clamping **IKA®** recommend stirrer tools (see "**Permitted IKA® Stirrer tools**" section).

The output shaft is not designed as a hollow shaft.



**Please see section "Safety instructions"!**

## Speed display

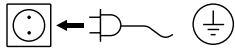
The rotation speed is adjusted by means of the rotary knob (C, see **Fig. 1**) on the side of the overhead stirrer.

The rotation speed is displayed directly in revolutions per minute (rpm) on the display (D, see **Fig. 1**).

## Commissioning

The overhead stirrer **RW 47 digital** must be secured to a stable stand (e.g. **R 474** or **R 472**) with four screws and wired according to the wiring diagram for proper use. The stirring vessel must always be well secured for safety reasons. You must also ensure that the mounting equipment (e.g. floor stand, telescope stand) is set up in such a way that it is not liable to topple and does not start to move during the stirring procedure. Accessories must be assembled and wired according to the assembly instructions (**Fig. 3** to **Fig. 7**).

If the stirring unit is operated in such a way that the instrument's **OFF** switch (B, see **Fig. 1**) is not accessible, you must add an another **EMERGENCY STOP** switch to the work area so that it can be easily reached.



If above conditions are met, the instrument is ready for operation after plugging in the mains plug.

Points of particular danger (such as crushing, rotating parts, clamping screws for stand legs and rollers etc.) are marked in **Fig. 8** with an exclamation mark. Please pay particular attention to these danger points during operation!

## Securing

### Securing the overhead stirrer to the stand

Diagram (see Fig. 3)

Place **RW 47 digital** overhead stirrer on the arm of the stand. Fasten the overhead stirrer to the stand from below with hexagonal socket screws supplied. The help of an assistant is needed for screwing on the overhead stirrer. The cable clips included in the delivery package are required for fixing the power cable of the unit (see **Fig. 6** and **Fig. 7**).

Check that the stirrer is held in position firmly prior to each use and also at regular intervals. The position of the stirrer must only be adjusted when the equipment is stationary and the power supply is disconnected.

### Securing the stirring element using the chuck

Diagram (see Fig. 4)

Slide the stirring element (I) into the chuck (H). Tighten the chuck firmly using the chuck key (G). The stirring tool must only be changed when the equipment is stationary and the power supply is disconnected.

### Securing the stirring shaft protector

Diagram (see Fig. 5)

You must use stirring shaft protector (K), e.g. **R 301**, when working to prevent injury. Use the bolts (J) to attach the plastic half-shell pieces to the stirrer (M), as shown in **Fig. 5**. The screw (L) can be used to adjust the length of the stirring shaft protector.

Check that the stirring shaft protector is held in position securely prior to each use and also at regular intervals. The position of the stirring shaft protector must only be adjusted when the equipment is stationary and the power supply is disconnected.

### Securing the safety switch to R 472 floor stand

Diagram (see Fig. 6)

**There is a danger of trapping between the safety limit switch, switch contacts and the end stop!**

Secure the safety switch **SI 400** safety switch to the support rod of **R 472** floor stand via fixing device **SI 472**. For this, follow the assembly instructions for "Safety switch" in the **Fig. 6**.

### Securing the safety switch to R 474 telescopic stand

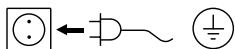
Diagram (see Fig. 7)

**There is a danger of trapping between the safety limit switch, switch contacts and the end stop!**

Mount the safety switch **SI 400** safety switch to the support rod of **R 474** telescopic stand via fixing device **SI 474**. For this, follow the assembly instructions for "Safety switch" in the **Fig. 7**.

## Switching on the instrument

Check whether the voltage given on the type plate corresponds to the available mains voltage.



The socket used must be earthed (fitted with earth contact).

If these conditions have been met, the machine is ready to operate when the mains plug is plugged in. If these conditions are not met, safe operation is not guaranteed and the machine could be damaged. When working with safety switch **SI 400**, the instrument only starts up once it has been set to the designated working height and the switch contact activates the safety switch.

During commissioning of the machine the output shaft starts to run at the speed setting in last operation. Therefore check the setting of the control knob (speed). Also ensure that the speed set is suitable for the test medium selected. If you are unsure, set the motor slide to the lowest speed (front motor slide stop) using the rotary control knob (C) on the side and the gear to the lowest level.

The instrument will start up when you press the ON switch (A) on the motor.

If the unit has not been used for some time, a knocking noise will be heard when switching on, which is due to the preload on the friction lining of the friction wheel drive. This has no detrimental effect on the function of the unit, and the knocking noise will disappear after a short running-in period.

## Maintenance and cleaning

The equipment is maintenance-free. It is only subject to the natural wear and tear of components and their statistical failure rate.

### Cleaning



**For cleaning unplug the equipment!**

Use only cleaning agents which have been approved by **IKA®** to clean the instruments.

<b>Dirt</b>	<b>Cleaning agent</b>
Dye	isopropyl alcohol
Construction material	water containing tenside/ isopropyl alcohol
Cosmetics	water containing tenside/ isopropyl alcohol
Foodstuff	water containing tenside
Fuel	water containing tenside

For materials which are not listed, please request information from **IKA®** application support.

Wear protective gloves during cleaning the devices.

Electrical devices may not be placed in the cleansing agent for the purpose of cleaning.

Do not allow moisture to get into the equipment when cleaning.

Before using another than the recommended method for cleaning or decontamination, the user must ascertain with **IKA®** that this method does not destroy the instrument.

When cleaning the unit, take particular care not to bring substances containing oil or grease into contact with the running surfaces of the cone pulley and the friction wheel. This would substantially reduce the frictional coefficient resulting from the pairing of the friction wheel and cone pulley materials, and would impair power transmission in the unit.

### Spare parts order

When ordering spare parts, please give:

- machine type
- manufacturing number, see type plate
- item and designation of the spare part see **www.ika.com**, spare parts diagram and spare parts list
- software version.

### Repair

**Please send in equipment for repair only after it has been cleaned and is free from any materials which may constitute a health hazard.**

For repair, please request the “**Decontamination Certificate**” form **IKA®** or use the download printout of it from **IKA®** website: **www.ika.com**.

If you require servicing, return the equipment in its original packaging. Storage packaging is not sufficient. Please also use suitable transport packaging.

## Error codes

The fault is shown by an error code on the display (D) as following if the error occurs, e.g. **Er 4**.

Proceed as follows in such cases:

- ☞ Switch the device switch (B) off.
- ☞ Remove the stirrer tool and remove the instrument from the assembly.
- ☞ Reduce the speed and switch on (instrument switch (A)) the device without the stirrer tool.

Error code	Cause	Effect	Solution
<b>Er 8</b>	Speed sensor fault or overload	motor off	Switch off the instrument

If the actions described fails to resolve the fault or another error code is displayed then take one of the following steps:

- Contact the service department
- Send the instrument for repair, including a short description of the fault.

## Warranty

In accordance with **IKA**<sup>®</sup> warranty conditions, the warranty period is 24 months. For claims under the warranty please contact your local dealer. You may also send the machine direct to our factory, enclosing the delivery invoice and giving reasons for the claim. You will be liable for freight costs.

The warranty does not cover worn out parts, nor does it apply to faults resulting from improper use, insufficient care or maintenance not carried out in accordance with the instructions in this operating manual.

## Accessories

<b>R 472</b>	Floor stand	<b>R 4765</b>	Floor stand
<b>R 474</b>	Telescopic stand	<b>SI 400</b>	Safety switch
<b>R 301</b>	Stirring shaft protection	<b>SI 472</b>	Fixing device
<b>R 301.1</b>	Support holder	<b>SI 474</b>	Fixing device
<b>R 303</b>	Stirring shaft protection		

## Permitted IKA<sup>®</sup> stirrer tools

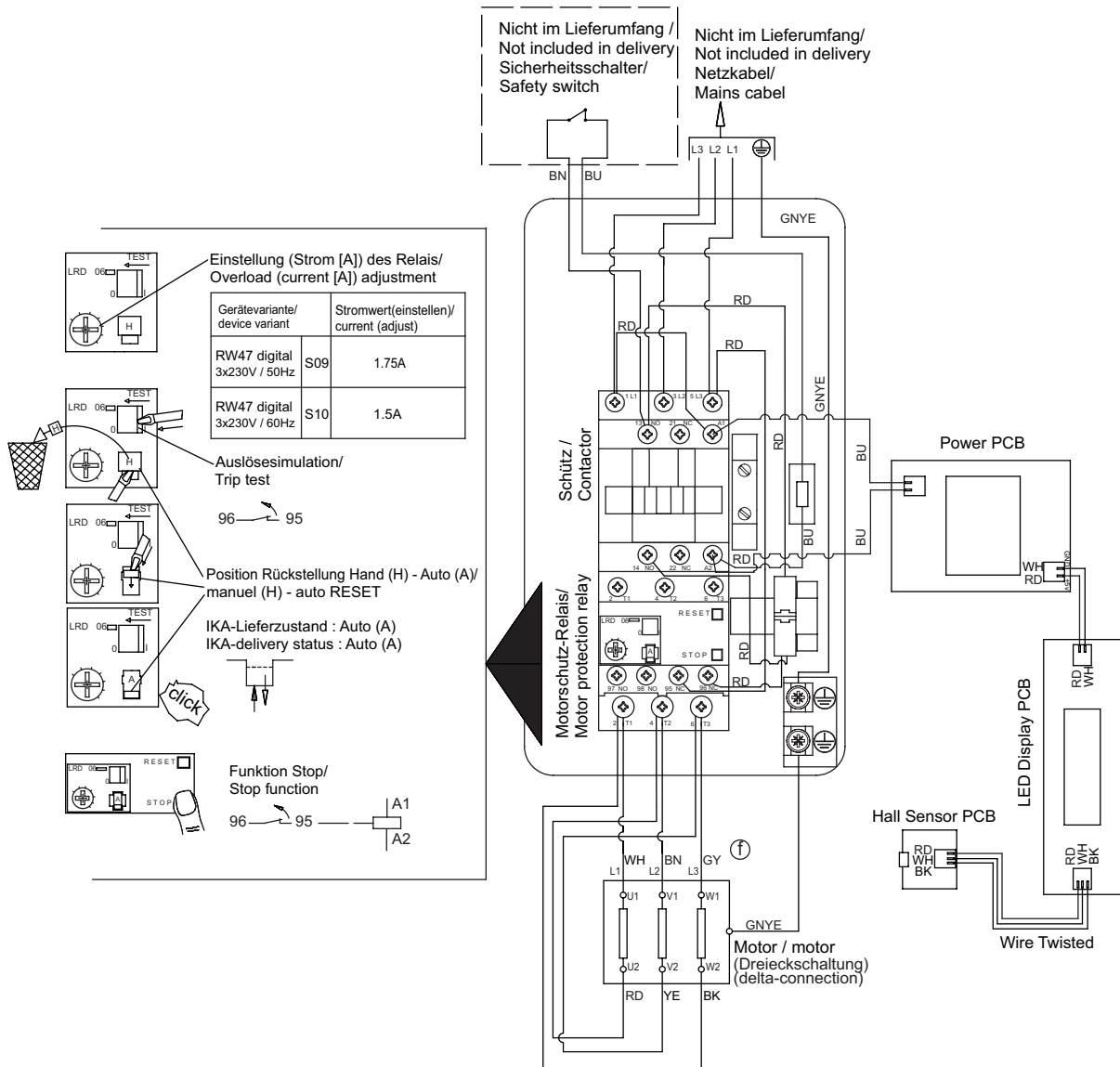
<b>R 1345</b>	Propeller stirrer	<i>Max. Speed rpm</i>	≤ 800	<b>R 1355</b>	Centrifugal stirrer	<i>Max. Speed rpm</i>	≤ 800
<b>R 2302</b>	Propeller stirrer		≤ 600	<b>R 1376</b>	Paddle stirrer		≤ 800
<b>R 1385</b>	Propeller stirrer		≤ 800	<b>R 2311</b>	Paddle stirrer		≤ 600
<b>R 1388</b>	Propeller stirrer		≤ 400	<b>R 1333</b>	Anchor stirrer		≤ 800
<b>R 1302</b>	Dissolver stirrer		≤ 1000				

## Technical data

Speed range	(50Hz stage I) (50Hz stage II) (60Hz stage I) (60Hz stage II)	<b>rpm</b>	57 – 275 275 – 1300 69 – 330 330 – 1560			
Speed adjustment			Stepless			
Speed display			Display (LED)			
Speed setting accuracy		<b>rpm</b>	± 1			
Deviation of speed measurement		<b>rpm</b>	± 10			
Max. torque stirrer shaft		<b>Ncm</b>	4642 (with 57 rpm) 3000 (with 100 rpm) 285 (with 1000 rpm )			
Maximum stirring quantity (water)		<b>ltr</b>	200			
Max. viscosity		<b>mPas</b>	100000			
Permitted on-time		<b>%</b>	100			
Nominal voltage		<b>VAC</b>	3 x 400 Y	3 x 230 Δ	3 x 400 Y	3 x 230 Δ
Frequency		<b>Hz</b>	50	50	60	60
Motor speed		<b>rpm</b>	2870	2870	3425	3425
Motor input power		<b>W</b>	513	516	489	490
Motor output power		<b>W</b>	370	370	370	370
Maximum output at stirrer shaft		<b>W</b>	300	300	300	300
Protection type to DIN EN 60529			IP 54 (only when the (4x) M8 screws are fixed at the bottom of the device)			
Protection class			I (protective earth)			
Excess voltage category			II			
Contamination level			2			
Protection at overloaded			Yes / overcurrent and undervoltage switch on the three-phase motor			
Fuse (adjustable)		<b>A</b>	1	1,75	0,86	1,5
Perm. ambient temperature		<b>°C</b>	+ 5 to + 40			
Perm. ambient humidity (rel.)		<b>%</b>	80			
Drive			Rib cooled three-phase motor with friction wheel drive and subsequent 2-stage toothed gear train			
Clamping chuck – clamping range		<b>mm</b>	3 – 16			
Housing			Coated aluminium casting and thermoplastic plastic			
Dimension (W x D x H)		<b>mm</b>	145 x 465 x 358			
Weight (with clamping chuck)		<b>kg</b>	16			
Operation at a terrestrial altitude		<b>m</b>	max. 2000 above sea level			

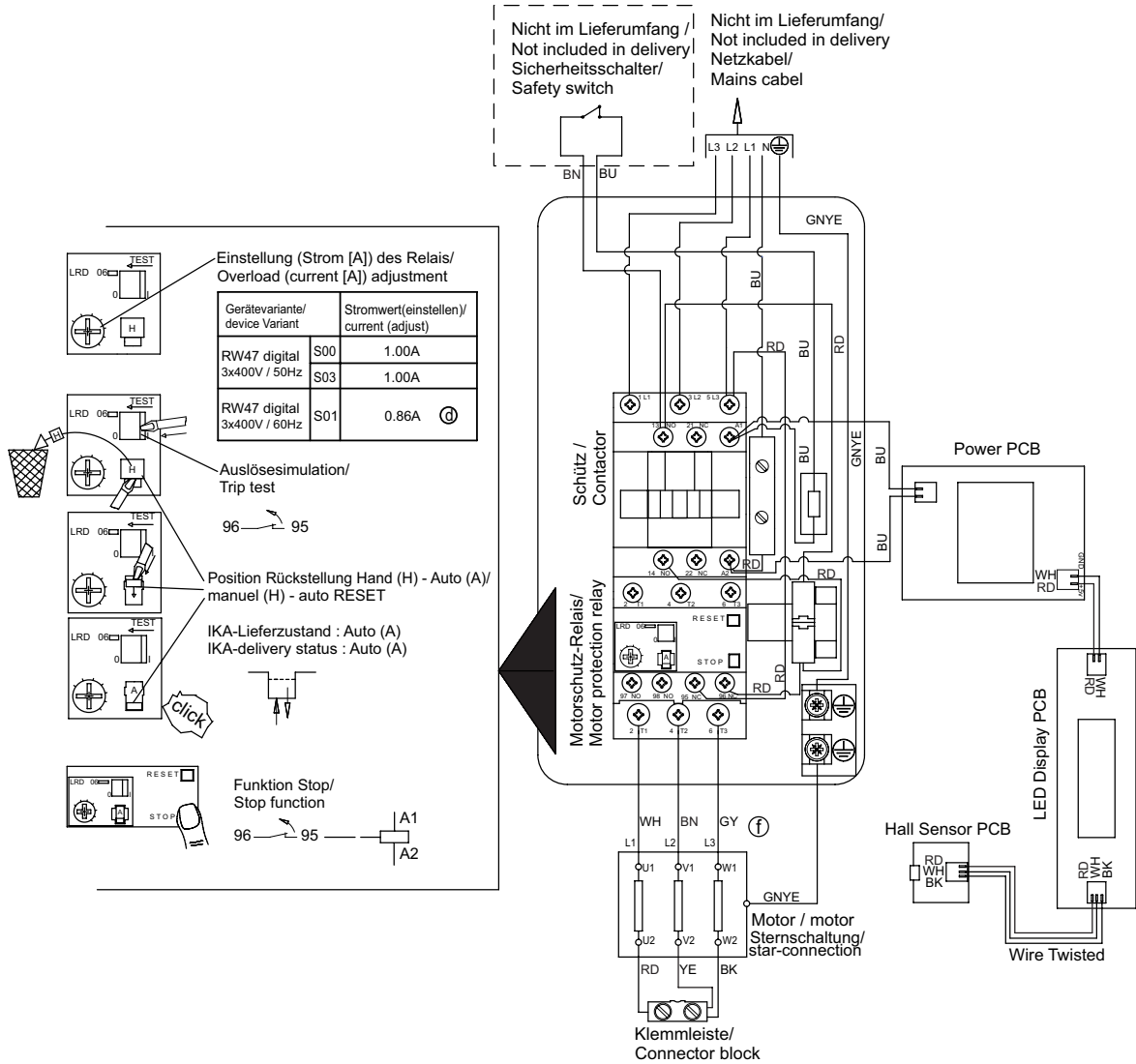
*Subject to technical changes!*

# Verdrahtungsplan / wiring diagram: 3x 230V / 50/60Hz



Litzenkennzeichnung nach IEC 60757/  
Stranded conductor colour coding to IEC 60757

# Verdrahtungsplan / wiring diagram: 3x 400V / 50/60Hz



Litzenkennzeichnung nach IEC 60757/  
Stranded conductor colour coding to IEC 60757



**IKA® - Werke GmbH & Co.KG**

Janke & Kunkel-Str. 10

D-79219 Staufen

Tel. +49 7633 831-0

Fax +49 7633 831-98

[sales@ika.de](mailto:sales@ika.de)

**[www.ika.com](http://www.ika.com)**