

20000004638a

RW 28 digital_032016

IKA®

IKA® RW 28 digital



Operating instructions

EN



IKA®-Werke, Germany
Reg. No. 004343

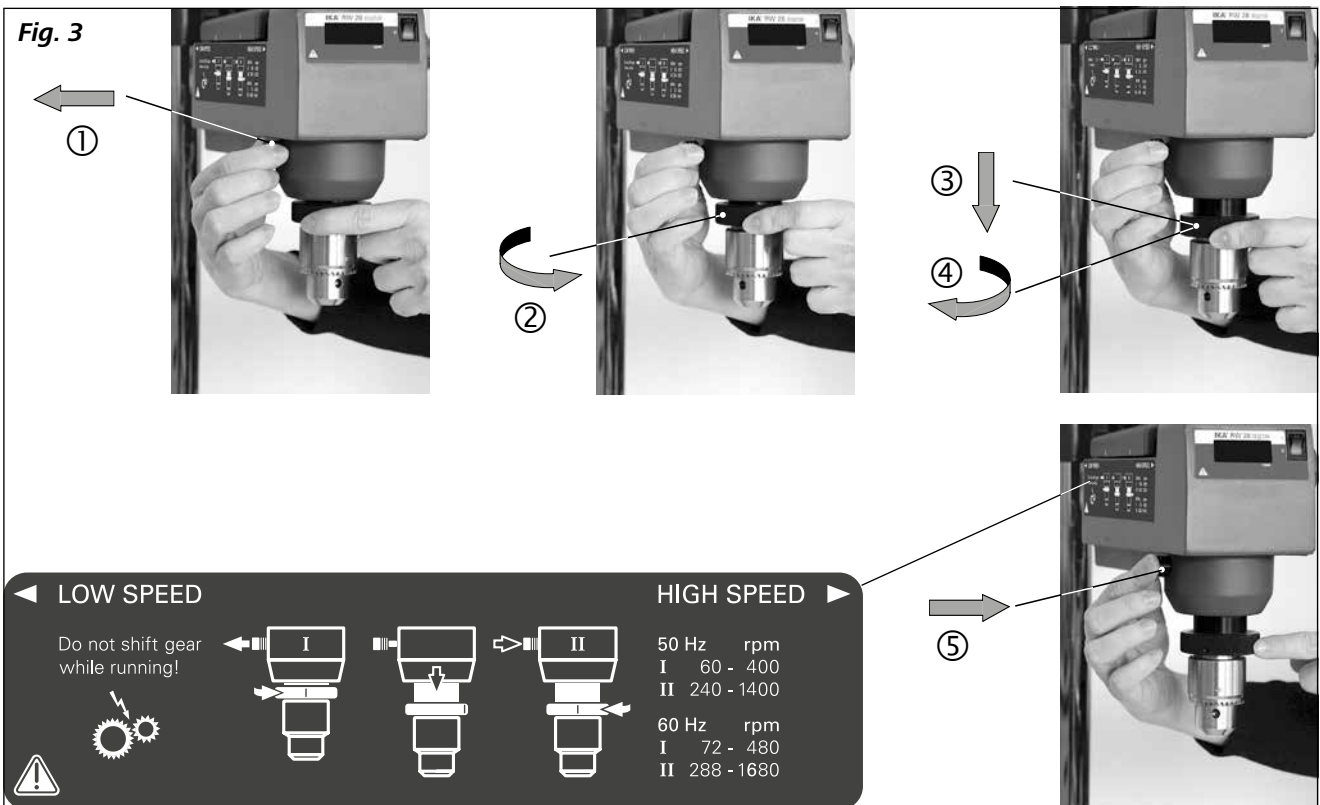
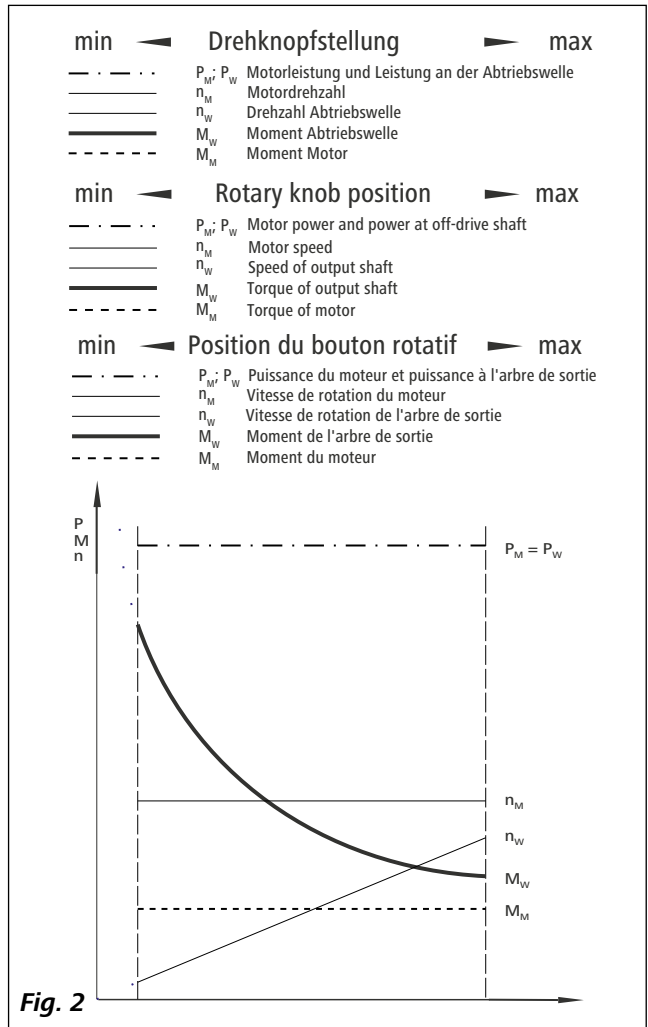
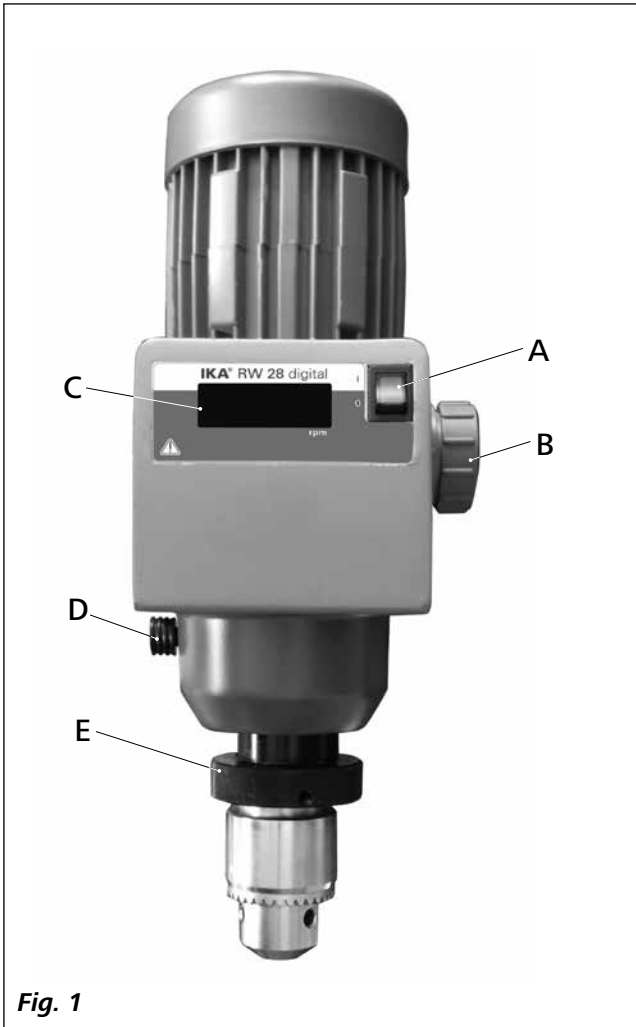

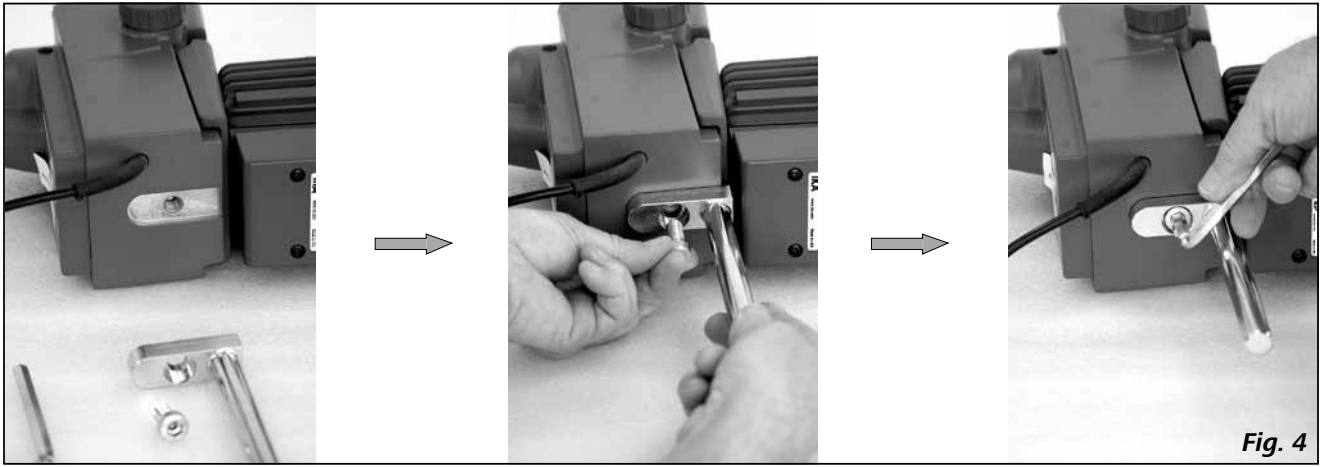

Fig. 4

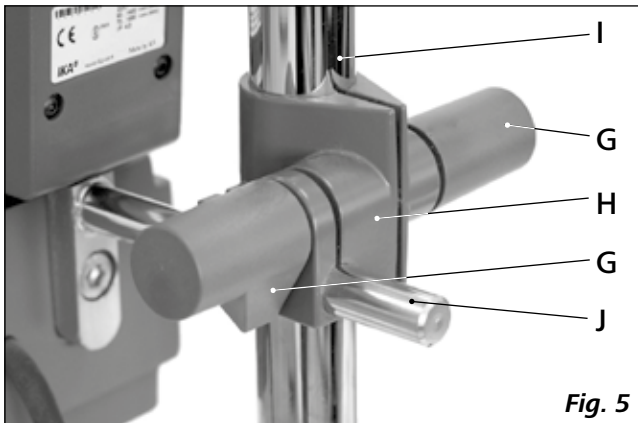

Fig. 5

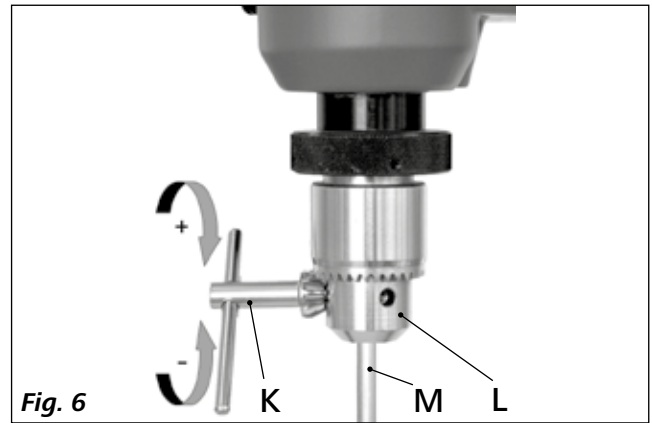

Fig. 6

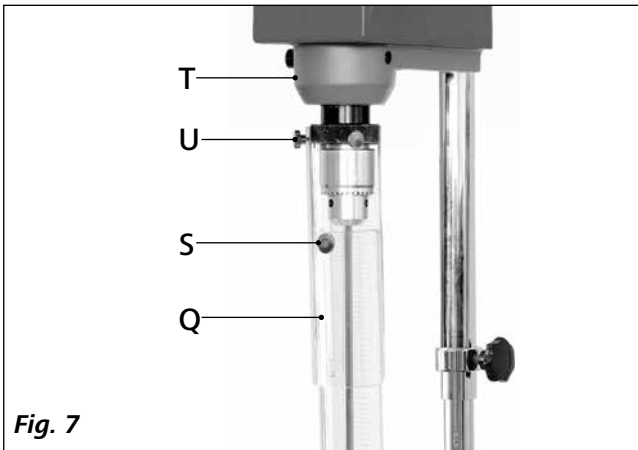

Fig. 7

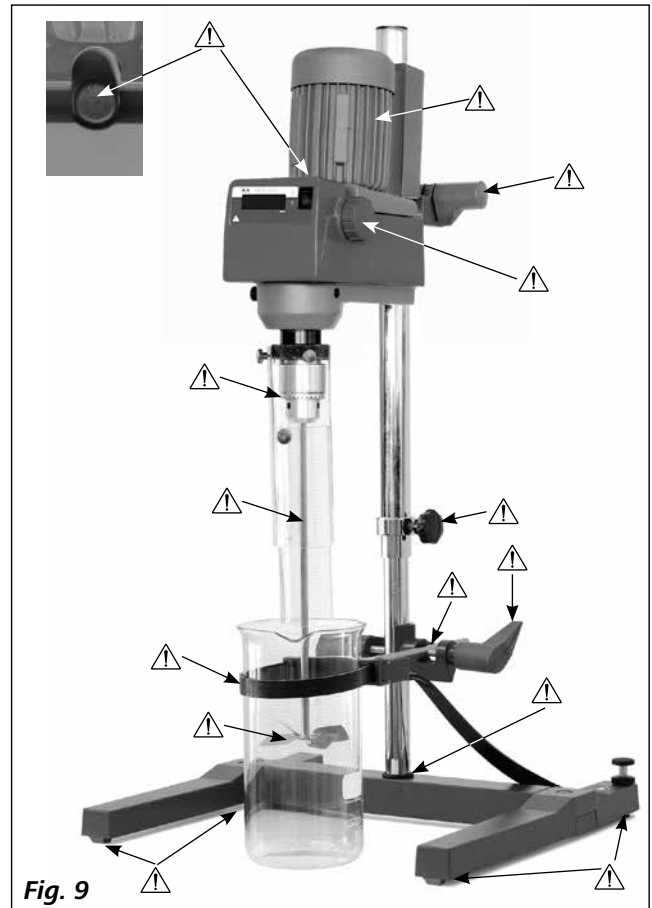

Fig. 9

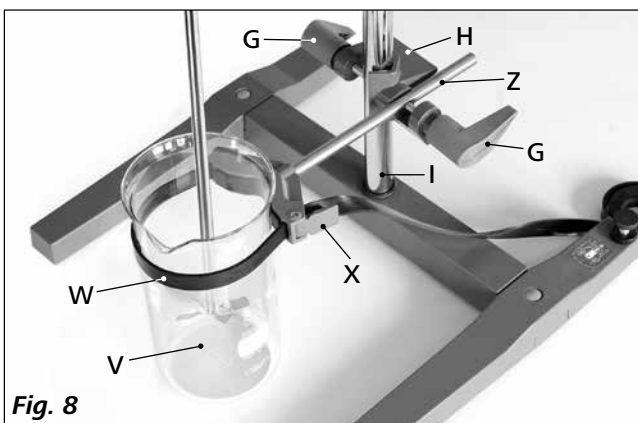

Fig. 8

Contents

	Page
Declaration of conformity	4
Explication of warning symbols	4
Safety instructions	5
Correct use	6
Unpacking	7
Useful information	7
Drive	7
Motor circuit breaker	7
Gear speed change	8
Output shaft	8
Speed display	8
Commissioning	8
Securing	9
Switching on the machine	9
Maintenance and cleaning	10
Error codes	10
Warranty	11
Accessories	11
Permitted IKA [®] stirrer tools	11
Technical data	12

Declaration of conformity

We declare under our sole responsibility that this product corresponds to the regulations 2014/35/EU, 2006/42/EC, 2014/30/EU and 2011/65/EU and conforms with the standards or standardized documents: EN 61010-1, EN 61010-2-051, EN 61326-1, EN 61326-1, EN 60529 and EN ISO 12100.

Explication of warning symbols



Indicates an (extremely) hazardous situation, which, if not avoided, will result in death, serious injury.



Indicates a hazardous situation, which, if not avoided, can result in death, serious injury.



Indicates a potentially hazardous situation, which, if not avoided, can result in injury.



Indicates practices which, if not avoided, can result in equipment damage.



Beware of injury from rotating part because of automatically restart after an interruption in the power supply or a mechanical interruption.

Safety instructions

- **Read the operating instructions in full before starting up and follow the safety instructions.**
- Keep the operating instructions in a place where it can be accessed by everyone.
- Ensure that only trained staff work with the instrument.
- Follow the safety instructions, guidelines, occupational health and safety and accident prevention regulations.
- Because the options for combining products, tools, stirring vessel, experiment and medium are nearly endless, user safety cannot be ensured simply with design requirements on the part of the product. For this reason, it may become necessary for users to take other precautionary safety measures. For example, glass apparatus or other stirring vessels that are sensitive to mechanical stress can be damaged or shattered by an imbalance, increasing the speed too quickly or too little distance between the stirring element and the stirring vessel. Users can suffer serious injury from glass breakage or from the freely rotating stirring element.
- Uncontrolled reactions can be triggered by mixing the heated material insufficiently or by the energy generated by selecting a speed that is too high. In case of these and other increased operational hazards, users must take additional appropriate safety precautions (e.g. shatter protection). In any case, when using critical or hazardous materials in your processes, **IKA®** recommends to use additional appropriate measures to ensure safety in the experiment. For example, users can implement measures that inhibit fire or explosions or comprehensive monitoring equipment. Furthermore, users must make sure that the **OFF** switch of the **IKA®** product can be accessed immediately, directly and without risk at any time, and above all, in case of fault.

NOTICE

If mains switch cannot ensure this access at all times, an additional **EMERGENCY STOP**

switch that can be easily accessed must be installed in the work area.

- Only process media that will not react dangerously to the extra energy produced through processing. This also applies to any extra energy produced in other ways, e.g. through light irradiation.
- Do not operate the instrument in explosive atmospheres, with hazardous substances or under water.
- Process pathogenic materials only in closed vessels under a suitable fume hood. Please contact **IKA®** application support if you have any question.
- The instrument is not suitable for manual operation.
- The high torque developed by the **RW 28 digital** requires particular care in the choice of stand, cross sleeve and anti-rotation element for the agitating vessel.
- Set up the stand in a spacious area on an even, stable, clean, non-slip, dry and fireproof surface.

- You must ensure that the stirring element is securely clamped in the chuck!

DANGER

Remove the chuck key from the chuck before turning on the device.

- Use stirring shaft protective equipment!
- The agitated vessels used for stirring have to be secured. Consider on a good stability of the entire structure.

CAUTION

Please pay attention to the dangerous parts of the equipment in **Fig. 9**.

- Protect the instrument and accessories from bumping and impacting.
- Check the instrument and accessories beforehand for damage each time when you use them. Do not use damaged components.
- Safe operation is only guaranteed with the accessories described in the "**Accessories**" section.
- Always switch the main switch in the **OFF** position or disconnect the power before changing stirring element and fitting allowed accessories.
- The instrument can only be disconnected from the mains supply by pulling out the mains plug or the connector plug.
- The socket for the mains cord must be easily accessible.
- Socket must be earthed (protective ground contact).
- The voltage stated on the type plate must correspond to the mains voltage.
- Please observe the permitted speed for the stirring element. Never set higher speed.
- Make certain that the unit is set at the lowest speed before commissioning; otherwise, the unit will begin running at the speed set in last operation. Gradually increase the speed.
- Pay attention when setting the speed to any imbalance of the stirrer tools and possible spraying of the medium to be stirred.

WARNING

Never operate the instrument with the stirrer tools rotating freely. Ensure that parts of the

body, hair, jewelry or items of clothing cannot be trapped by the rotating parts.

WARNING

The operation of a free rotating shaft end is dangerous. Therefore, for safety reasons, only

insert through the stirring tool over the upper edge of housing at standstill.

 **CAUTION**

Wear your personal protective equipment in accordance with the hazard category of the medium to be processed. There is a risk of:

- splashing of liquids
- projectile parts
- body parts, hair, clothing and jewelry getting caught.

 **NOTICE**

Beware of the risk of:

- flammable materials
- glass breakage as a result of mechanical shaking power.

 **NOTICE**

Reduce the speed if:

- the medium splashes out of the vessel because the speed is too high
- the instrument is not running smoothly
- the instrument begins to move around because of dynamic forces
- an error occurs.

 **DANGER**

Do not touch rotating parts during operation!

 **WARNING**

Beware of injury from rotating parts. After an interruption in the power supply or a mechanical interruption, the unit will restart automatically. Keep hands away from rotating or moving parts.

- There may be electrostatic activity between the medium and the output shaft which could cause a direct danger.
- It is important to note that the surfaces of the motor (cooling fins) and certain parts of the bearing may get very hot during operation.

- Never cover the ventilation slots or cooling fins on the motor or on the instrument.
- Avoid knocking and impacting on the lower end of the shaft and the chuck gear teeth. Even minor, invisible damage can lead to imbalance and uneven shaft action.
- Ensure that the stand does not start to move.
- Imbalance of the output shaft, the chuck and in particular the stirring tools can lead to uncontrolled resonant vibrational behavior of the instrument and the whole assembly. Glass apparatus and stirrer containers can be damaged or shattered by this. It can cause injury to the operator, also can damage the rotating stirring tool. In this case exchange the stirring tool for one without imbalance or remedy the cause of the imbalance. If there is still imbalance, return it to the dealer or the manufacturer along with a description of the fault.
- If the instrument is operated too long in overload or if the ambient temperature is too high, the instrument switches off permanently.
- The machine must only be opened by trained specialists, even during repair. The instrument must be unplugged from the power supply before opening. Live parts inside the instrument may still be live for some time after unplugging from the power supply.

 **NOTICE**

Covering or parts that are capable of being removed from the unit without accessory equipment have to be reattached to the unit for safe operation in order to prevent, for example, the ingress of fluids, foreign matter, etc..

 **NOTICE**

The unit must be switched off (motor standstill) before changing to another gear speed, otherwise the toothed gears in the reduction stage will be damaged.

Correct use

- **Use:**
For mixing/stirring liquids with low to high viscosity by using various stirring tools.

Intended use: Stand device (Chuck downward).

- **Range of use (indoor use only):**
 - Laboratories
 - Pharmacies
 - Schools
 - Universities

This equipment is suitable for use in all areas except:
- Residential areas
- Areas that are connected directly to a low-voltage supply network that also supplies residential areas.

The safety of the user cannot be guaranteed:
- If the instrument is operated with accessories that are not supplied or recommended by the manufacturer
- If the instrument is operated improperly or contrary to the manufacturer's specifications
- If the instrument or the printed circuit board are modified by third parties.

Unpacking

• Unpacking:

- Please unpack the device carefully
- In the case of any damage a detailed report must be sent immediately (post, rail or forwarder)

• Delivery scope:

- **RW 28 digital** overhead stirrer
- user guide
- extension arm
- hexagonal socket screw
- hexagon socket offset screw key
- chuck key
- warranty card.

Useful information

The speed can be infinitely adjusted between 60 and 1400 rpm 50 Hz; 72 and 1680 rpm 60 Hz. The machine can be operated continuously and warms up during operation. The generously proportioned cooling surfaces enable distribution and transference of heat to be as even as possible.

The two meters long mains lead makes it possible to work on stands - even with high glass apparatus under vapor extraction hoods - without extension leads.

The precision stirrer shaft is designed as a hollow shaft to allow the stirrer shanks to be inserted.

Drive

The motor can be infinitely adjusted via a friction wheel drive unit but is operated in one position only. The power output, rotational speed and torque of the motor are regarded as constant and are optimized for this operating position. After the friction wheel drive the motor power output is transmitted to the output shaft of the stirrer via either the first or second stage of the subsequent manually adjustable toothed gear train.

Neglecting all losses, the power at the output shaft during power transmission (conversion) is always as great as the power output of the motor.

The gear train merely provides rpm and torque conversion, which can be described in purely theoretical terms by the characteristic curve plotted in **Fig. 2**.

Friction wheel wear is kept low by a helical clutch matched to the gear train. The down-pressure required at the friction wheel is adjusted by the helical clutch according to the moment acting on the stirrer shaft. A low torque results in a low down-pressure; a high torque results in a high down-pressure.

Motor circuit breaker

The ball race capacitor motor (degree of protection IP 42) is maintenance free. In its winding it carries a special overheating circuit breaker (self-locking temperature limiter) which shuts down the motor permanently if the permissible motor temperature is exceeded.

This special type of circuit breaker is used when the automatic reactivation of the protected unit after overheating is undesirable or impermissible. The principle of the temperature limiter is that of a switch that heats up and isolates the motor from the power supply when the maximum permissible temperature is reached.

When the self-locking temperature is exceeded, **Er 4** is shown on the display (see section "**Error codes**").

In this case the unit can only be switched back on after it has been switched off for approx. 4-5 minutes by pressing the rocker switch (A, see **Fig. 1**) on the front or by disconnecting the mains plug.

After this short cooling, the contacts in the current circuit are closed again and the unit is operational once more.

Gear speed change

(Fig 3)

After the locking knob (D, see Fig. 1) on the left side of unit is pulled, the gears could be taken out of mesh by turning in counterclockwise direction to the bearing bushing on the black knurled surface (E, see Fig. 1) above the chuck. The centre axis of the stirring apparatus is thus shifted in a radial direction. The bearing bushing is then axially positioned up or down in accordance with the range which is to be set. The gears are put back into mesh by turning the bearing bushing back (clockwise) and the centre axis of the agitator is swiveled into the original position until the locking knob (D, see Fig. 1) catches.

It should be necessary to change the gear speed in the course of setting up an experiment or process with glass apparatus, then attention must be paid to the movement of the stirrer element by the eccentric bearing bush and to the movement in the axial direction. If this is unacceptable, the stirrer element must be loosened in the chuck.



DANGER

Only change the gear position at standstill!

Output shaft

The clamping chuck and output shaft permit clamping IKA® recommend stirrer tools (see “Permitted IKA® Stirrer tools” section).

The output shaft is designed as a hollow shaft, and the opening on the top side of the housing is closed with a stirrer cover. When the stirrer cover is opened, it is possible for stirring shaft to be pushed out over the top edge of the housing at **standstill**, e.g. during changing container.

For safety reason, the stirrer cover must be pushed back into the opening of the housing so that it is properly closed. This is the only way to ensure that working with the unit is safe and that media cannot enter the instrument.



NOTICE

Please see section “Safety instructions”!

Speed display

The rotation speed is adjusted by means of the rotary knob (B, see Fig. 1) on the side of the overhead stirrer.

The rotational speed is displayed directly in revolutions per minute (rpm) on the display (C, see Fig. 1).

Commissioning

Assemble the overhead stirrer and all necessary accessories on a stable, even, non-slip surface. The **RW 28 digital** overhead stirrer must be secured to a stable stand (e.g. **R 2722** or **R 2723**) with a cross-sleeve (e.g. **R 271**). The stirring vessel must always be securely fixed for safety reasons. You must also ensure that the mounting device (stand) is set up in such a way that it is not liable to topple and does not start to move during the stirring procedure.

Accessories must be assembled according to the following assembly instructions (Fig. 4 to Fig. 8).

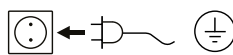

If above conditions are met, the instrument is ready for operation after plugging in the mains plug.

Securing

Securing extension arm to the overhead stirrer

Diagram (see Fig. 4)

Ensure that the extension arm is fitted securely.

Vibration may cause the screw to become loose. It is therefore necessary for safe use to occasionally check that the extension arm is attached securely. Tighten the hexagon socket screw as required.

Securing the stirrer to the stand

Diagram (see Fig. 5)

Attach the cross sleeve (H) to the upright of the stand (I). Attach the extension arm (J) to the side of the cross sleeve not in use, with the opening facing upwards.

Tighten both clamping bolts (G) firmly once the desired position for the stirring procedure has been adjusted correctly. Check that the stirrer is held in position firmly prior to each use and also at regular intervals. The position of the stirrer must only be adjusted when the equipment is stationary and the power supply is disconnected.

Securing a stirring element using the chuck

Diagram (see Fig. 6)

Slide the stirring tool (M) into the chuck (L). Tighten the chuck firmly using the chuck key (K).

The stirring tool must only be changed when the equipment is stationary and the power supply is disconnected.

Securing the stirring shaft protector

Diagram (see Fig. 7)

Use a stirring shaft protector (Q), e.g. **R 301**, to provide protection against injury when working with the equipment. Use the bolts (U) to attach the plastic half-shell pieces to the stirrer (T), as shown in **Fig. 7**. The screw (S) can be used to adjust the length of the stirring shaft protector.

Check that the stirring shaft protector is held in position securely prior to each use and also at regular intervals. The position of the stirring shaft protector must only be adjusted when the equipment is stationary and the power supply is disconnected.

Securing the mixing vessel to the stand

Diagram (see Fig. 8)

First fix the cross sleeve (H) to the stand (I).

Then attach the bracket (Z) of the strap clamp in the open side of the cross sleeve which is facing upwards according to the position of stirrer and the mixing vessel (V), firmly tighten the two clamping bolts (G).

Clamp the mixing vessel (V) with the flexible clamping band (W) and secure the flexible band (W) by means of the clamping lever (X).

Switching on the device

Check whether the voltage given on the type plate corresponds to the available mains voltage.

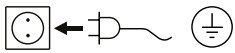

The socket used must be earthed (fitted with earth contact).

If these conditions have been met, the machine is ready to operate when the mains plug is plugged in.

If these conditions are not met, safe operation is not guaranteed and the machine could be damaged.

During commissioning of the machine the output shaft starts to run at the last speed set. Therefore check the setting of the control knob (B). Also ensure that the speed set is suitable for the test medium selected.

If in doubt, set the speed knob to the lowest speed. In case of doubt use the rotary knob (B, see **Fig. 1**) to set the lowest speed and set the drive at the lowest speed position (back side, refer to the attachment on side of overhead stirrer).

The unit starts to run when the rocker switch (A, see **Fig. 1**) is switched to **I** position.

If the unit has not been used for some time, a knocking noise will be heard when switching on, which is due to the preload on the friction lining of the friction wheel drive. This has no detrimental effect on the function of the unit, and the knocking noise will disappear after a short running-in period.

Maintenance and cleaning

The equipment is maintenance-free. It is only subject to the natural wear and tear of components and their statistical failure rate.

Cleaning:

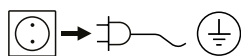

For cleaning disconnect the main plug!

Use only cleaning agents which have been approved by **IKA®** to clean the instrument.

Dirt	Cleaning agent
Dye	isopropyl alcohol
Construction material	water containing tenside/ isopropyl alcohol
Cosmetics	water containing tenside/ isopropyl alcohol
Foodstuff	water containing tenside
Fuel	water containing tenside
For materials which are not listed, please request information from IKA® .	

Wear protective gloves during cleaning the instrument.

Electrical devices may not be placed in the cleansing agent for the purpose of cleaning.

Do not allow moisture to get into the equipment when cleaning.

Before using another than the recommended method for cleaning or decontamination, the user must ascertain with **IKA®** that this method does not destroy the instrument.

When cleaning the unit, take particular care not to bring substances containing oil or grease into contact with the running surfaces of the cone pulley and the friction wheel. This would substantially reduce the frictional coefficient resulting from the pairing of the friction wheel and cone pulley materials, and would impair power transmission in the unit.

Spare parts order:

When ordering spare parts, please give:

- machine type
- serial number, see type plate
- item and designation of the spare parts, see **www.ika.com**
- Software version.

Repair:

Please send equipment for repair only after it has been cleaned and is free from any materials which may constitute a health hazard.

For repair, please request the “**Decontamination Certificate**” form **IKA®** or use the download printout of it from **IKA®** website: **www.ika.com**.

If you require servicing, return the equipment in its original packaging. Storage packaging is not sufficient. Please also use suitable transport packaging.

Error codes

The fault is shown by an error code on the display (C) as following if the error occurs, e.g. **Er 4**.

Proceed as follows in such cases:

- ☞ Switch the device switch (A) off.
- ☞ Remove the stirrer tool and remove the instrument from the assembly.
- ☞ Reduce the speed and switch on (instrument switch (A)) the device without the stirrer tool.

Error code	Cause	Effect	Solution
Er 4	Motor blockage or overload	motor off	- Switch off the instrument - Decrease the motor's load and restart again
Er 8	Speed sensor fault or overload	motor off	- Switch off the instrument

If the actions described fails to resolve the fault or another error code is displayed then take one of the following steps:

- Contact the service department
- Send the instrument for repair, including a short description of the fault.

Warranty

In accordance with **IKA**[®] warranty conditions, the warranty period is 24 months. For claims under the warranty please contact your local dealer. You may also send the machine direct to our factory, enclosing the delivery invoice and giving reasons for the claim. You will be liable for freight costs.

The warranty does not cover worn out parts, nor does it apply to faults resulting from improper use, insufficient care or maintenance not carried out in accordance with the instructions in this operating manual.

Accessories

R 2722	H-Stand	RH 5	Strap clamp
R 2723	Telescopic stand	FK 1	Flexible coupling
R 270	Cross sleeve	R 301	Stirrer shaft protection
R 271	Cross sleeve	R 301.1	Support holder

See more accessories on www.ika.com.

Permitted IKA[®] stirrer tools

		<i>recommended speed (rpm)</i>		<i>recommended speed (rpm)</i>	
R 1345	Propeller stirrer	≤ 800	R 1355	Centrifugal stirrer	≤ 800
R 1385	Propeller stirrer	≤ 800	R 1375	Paddle stirrer	≤ 800
R 1388	Propeller stirrer	≤ 400	R 1376	Paddle stirrer	≤ 800
R 1313	Turbine stirrer	≤ 800	R 1331	Anchor stirrer	≤ 1000
R 1300	Dissolver stirrer	≤ 2000	R 1333	Anchor stirrer	≤ 800
R 1302	Dissolver stirrer	≤ 1000			

Technical data

Speed range:	(50 Hz stage I) (50 Hz stage II) (60 Hz stage I) (60 Hz stage II)	rpm	60–400 240–1400 72–480 288–1680
Speed adjustment			Stepless
Speed display			Display (LED)
Speed setting accuracy		rpm	± 1
Speed measurement deviation		rpm	± 10
Max. torque at stirrer shaft:	(at 60 rpm) (at 100 rpm) (at 1000 rpm)	Ncm	1144 900 86
Maximum stirring quantity (water)		ltr	80
Max. viscosity		mpas	50000
Permitted on-time		%	100
Nominal voltage		VAC	220–240 ± 10 % 100–115 ± 10 %
Frequency		Hz	50 / 60
Input power (motor)		W	220 (220–240 V / 50 Hz) 300 (100–115 V / 60 Hz)
Output power (motor)		W	90 (220–240 V / 50 Hz) 94 (100–115 V / 60 Hz)
Output power shaft (measured at 400 rpm in stage I, 230V 50 Hz)		W	90
Protection type to EN 60529			IP 40
Protection class			I (protective earth)
Excess voltage category			II
Contamination level			2
Protection at overloaded			Yes / temperature sensor in motor winding
Ambient temperature		°C	+ 5 ... + 40
Ambient humidity (rel.)		%	80
Drive			Rib cooled capacitor motor with friction wheel drive and subsequent 2-stage toothed gear train
Clamping chuck – clamping range		mm	1–10
Hollow shaft internal diameter (Ø)		mm	10.5
Extension arm (Ø x L)		mm	16 x 145
Housing			Coated aluminium casting and thermoplastic plastic
Dimension (W x D x H) (without extension arm)		mm	123 x 252 x 364
Weight (with extension arm and clamping chuck)		kg	7.5
Operation at a terrestrial altitude		m	max. 2000

Subject to technical changes!

IKA®-Werke GmbH & Co.KG

Janke & Kunkel-Str. 10

D-79219 Staufen

Tel. +49 7633 831-0

Fax +49 7633 831-98

sales@ika.de

www.ika.com