

-40°C Biomedical Freezer

— DW-40L92



Hydrocarbon (HC) Energy-saving

DW-40L92 adopts an hydrocarbon inverter compressor system, energy-saving and efficient, delivers a power consumption as low as 1.42KW·h/24h.



Environmentally Friendly

The HC system is a completely green refrigeration solution. With LBA foamed polyurethane insulation in line with European ROHS directive for environmentally friendly materials.



Low Noise

Optimized hydrocarbon system and structural noise reduction design, DW-40L92 noise 29 dB, super quiet and low noise.



Security Lock

Mechanical lock plus lock catch, the mechanical door lock can be opened with one key, and the door lock can be padlocked. Secure and safe, suitable for multiple users.

-40°C Biomedical Freezer DW-40L92

Product Features



Microprocessor

- Microprocessor electronic temperature controller, LCD digital temperature display, display precision is 0.1°C, temperature set point -20~-40°C.
- Multiple alarms including high and low temperature, sensor error, power failure, door ajar, high ambient and remote alarm.
- Alarm mode: sound and light alarm.
- It can be connected to remote alarm.



Undercounter Biomedical Freezer

The DW-40L92 cabinet is designed with a height of 810mm, which can be easily placed under the bench to save storage space.



Multiple Interface Options

- Standard configuration: Remote alarm interface.
- Optional configuration: USB or RS485.



Fast Pull Down and Recovery Times

DW-40L92 cools down to -40°C from 25°C ambient in around 110 minutes due to the optimised HC refrigeration system.



Low Energy Consumption

The power consumption of DW-40L92 decreases from 3.3 KW·h/day to 1.42 KW·h/day, and the energy consumption is reduced by more than 50%.



Low Noise

DW-40L92 noise decreases to 29dB, quiet and low noise.



Porthole

There is a standard access port (25mm inside diameter) on the left side of the unit, which is convenient for users to test independently.

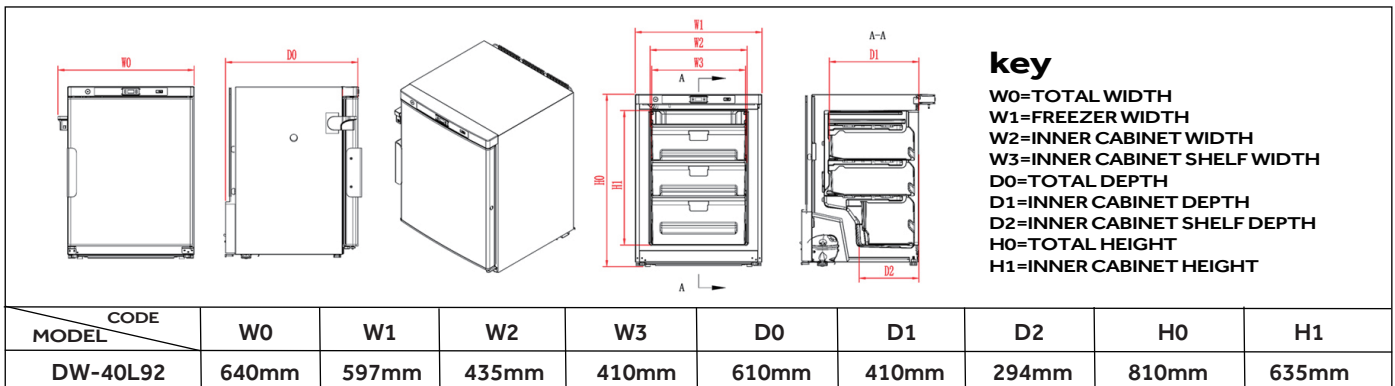
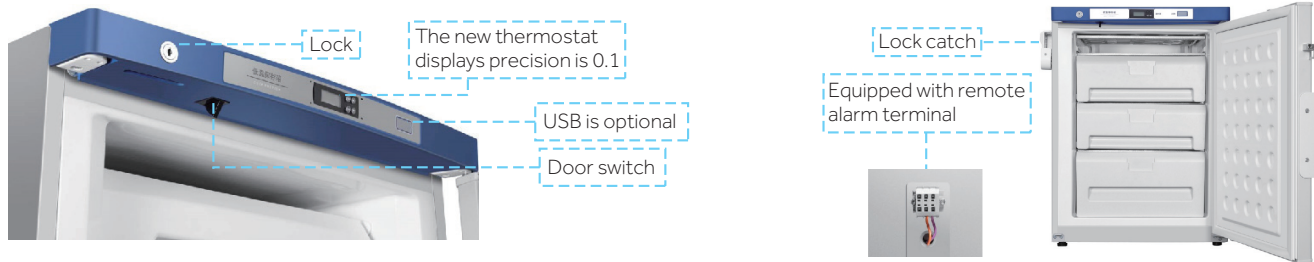

Specifications

Defrost Mode	Refrigerant	Sound Level (dB(A))	Cooling Performance (°C)	Temperature Range (°C)	Power Supply (V/Hz)	Power (W)
Manual	HC	29	-40	-20~-40	220-240/50/60	340
Electrical Current (A)	Power Consumption (kW·h/24h)	Capacity (L/Cu.Ft)	Net/Gross Weight (approx)(kg)	Internal Dimension (W*D*H)(mm)		
2.2	1.42	92/3.2	46/51	435*410*635		
Exterior Dimension (W*D*H)(mm)	Container Load (20°/40°/40°H)	Alarms	Certification			
640*610*810	48/108/108	High/Low Temperature, Remote Alarm, Power Failure, Sensor Error, High Ambient Temperature, Door Ajar	CE			



Wolflabs

Wolf Laboratories Limited

www.wolflabs.co.uk

Tel: 01759 301142

Fax: 01759 301143

sales@wolflabs.co.uk



Use the above details to contact us if this literature doesn't answer all your questions.

Pricing on any accessories shown can be found by keying the part number into the search box on our website.

The specifications listed in this brochure are subject to change by the manufacturer and therefore cannot be guaranteed to be correct. If there are aspects of the specification that must be guaranteed, please provide these to our sales team so that details can be confirmed.

