



Technical Data Sheet

Forma Ultra-Low Temperature Chest Freezer

MODEL RELEASE - 20

Thermo Fisher Scientific, Marietta, Ohio

Specifications	Model Number
	820CV
Application, Rating and Electrical Data	
Application	Storage of General (non-flammable) Laboratory Materials
Storage Volume	566.3 Liters/20 Cubic Feet
Temperature Rating	-50°C to -86°C
Electrical Power	230V 50 Hz, 1 Phase
Instrument Rated Current	12.0 AMP
Building Supply Rating	15.0A (min) dedicated grounded circuit. Protected by circuit breaker rated for inductive loads
Power Plug/Power Cord Length	Country Dependant plug / IEC Cords, 3.048 Meters (10 Feet)
Agency Listings	CE, FDA
Indoor/Outdoor Usage	Indoor Use Only
Application Environment	Non-Corrosive, Non-Flammable, Non-Explosive, Good Air Ventilation, 15° C - 32° C (59° F - 90° F)
Refrigeration Configuration	
Refrigeration System	Industrial-Rated Two Stage Cascade System
Compressor / Number	Hermetic Compressor for Low Temperature Application / 2
Compressor Capacity*	730 W
Condenser Type/Number	Enhanced Finned-Tube and Forced-Air Cooled / 1
Expansion Device	Capillary Tube
Evaporator Type	Cold Wall With Enhanced Heat Transfer Treatment
Defrost Method	Manual Defrost
Refrigerant Charge/Flammability	R404A in 1st Stage / R508B+R290 Mix in 2nd Stage / Non-Flammable
Controller/Electrical System Configuration and Features	
Controller Level	Top
Power Switch	On-Off with Circuit Breaker
Controller Type	Microprocess Control
Setpoint Security	Yes
Compressor Safe Guard	High Pressure Cutout Switch/High Temp Cutout Switch/Current protection/Logic protection
Control Sensor	Single RTD (1000 ohm Platinum RTD)
Remote Alarm Terminals	RS485, 4-20mA, Dry Contacts
Adjustable Warm/Cold Alarms	Fully Adjustable
Auto-Voltage Safeguard	Buck/Boost System
Dimensions and Construction	
Interior Dimensions (H x D x W)	706 H x 470 D x 1687 W mm (27.8 H x 18.5 D x 66.4 W in.)
Exterior Dimensions (H x D x W)	1031 H x 848 D x 2438 W mm (40.6 H x 33.4 D x 96 W in.)
Shipping Dimensions	1168 H x 973 D x 2677 W mm (46 H x 38.3 D x 105.4 W in.)
Insulation	High Density Polyurethane Foam, R-30 (ft ² ·°F·hr/Btu)
Door Seal	Silicone-Based High Performance Seal Gasket
Shelves / Capacity	N/A
All-Direction Casters	Standard with Locks
Unit Weight	Approximately 355 kg / 783 lbs.
Other Options	Electronic Recorder and CO ₂ or LN ₂ Back-Up System

Typical Performance Characteristics in 25 ° C Ambient

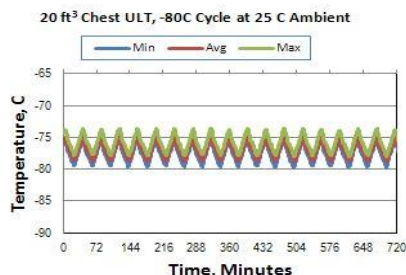
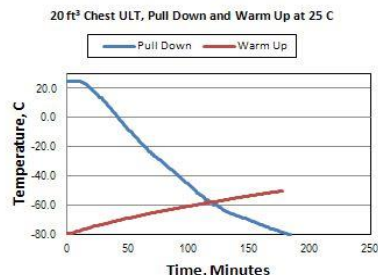

Test Unit Series or MSO Number:	18828-D-E
Avg Cabinet Temp at -80 C Cycle (C):	-77.0
Peak Variation from Setpoint (C):	+ 6.5 / + 0.2
Average Uniformity (C):	1.7
Average Stability (C):	4.2
Duty Cycle at -80C Setpoint (%):	56.5%
Cycle (on/off) rate at -80C (min):	22 / 17
Avg. energy consumption (kW-hr/day):	14.7
Avg. heat rejection rate (Btu/hr):	2090
Overall Pulldown Time (to -80C) (hrs):	3.1
Warmup Time (-80 to -50 C) (minutes):	177
BTU Capacity at -80C Setpoint (BTU/Hr)	267

- 1) Performance is nominal and individual units may vary.
- 2) Freezer performance will differ due to product amount, product size and operating conditions.
- 3) Continuous product enhancements may, without notice, result in amendments or omissions to this specification. Thermo Scientific cannot accept responsibility for damage, injury, loss or expenses resulting from misapplication of the information herein.

* Manufacturer measured compressor capacity taken at standard -23°C/49°C (Evap/Cond) condition.

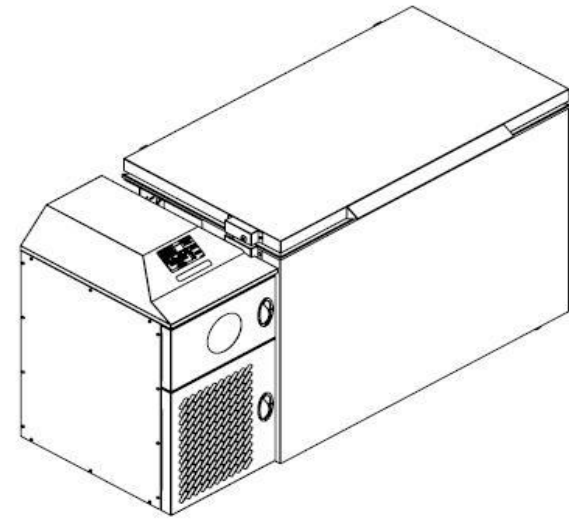
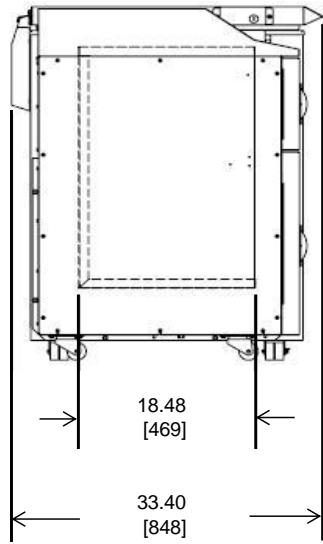

OPTIONAL BACKUP SYSTEM CONNECTOR

POWER LABEL & SWITCH

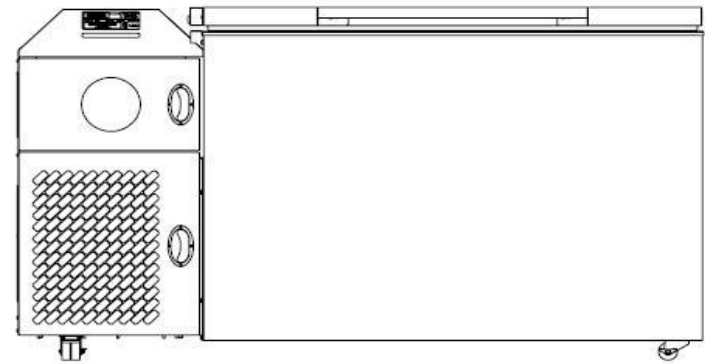
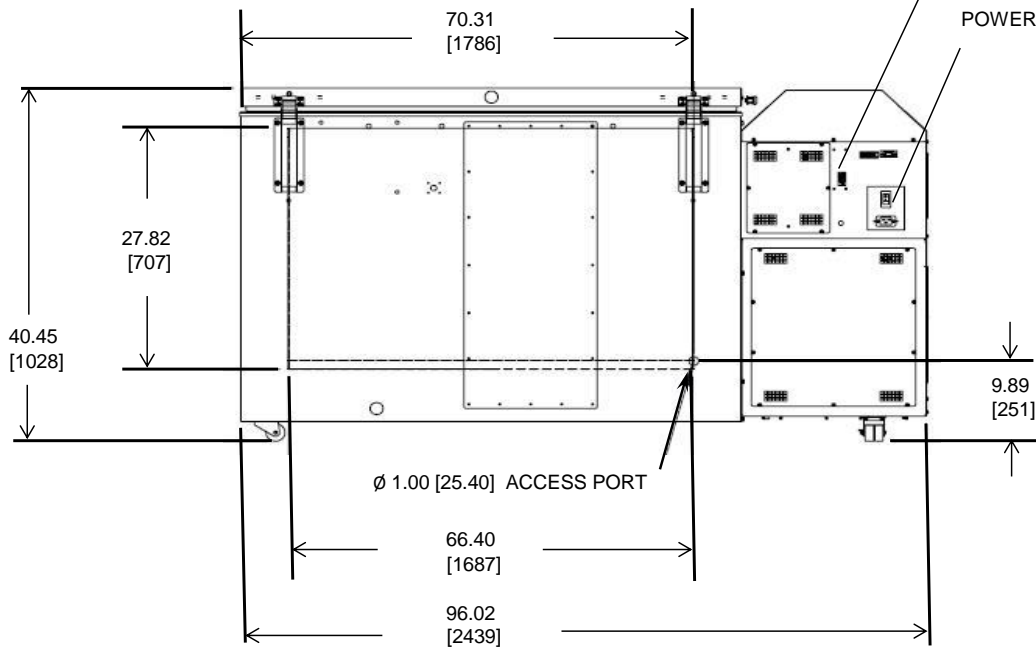

thermo
scientific

20 cuft Chest Freezer

NOTE: DUAL DIMENSION IS INCH OVER METRIC
DO NOT USE FOR ENGINEERING PURPOSES. SUBJECT TO CHANGE WITHOUT NOTICE.



Wolflabs

Wolf Laboratories Limited

www.wolflabs.co.uk

Tel: 01759 301142

Fax: 01759 301143

sales@wolflabs.co.uk



Use the above details to contact us if this literature doesn't answer all your questions.

Pricing on any accessories shown can be found by keying the part number into the search box on our website.

The specifications listed in this brochure are subject to change by the manufacturer and therefore cannot be guaranteed to be correct. If there are aspects of the specification that must be guaranteed, please provide these to our sales team so that details can be confirmed.

