

(Hotplate) Magnetic Stirrer

User Manual



MS-H-Pro+ LCD Digital Hotplate Magnetic Stirrer

MS-H-S Classic Hotplate Magnetic Stirrer

MS-Pro LCD Digital Magnetic Stirrer

MS-S Classic Magnetic Stirrer

Please read the User Manual carefully before use, and follow all operating and safety instructions!

Technical specifications and outline are subject to change without prior notice.

www.dlabsci.com



Contents

Preface	1
Service	1
Warranty	1
1. Safety Instructions	2
2. Proper Use	3
3. Inspection	4
3.1 Receiving Inspection	4
3.2 Listing of Items.....	4
4. Control.....	5
4.1 Control elements	5
4.2 Display (LCD digital model)	7
5. Trial Run.....	7
6. Function: Heating (LCD digital hotplate model).....	8
6.1 Working with external temperature sensor	9
6.2 Residual heat warning (HOT)	9
7. Stirring (LCD digital model)	9
8. Remote Control (LCD digital model).....	10
9. Faults	10
10. Maintenance and Cleaning	11
11. Associated Standards and Regulations	12
12. Specifications	13
13. Ordering Information	14

Preface

Welcome to the “(Hotplate) Magnetic Stirrer User Manual”. Users should read this Manual carefully, follow the instructions and procedures, and be aware of all the cautions when using this instrument.

Service

When help needed, you can always contact the Service Department of manufacturer for technical support in the following ways:

.

Dragon Laboratory Instruments Limited

No.31, Yu An Road, Zone B of TianZhu Airport Industrial Park, Shunyi District, Beijing, 101318 P. R. China

Tel: 86-10-85653451/52/53

Fax: 86-10-85653383

E-mail: info@dragon-lab.com

Service Hotline: 400-1100-556

Http://www.dragon-lab.com

Please provide the customer care representative with the following information:

- Serial number (on the rear panel)
- Certification
- Description of problem (i.e., hardware or software)
- Methods and procedures adopted to resolve the problems
- Your contact information

Warranty

This instrument is warranted to be free from defects in materials and workmanship under normal use and service, for a period of 24 months from the date of invoice. The warranty is extended only to the original purchaser. It shall not apply to any product or parts which have been damaged on account of improper installation, improper connections, misuse, accident or abnormal conditions of operation.

For claims under the warranty please contact your local supplier. You may also send the instrument directly to manufacturer, enclosing the invoice copy and by giving reasons for the claim.

1. Safety Instructions



Warning!

- Read the operating instructions carefully before use.
- Ensure that only trained staff works with the instrument.



Risk of burn!

- Caution when touch the housing parts and the hotplate which can reach temperature of 340 °C.
- Pay attention to the residual heat after switching off.



Protective ground contact!

- Make sure that socket must be grounded (protective ground contact) before use.

• When working wear personal safety guards to avoid the risk from:

- Splashing and evaporation of liquids
- Release of toxic or combustible gases

• Set up the instrument in a spacious area on a stable, clean, non-slip, dry and fireproof surface. Do not operate the instrument in explosive atmospheres, with hazardous

substances or under water.

- Gradually increase the speed, reduce the speed if:
 - Stirring bar breaks away due to high speed
 - The instrument is not running smoothly, or container moves on the base plate
- Temperature must always be set to at least 50°C lower than the fire point of the media used.
- Be aware of hazards due to:
 - Flammable materials or media with a low boiling temperature
 - Overfilling of media
 - Unsafe container
- Process pathogenic materials only in closed vessels.
- If the case of the stirrer bar is PTFE, please note:
 - Elemental fluorine, three fluoride and alkali metals will corrode the PTFE and Halogen alkanes make it expansion at room temperature
 - Molten alkali, alkaline earth metals or their solution, as well as the powder in second and third ethnic of the Periodic Table of Elements will have chemical reaction with PTFE when temperature reaches 300 ~ 400 °C .
- Check the instrument and accessories prior to each use. Do not use damaged components. Safe operation is only

guaranteed with the accessories described in the “Accessories” chapter. Accessories must be securely attached to the device and can not come off by themselves. Always disconnect the plug before fitting accessories.

- When the external temperature sensor needed, the tip of the measuring sensor must be at least 5-10mm from vessel bottom and wall.
- The instrument can only be disconnected from the main power supply by pulling out the main or the connector plug.
- The voltage stated on the label must correspond to the main power supply.
- Ensure that the main power supply cable does not touch the hotplate. Do not cover the device.
- The instrument may only be opened by experts.
- Keep away from high magnetic field.

2. Proper Use

The instrument is designed for mixing and/or heating liquids in schools, laboratories or factories.

- Observe the minimum distances between the devices, between the device and the wall and above the assembly (min. 100 mm)

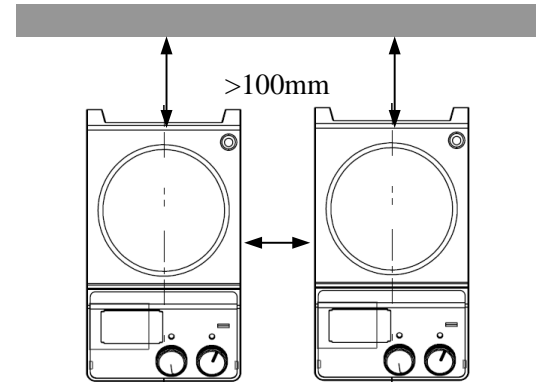

Figure 1

This device is not suitable for using in residential areas or other constraints mentioned in Chapter 1.

3. Inspection

3.1 Receiving Inspection

Unpack the equipment carefully and check for any damages which may have arisen during transport. Please contact manufacturer/supplier for technical support.



Note:

If there is any apparent damage to the system, please do not plug it into the power line.

3.2 Listing of Items

The package includes the following items:

Items	Qty
Main unit	1
Power cable	1
Stirrer bar	1
User Manual	1

Table 1

4. Control

4.1 Control elements

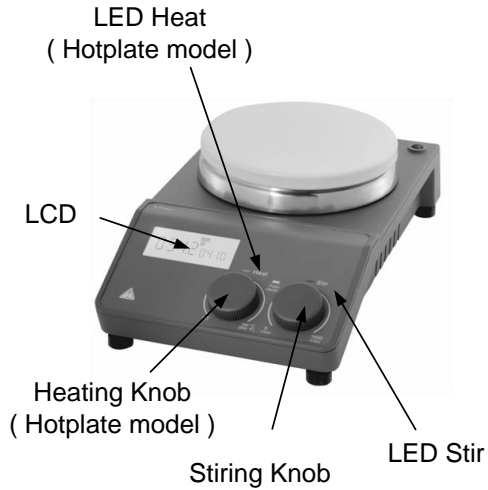

Figure 2 LCD Digital model

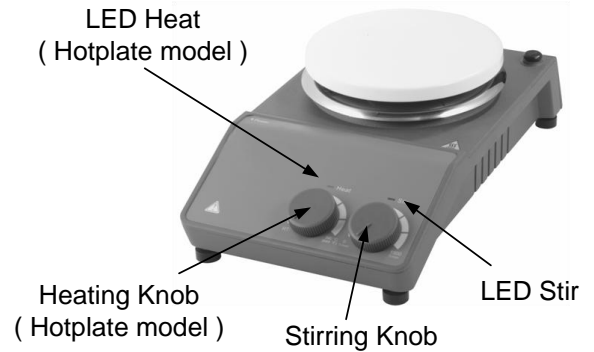

Figure 3 Classic model

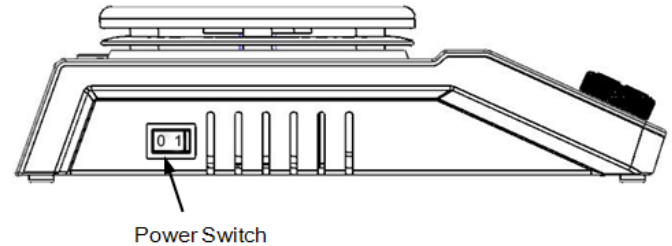

Figure 4

	Items	Descriptions
LCD Digital model	Stirring knob Stir	Set the rated rotary speed. The function “Stirring” is switched ON or OFF via push ON/OFF the knob.
	Heating knob Heat (Hotplate model)	Set the rated temperature. The function “heating” is switched ON or OFF via push ON/OFF the knob.
	LCD	LCD displays the real working state and all settings.
	LED Heat (Hotplate model)	When the heating function is switched ON, the LED Heat is lit.
	LED Stir	When the stirring function is switched ON, the LED Stir is lit.
	Power Switch	Switch ON or OFF the instrument.
Classic model	Stirring knob Stir	Set the rated rotary speed in the safe stirring range from 0 to 1500 rpm. The function “Stirring” is switched ON or OFF via the knob.
	Heating knob Heat (Hotplate model)	Set the rated temperature in the safe temperature range from room temperature to 340 °C. The function “heating” is switched ON or OFF via the knob.
	LED heat (Hotplate model)	When the heating function is switched ON, the LED Heat is lit.
	LED Power	When the device is switched ON, the LED power is lit.
	Power switch	Switch ON or OFF.

Table 2

4.2 Display (LCD digital model)

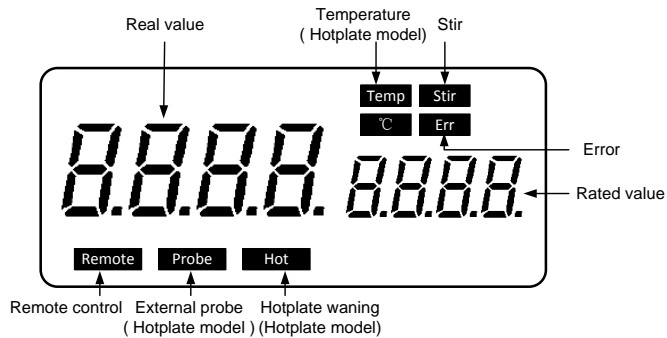

Figure 5

Err	Display in case of error happening.
Rated value/Real value	Display value in case of heating or stirring function switching ON.

Table 3



Note:

If both heating and stirring functions have been started at the same time, heating function always has higher priority. If in this case speed is changed via the stirring knob, it displays stirring speed and reverses to temperature in the duration of 5 seconds.

Characters	Descriptions
Temp and °C	Display temperature when the heating function is switched ON.
Stir	Display stirring state when the stirring function is switched ON.
Hot	Display hot warning if the heating plate temperature is above 50 °C after switching OFF the heating function.
Probe	Display when using external probe.
Remote	Display in case of remote control.

5. Trial Run

- Make sure the required operating voltage and power supply voltage match.
- Ensure the socket must be properly grounded.
- Plug in the power cable, ensure the power is on and begin initializing.
- Add the medium into the vessel with an appropriate stirring bar.
- Place vessel on the work plate.

- Set the target stirring speed and begin.
- Observe the stirring bar and LCD display (digital model).
- Set the target temperature and start heating.
- Observe the real temperature on LCD display (digital model).
- Stop the heating and stirring functions.

If these operations above are normal, the device is ready to operate. If these operations are not normal, the device may be damaged during transportation, please contact manufacturer/supplier for technical support.



Warning !

Forbid to transfer the vessel when the instrument working.

6. Function: Heating (LCD digital hotplate model)

The device is controlled by digital temperature control technology, which has two separate safe circuits. The hotplate is kept at a constant temperature by a digital control circuit. The hotplate temperature can also be monitored from a separate, adjustable safe circuit. The two temperature sensors (PT1000) internal for temperature control are built into the hotplate. The single external

PT1000 can monitor the temperature of sample.

- Plug in the external PT1000.
- Set the temperature via rotating the temperature control knob slowly to the target value.
- When the heating function is switched on, the LED “Heat” will light up and the LCD will display the real temperature.
- The rated temperature will be displayed on the right-hand side of the LCD as well as **Temp** and **°C** characters.
- The heating function is switched on or off by pushing heating knob.

Instrument is turned on for the setting zone temperature setting when the last shutdown temperature, the common case, set the heating temperature display the actual temperature may have the following differences:

- Hotplate center and outer edge.
- The sample container and the container.

In order to ensure the accuracy of the temperature inside the container, please use the external temperature sensor PT1000.

6.1 Working with external temperature sensor

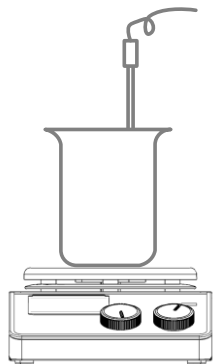

Figure 6

The external temperature sensor PT1000 is the manufacture's standard accessory. If the sensor is plugged in, "Probe" will be shown on the digital display to indicate the sensor is operating. The setting value of external temperature sensors and actual temperature are displayed. Safe circuit controls hotplate temperature.

Comparing with the temperature control of the hotplate, the external temperature sensor can control the medium's temperature more precisely.

6.2 Residual heat warning (HOT)

In order to prevent the risk of burns from a hotplate, digital hotplate has a residual heat warning function. When the heating function is switched off and the heating plate temperature is still above 50°C, "Hot" will flash to warn that there is a hazard of burns from the hotplate. When the hotplate temperature drops to below 50°C, the unit will automatically switch off. If users want to turn off the LCD immediately, just pull out the plug directly. When the plug is pulled out, the residual heat warning function cannot be run.

7. Stirring (LCD digital model)

The function "stirring" is switched on or off via rotating stirring knob. The speed is set on the knob (100 to 1500 rpm in steps of 10 rpm). When both of function heating and stirring are switched on and those above operations are done, the LCD will shift to the speed value and come back to the temperature value in about 5 seconds.

8. Remote Control (LCD digital model)

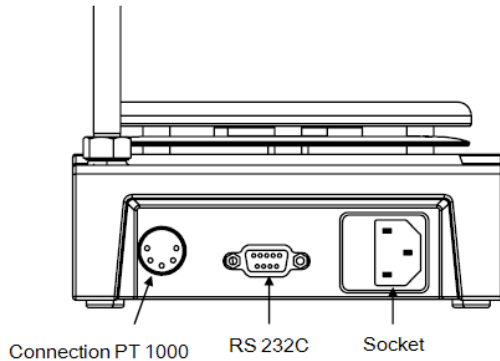

Figure 7

The unit can be controlled from an external PC (using the dedicated software) via the RS232C serial interface fitted to the unit. Data communication from laboratory instrument to computer is only possible on demand of the computer.

- The functions of the interface lines between laboratory instrument and automation system are selected from the specified signals of the EIA-standard RS232C, corresponding with DIN66020 Part 1. The allotment of the bushing can be taken from Figure 7
- Transmission method: Asynchronous signal

transmission in start-stop-operation.

- Mode of transmission: Fully Duplex. 1 start bit; 7 character bits; 1 parity bit [straight (even)]; 1 stop bit.
- Transmission speed: 9600 bit/s
- Start remote control knob LCD display “ Remote ”.



Note:

Forbid to insert or remove the RS232C communication line when switch on!

9. Faults

- Instruments can't be power ON
 - Check whether the power line is unplugged
 - Check whether the fuse is broken or loose
- Fault in power on self test
 - Switch OFF the unit, then switch ON and reset the instruments to factory default setting.
- Stir speed cannot reach set point
 - Excessive medium viscosity may cause abnormal speed reduction of the motor
- Unit cannot be powered off when switched off.
 - Check if the residual heat warning function is still ON and hotplate temperature is above 50°C (the LCD still work and “Hot” flash).

If these faults are not resolved, please contact manufacturer/supplier.

10. Maintenance and Cleaning

- Proper maintenance can keep instruments working properly and lengthen its lifetime.
- Do not spray cleanser into the instrument when cleaning.
- Unplug the power line when cleaning.
- Only use recommended cleansers:

Dyes	Isopropyl alcohol
Construction materials	Water containing tenside / Isopropyl alcohol
Cosmetics	Water containing tenside / Isopropyl alcohol
Foodstuffs	Water containing tenside
Fuels	Water containing tenside

- Before using other method for cleaning or decontamination, the user must ascertain with the manufacturer that this method will not harm the instrument. Wear the proper protective gloves during cleaning of the instrument.



Note:

- Electronic device can not clean with cleanser.
- If you require maintenance service, must be cleaned the instrument in advance to avoid pollution of hazardous substances, and to send back into original packing.
- If the instrument will not use for a long time, please switch off and place in a dry, clean, room temperature and stable location.

11. Associated Standards and Regulations

Construction in accordance with the following safety standards:

EN 61010-1

UL 3101-1

CAN/CSA C22.2(1010-1)

EN 61010-2-10

Construction in accordance with the following EMC standards:

EN 61326-1

Associated EU guidelines:

EMC-guidelines: 89/336/EWG

Instrument guidelines: 73/023/EWG

interference when the equipment is operated in a commercial environment. This equipment generates, uses, and can radiate radio frequency energy and, if not installed and used in accordance with the instruction manual, may cause harmful interference to radio communications. Operation of this equipment in a residential area is likely to cause harmful interference in which case the user will be required to correct the interference at his own expense.

Changes or modifications not expressly approved by the party responsible for compliance could void the user's authority to operate the equipment.

NOTE: This equipment has been tested and found to comply with the limits for a Class A digital device, pursuant to Part 15 of the FCC Rules. These limits are designed to provide reasonable protection against harmful

12. Specifications

Items	Specifications	
	Digital model	Classic model
Voltage [VAC]	100-120/200-240	100-120/200-240
Frequency [Hz]	50/60	50/60
Power [W]	*550 50	*530 30
Stirring point position quantity	1	1
Max. stirring quantity (H ₂ O) [l]	20	20
Max. magnetic bar [L×∅, mm]	80×10	80×10
Motor type	DC brushless motor	
Max. power input of motor [W]	18	18
Max. power output of motor [W]	10	10
Speed range [rpm]	100-1500, increment: 10	0-1500
Rotary speed display	LCD	Scale

Plate material	Stainless steel/Ceramic coated	
Dimensions of workplate (mm)	∅ 135	∅ 135
*Heating power [W]	500	500
*Temperature range [°C]	RT-340, increment: 1	RT-340
*Temperature display [°C]	LCD	Scale
*Temperature display accuracy [°C]	±0.1	-
*The safe temperature of hotplate [°C]	360	100-350
*Temperature sensor in medium	PT1000	-
*Control accuracy of heating temp with temp sensor [°C]	±0.2	-
*Residual heat warning	50°C	-

Dimensions (mm)	280×160×85	
Weight [kg]	2.8	2.8
Permitted ambient temperature [°C]	5-40	
Permitted relative humidity	80%	
Protection class acc. to DIN 60529	IP42	
RS232 interface	Yes	N/A

*Hotplate model

Table 4

13. Ordering Information

Cat No.	Descriptions
861442017777	MS-H-Pro ⁺ Digital Hotplate Magnetic Stirrer, Ceramic Coated Hotplate, USA plug, 100V-120V, 50Hz/60Hz
8614242127777	MS-H-Pro ⁺ Digital Hotplate Magnetic Stirrer, Ceramic Coated Hotplate, Cn plug, 200V-240V, 50Hz/60Hz
861442227777	MS-H-Pro ⁺ Digital Hotplate Magnetic Stirrer, Ceramic Coated Hotplate, Euro plug, 200V-240V, 50Hz/60Hz
861242327777	MS-H-Pro ⁺ Digital Hotplate Magnetic Stirrer, Ceramic Coated Hotplate, UK plug, 200V-240V, 50Hz/60Hz
811121027777	MS-H-S Classic Hotplate Magnetic Stirrer , ceramic coated hotplate, USA plug, 100V-120V, 50Hz/60Hz
811121017777	MS-H-S Classic Hotplate Magnetic Stirrer , ceramic coated hotplate, Cn plug, 200V-240V, 50Hz/60Hz
811121057777	MS-H-S Classic Hotplate Magnetic Stirrer , ceramic coated hotplate, Euro

Cat No.	Descriptions
	plug, 200V-240V, 50Hz/60Hz
811121067777	MS-H-S Classic Hotplate Magnetic Stirrer , ceramic coated hotplate, UK plug, 200V-240V, 50Hz/60Hz
811113157777	MS-Pro LCD Digital Magnetic Stirrer, ceramic coated hotplate, USA plug, 100V-120V, 50Hz/60Hz
811113147777	MS-Pro LCD Digital Magnetic Stirrer, ceramic coated hotplate, Cn plug, 200V-240V, 50Hz/60Hz
811113077779	MS-Pro LCD Digital Magnetic Stirrer, ceramic coated hotplate, Euro plug, 200V-240V, 50Hz/60Hz
811113167777	MS-Pro LCD Digital Magnetic Stirrer, ceramic coated hotplate, UK plug, 200V-240V, 50Hz/60Hz
811111127777	MS-S Classic Magnetic Stirrer, ceramic coated hotplate, USA plug 100-240V, 50Hz/60Hz
811111117777	MS-S Classic Magnetic Stirrer, ceramic coated hotplate, Cn plug, 100-240V,

Cat No.	Descriptions
	50Hz/60Hz
811111087777	MS-S Classic Magnetic Stirrer, ceramic coated hotplate, Euro plug 100-240V, 50Hz/60Hz
811111137777	MS-S Classic Magnetic Stirrer, ceramic coated hotplate, UK plug, 100-240V, 50Hz/60Hz
Accessories	
18900016	PT1000-A Temperature sensor for digital hotplate model, used for MS-H-Pro ⁺ , MS7-H550-Pro & MS7-H550-S, 230mm
18900136	PT1000-B Glass coated temperature sensor for digital hotplate model, used for MS-H-Pro ⁺ , MS7-H550-Pro & MS7-H550-S, 230mm
18900017	Support clamp of PT1000
18900001	MS 135.1 Carrier plate, used with MS 135.2-5
18900002	MS135.2 Red quarter pie, 11 holes, 4 ml reaction vessel, Ø15.2mm, 20mm

Cat No.	Descriptions
	depth
18900003	MS135.3 Purple quarter pie, 4 holes, 20 ml reaction vessel, Ø28mm, 24mm depth
18900004	MS135.4 Blue quarter pie, 4 holes, 30 ml reaction vessel, Ø28mm, 30mm depth
18900005	MS135.5 Black quarter pie, 4 holes, 40 ml reaction vessel, Ø28mm, 43mm depth
18900048	MS135.6 Green quarter pie, 6 holes, 8ml reaction vessel, Ø17.75mm, 26mm depth
18900049	MS135.7 Golden quarter pie, 4 holes, 16ml reaction vessel, Ø21.6mm, 31.7mm depth
18900080	Reaction block for 50ml round bottom flask(one flask capacity)
18900081	Reaction block for 100ml round bottom flask(one flask capacity)
18900082	Reaction block for 250ml round bottom flask(one flask capacity)

Cat No.	Descriptions
18900083	Reaction block for 500ml round bottom flask(one flask capacity)
18900006	Stirrer bar (10mm x 6mm) , 1pc/pk
18900007	Stirrer bar (15mm x 8mm) , 1pc/pk
18900008	Stirrer bar (20mm x 8mm) , 1pc/pk
18900009	Stirrer bar (25mm x 8mm) , 1pc/pk
12500005	Stirrer bar (30mm x 6mm) , 1pc/pk
18900011	Stirrer bar (40mm x 8mm) , 1pc/pk
12500004	Stirrer bar (50mm x 8mm) , 1pc/pk
18900013	Stirrer bar (65mm x 8mm) , 1pc/pk
18900014	Stirrer bar (80mm x 13mm), 1pc/pk
18900015	Stirrer bar remover, 1pc/pk
18900018	F100 protective cover, for non-hotplate model
18900019	F101 protective cover, for hotplate model

Table 5



DLAB Scientific Instrument Inc.

2311 E. Locust Court, Ontario, CA 91761 United States.

Office: +1-747-230-5179

Fax: +1-909-230-5275

Sales contact: info@dlabsci.com

Service contact: service@dlabsci.com

www.dlabsci.com