



14500 Coy Drive, Grass Lake, Michigan 49240
734-475-2200 E-mail: sales@coylab.com
www.coylab.com

Polymer Anaerobic Chamber, Instruction Manual

COY Anaerobic Chamber

Rigid Glove Boxes with Purge Airlock (Gloved Option)

OWNER'S MANUAL

	<u>Page #</u>
1.0 DESCRIPTION	2
WARNING	2
1.1 WARRANTY	2
1.2 GENERAL INFORMATION	3
1.3 CHAMBER ASSEMBLY & COMPONENT PLACEMENT	3-7
2.0 PURGING THE CHAMBER & GETTING STARTED	8
3.0 OPERATION OF COMPONENTS	
3.1 STANDARD ACCESSORIES	11
1. AUTOMATIC PURGE AIRLOCK	
2. FAN BOX (Heated & Unheated)	
3. GAS LEAK DETECTOR	
4. GAS PRESSURE REGULATOR	
5. Stak-Pak (Catalyst & Desiccant)	
3.2 OPTIONAL EQUIPMENT	15
1. OXYGEN/HYDROGEN ANALYZER	
2. INCANDESCENT FLAMING DEVICE	
3. ATMOSPHERE FILTER	
5. GAS INJECTION SYSTEM	
6. ARM PORT PLUGS	
7. AUTOMATIC PURGE AIRLOCK	
4.0 THEORY OF DESIGN	
4.1 PALLADIUM CATALYST/GAS REACTION	17
4.2 OXYGEN ENTERING THROUGH AIRLOCK	17
4.3 CONTROLLING MOISTURE	18
5.0 CARE AND MAINTENANCE	
5.1 CARE OF POLYCARBONATE VIEWING SCREEN	19
5.2 CARE OF GLOVES/NEOPRENE SLEEVES	20
5.3 DETECTING LEAKS	21
6.0 ANSWERS TO FREQUENTLY ASKED QUESTIONS	21

1.0 DESCRIPTION

Warning

Do not use **PURE** hydrogen in establishing your chamber environment. Use only pre-mixed gases.

The use of pure hydrogen, or pre-mixed gases with a hydrogen content of greater than 5%, may cause an explosive mixture to exist in your chamber.

1.1 WARRANTY

The electronic components contained in this chamber are warranted against defects in material and workmanship during the first 12 months after original date of shipment.

The factory will, at its option, repair or replace defective materials within the above periods at no charge for parts and labor.

All returns or exchanges must first be authorized by Coy Laboratory Products, Inc.

Phone: 734-475-2200

Fx: 734-475-1846

E-mail: sales@coylab.com

Coy Laboratory Products, Inc.

14500 Coy Drive

Grass Lake, MI 49240

The responsibility of Coy Laboratory Products, Inc., is limited to the purchase price of this product, and Coy Laboratory Products, Inc. will not be responsible for any consequential damages.

This warranty does not cover damage in shipment or damage as a result of improper use or maintenance of this product. This warranty does not cover damages caused by excessive line transients on the AC supply line.

1.2 GENERAL OVERVIEW

- 1.2.1 This manual is designed to provide you with basic knowledge of a Coy Polymer Glove Box and the components supporting it for an anaerobic application with a purge airlock. The manual provides insight on how to assemble, operate, and maintain the glove box. We strongly recommend that all laboratory personnel and glove box users read the manual to become familiar with assembly, operation, care, maintenance and theory of anaerobic conditions.
- 1.2.2 *The Polymer Glove Box* is available in three, four, or five foot lengths and is constructed of Polycarbonate (Lexane) or optional UV Resistant Acrylic. The 3 ft. length model has two arm ports. The 4 ft. Glove Box is equipped with 3 glove ports. The 5 ft. length has 4 arm ports. The Polymer Glove Box comes equipped with a large removable rear panel to allow introduction of large equipment prior to establishment of chamber atmosphere. The Airlock is located on the left hand side of the glove box unless otherwise requested.
- 1.2.3 A Fan Box is supplied with the Chamber (two in the 2 person Aluminum Glove Box) to ensure a uniform anaerobic environment. The Fan Box circulates the Chamber's atmosphere through palladium catalyst to remove oxygen. It should be noted here that **HYDROGEN** must be present in order for the palladium catalyst to properly remove oxygen (see section 2.0 Theory of Design for more details). The Palladium Catalyst is contained within a COY Stak-Pak that sits conveniently on top of the fan box. These Fan Boxes may be laid length wise or stood on end with the fan cage facing up.

1.3 CHAMBER ASSEMBLY

1.3.1 Before shipment all parts have been assembled and tested for leaks.

For Set Up:

1. **Packing material.**

The Gloves, Interior Plug Strip, Ball Valve, and Automatic Pressure Relief Valve are installed at the factory. All other items should be removed from the interior of the glove box and inspected. The following materials should be provided with your Basic Glove Polymer Anaerobic Chamber:

- *Gas Regulator for a mixed gas with connections already assembled.
- T connector
- 6 ty wrap strips
- 2 Female quick disconnect fittings
- 2 Stak paks
- 1 pair of rubber gloves
- Diaphragm Top
- 1 Catalyst Fan Box (3 & 4 ft. units) 2 Catalyst Fan Boxes (5 ft. units)
- ¼" Ball Valve with male with quick disconnect fitting
- Pressure Relief Valve
- Removable Rear Panel
- 6 Outlet interior Plug Strip sealed through Feed Thru-Adaptor

NOTE: Units supplied outside the U.S. and Canada will require an adaptor or a different gas regulator for correct tank connection.

Assembling & Installing tubing to fittings:

2. You will notice that the tubing and fittings come connected only to the gas regulator. **You will need to cut this tubing and attach it to the additional fittings;** T connect to the tank or tanks of gas, Airlock, and any other accessory. Use the instructions listed below and figure #2 and #3 to attach the tubing to the supplied fittings.
 - A. Place a female fitting on each end of tubing. (male fittings are installed on the equipment at the factory)
 - B. Place 2 ty-wraps around the hose barb on the female fittings and pull them as tight as possible.
 - C. Cut off excise ty-wrap.
 - D. Insert Female fitting connected to the tubing to the Male fitting on the Glove Box Ball Valve. When fitting is seated correctly, you will hear a click.

For the Tee Fitting the same instructions apply (figure #3)

To disconnect the tubing, depress the silver tab on the male fitting and separate.

Figure # 2 Tubing connection to Quick Disconnect Fitting

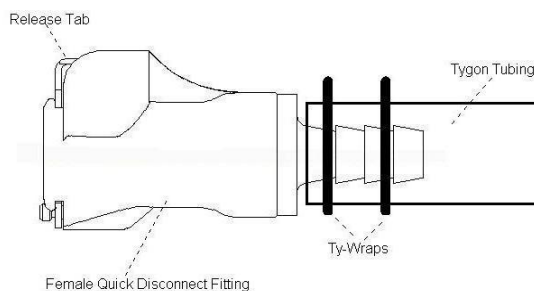
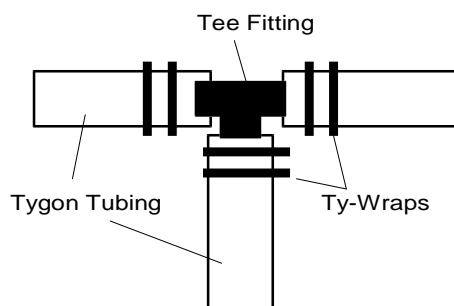

Figure # 3 Tubing connection to Tee Fitting



1.3.2 Plumbing the Glove Box, Airlock, and Gas Tank Supplies

1. Using the tygon tubing supplied attach the gas mix regulator (supplied) to your gas mix tank and connect to a supplied $\delta T\ddot{o}$ fitting. From the $\delta T\ddot{o}$ Fitting connect one end to the Manual Ball Valve on the airlock and the other end to the Manual Ball Valve on the Glove Box (see figure #4/ page 6). The gas regulator should be adjusted to 15 psi (pounds per square inch) output.

If you have purchased the Automatic Purge Airlock option then the gas line will connect to the Gas Inlet of this accessory. Then a length of tubing will have to be connected from the Gas Outlet to the Manual Ball Valve on the airlock (see figure #5)

Figure #4 Glove Box Gas Connections for Manual Airlock

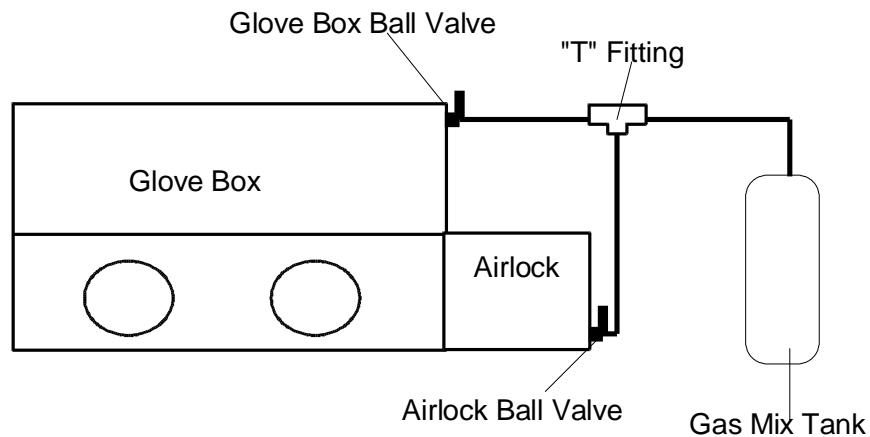
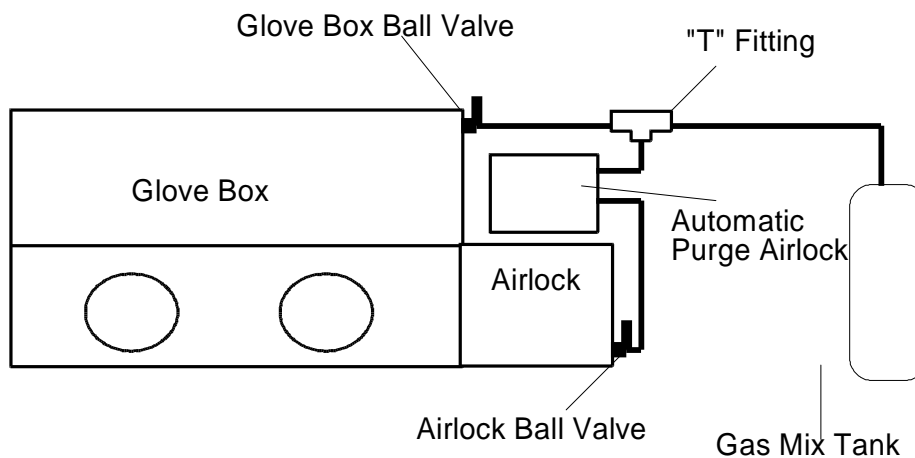

Figure #5 Glove Box Gas Connections for Automatic Airlock



5. Large equipment will be placed inside the chamber through the removable rear panel (polymer glove box). See figure # 6 for typical floor glove box floor plans

NOTE: If the COY Model 10 Gas Analyzer has been purchased then a special shelf dedicated to the analyzer has been included in the chamber (not shown in floor plan drawings)

Figure #6 Glove Box Floor Plans

3 ft. Polymer Glove Box

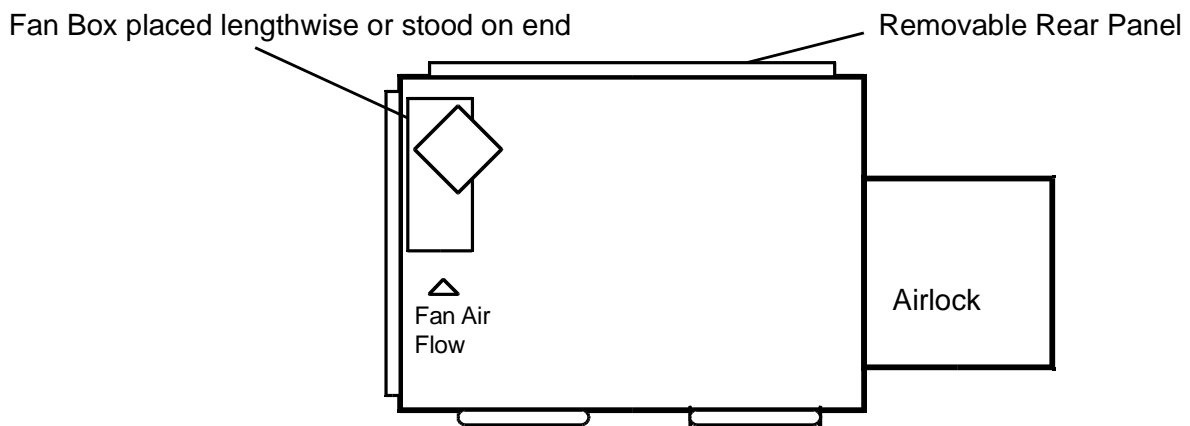

4 ft. Polymer Glove Box

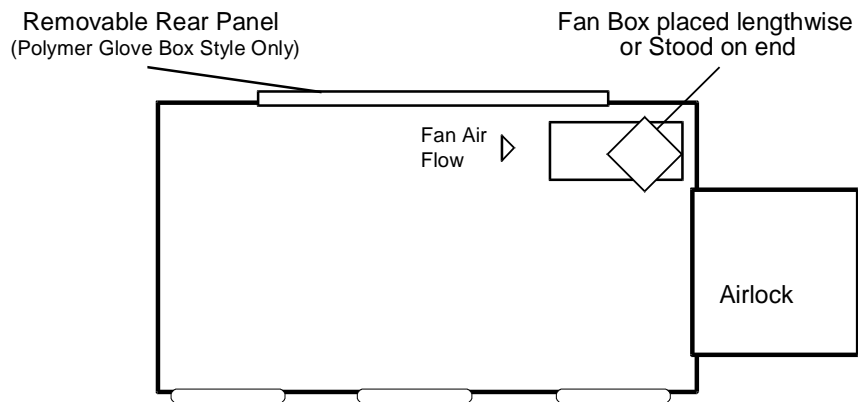
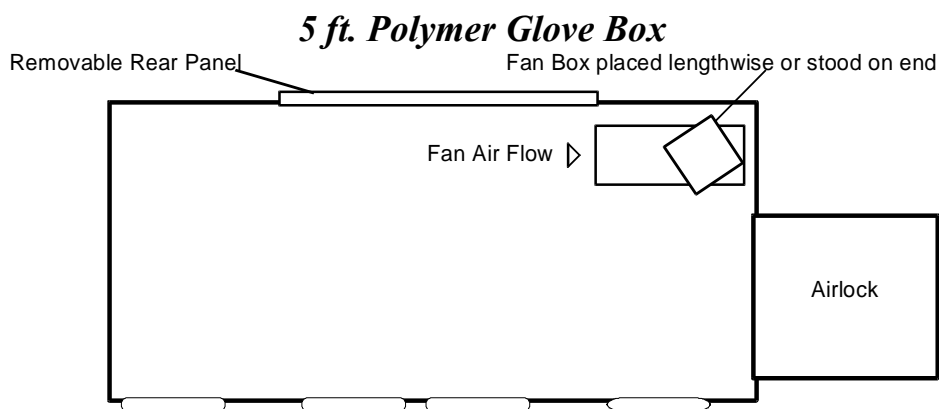

Figure #6 Glove Box Floor Plans continued



2.0 Purging the Chamber & Getting Started

2.1 *This section will explain how to purge the Chamber and establish an anaerobic environment.*

NOTE! DO NOT INTRODUCE CATALYST INTO THE CHAMBER UNTIL THE PURGE OPERATION IS COMPLETE.

1. Plug the Fan boxes into the interior plug strip provided. If the fan boxes are the heated models adjust the temperature set point (*see heated fan box manual*) so that the heating elements **DO NOT TURN ON** during the initial set up procedure.
2. Close the large door or removable rear panel. Open the inner airlock door and close the outside airlock door.

NOTE: If you purchased Arm Port Plugs they should not be placed in the Arm Ports during this initial purge as the interior of the gloves need to be purged as well. During the purge the gloves will stick straight out this is normal.

3. Make sure the pressure relief valve is not blocked. You can now begin to purge the glove box with your background gas using the Glove Box Ball Valve.
4. The flow rate is determined by your gas regulator (DO NOT EXCEED 15 PSI.). Using the chart below Purge the chamber for the set length of time determined by your glove box size.

WARNING: It is extremely important that only a pre-mixed gas of 5% H₂ is used

for this procedure. Failure to do so will result in an explosive gas mix inside your glove box. Do not introduce the Stak-Pak catalyst into the chamber at this time.

Manual Purge

<i>Glove Box Size</i>	<i>Purge Time at 15 psi</i>	<i>Estimated % of O₂ left in Chamber</i>
<i>3ft. Polymer Glove Box</i>	<i>300 seconds</i>	<i>1.9%</i>
	<i>400 seconds</i>	<i>.8%</i>
	<i>500 seconds</i>	<i>.1%</i>
<i>4ft. Polymer Glove Box</i>	<i>360 seconds</i>	<i>2.5%</i>
<i>5ft. Polymer Glove Box</i>	<i>480 seconds</i>	<i>4%</i>

NOTE: You must time this operation manually. When finished turn the manual ball valve completely off.

During the chamber purge you will notice the diaphragm top will inflate to its maximum height, this is normal and will not harm the vinyl. The incoming gas will push out existing chamber atmosphere (O₂) through a Pressure Relief Valve mounted on the back wall of the chamber on the opposite end from the Airlock.

2.1.2 Option for Initial Purge

You may chose to use a straight nitrogen tank for this initial set-up to save on cost. Connect the glove box ball valve to the nitrogen tank and purge for the same times as listed above. After this initial Purge reconnect the Gas Mix Tank and introduce the H₂ Gas Mix to get the appropriate amount of H₂ by using the following chart for purge times.

Glove Box Size	Purge Time at 15 psi (pounds per square inch)
3 ft. Polymer Glove Box (10.5 cu. ft./297 liters)	120 seconds (2 minutes)
4 ft. Polymer Glove Box (14.5 cu. ft./410 liters)	150 seconds (2.5 minutes)
5 ft. Polymer Glove Box (18 cu. ft./509 liters)	180 seconds (3 minutes)

These times assume the chamber to be empty of tubes and Petri dishes and any other equipment.

NOTE: If you have purchased the Model 10 Gas Analyzer you may simply purge the glove box with the gas mix until you achieve desired gas mix. A 5% H₂ mix tank will achieve approximately 3.5 to 4.0%.

2.1.3 Final Glove Box Set-Up Instructions

1. With inner airlock door closed open the outer airlock door and place one catalyst Stak-Pak for every fan box inside the airlock. Close the outside door and purge the airlock to desired time (see section 3.1 on page 8).
2. After the airlock purge is completed open the inner airlock door, and bring the catalyst Stak-Pak (s) into the glove box. Place the Stak-Pak (s) on the tray holder of the Catalyst Fan Box.

IF YOU ARE USING CATALYST THAT IS NOT CONTAINED IN A COY STAK-PAK, MAKE SURE IT DOES NOT SPILL ONTO THE CHAMBER FLOOR.

When palladium catalyst is introduced to an environment rich in oxygen and hydrogen the palladium coated pellets generate heat as the 3 components (Catalyst, oxygen and hydrogen) react with each other.

3. After the introduction of the catalyst you may observe a build up of condensation on the chamber walls, this is a signal that everything is working properly. If the moisture continues to collect you may require desiccant stak-paks to remove the excess moisture. If the catalyst becomes extremely hot or glowing red, this is a sign that the system was not properly purged. Immediately remove the catalyst from the glove box and purge the chamber for a few extra minutes.
4. After one hour repeat the gas mix purge in the chamber (at least 2 minutes) see to refresh the hydrogen consumed during the initial set-up.,
5. During the next 24-48 hours, you should monitor the oxygen content in your Chamber using Coy's Oxygen/ Hydrogen Analyzer. After the first 24 hours of operation, perform another 2 minute purge with the gas mix, to allow more hydrogen to enter the Chamber's atmosphere as a great deal of the hydrogen is consumed in removing the initial levels of oxygen in the glove box. If the Chamber is left unattended for several days, it may lose anaerobic condition due to lack of hydrogen. For this reason, Coy recommends using the Oxygen/Hydrogen Analyzer to monitor your Chambers hydrogen content. The COY Automatic Gas Injection System (part #8100-110) can also help maintain proper hydrogen levels automatically by purging in your gas mix at pre-set intervals (fully adjustable).
6. The catalyst Stak-Pak should be rejuvenated at least once a week for it to maintain its usefulness. If you have a very busy chamber, you will find that you will need to rejuvenate the Catalyst more frequently perhaps two or three times a week. To rejuvenate place the Catalyst in an oven and bake at 120°-200° C for 2 hours. This procedure drives off the moisture that gathers on the individual pellets of catalyst.

NOTE: After the initial set-up you should place fresh catalyst in the chamber and

rejuvenate the catalyst stak-paks you started with as these will be saturated with moisture from the start up procedure.

13.2.0 Daily/Weekly Maintenance

The System must have a hydrogen gas content to function as O₂ is continuously entering the chamber by diffusion and other means (See Section 4.0 for Theory of Design). The purging the airlock does bring some hydrogen into the chamber but this is not always enough to maintain proper H₂ levels (>1%). Therefore the following procedures are needed to maintain the anaerobic conditions;

1. Every 5-10 days remove catalyst Stak-Pak inside the chamber and replace with the freshly rejuvenated Catalyst Stak-Pak.

NOTE: To regenerate place in an oven at 125-200 °C for two hours.

2. Once the fresh Catalyst is placed back in the Catalyst Fan Box purge the system with fresh gas mix to refresh hydrogen levels. If you have purchased the COY Model 10 Analyzer you can simply purge the system until the Analyzer H₂ reading is between 3-4%. If not use the chart below as an estimate on length of the gas purge based on your chamber size.

Glove Box Size	Purge Time at 15 psi <i>(pounds per square inch)</i>
3 ft. Polymer Glove Box (10.5 cu. ft./297 liters)	120 seconds (2 minutes)
4 ft. Polymer Glove Box (14.5 cu. ft./410 liters)	150 seconds (2.5 minutes)
5 ft. Polymer Glove Box (18 cu. ft./509 liters)	180 seconds (3 minutes)

NOTE: Due to size, volume differences and various workloads these instructions should only be used as guidelines as your chamber may require more or less time and frequency of purges.

3.0 OPERATION OF COMPONENTS

This section will briefly describe the operation of both standard and optional equipment that may have been supplied with your Chamber. Standard Equipment are items included in the Chamber package. Such as:

1. PURGE AIRLOCK (manual version is standard Automatic version is optional)
2. FAN BOXES (Heated & Unheated)
3. GAS PRESSURE REGULATORS
4. GAS LEAK DETECTOR
5. STAK PAKS (Desiccant & Catalyst)

Optional equipment are items not included in the Chamber package, but must be specified. Such as:

1. OXYGEN/HYDROGEN ANALYZER
2. INCANDESCENT FLAMING DEVICE
3. ARM PORT PLUGS
4. ATMOSPHERE FILTER
5. GAS INJECTION SYSTEM

NOTE! For more complete operating instructions, please read the enclosure which comes with each piece of equipment. The following abbreviated instructions are for convenient reference only.

3.1 STANDARD EQUIPMENT

1. PURGE AIRLOCK

The Purge Airlock establishes a low oxygen concentration in the transfer chamber through a purge procedure prior to entrance into the glove box. Purge times are determined by flow rates and desired Oxygen levels.

Manual Purge Airlock

Time	Purge Rate	Estimated O ₂ Concentration Entering Main Chamber in PPM (Parts Per Million)
20 seconds	15 psi	1470 ppm
30 seconds	15 psi	575 ppm
40 seconds	15 psi	200 ppm
60 seconds	15 psi	20 ppm

NOTE: Because the oxygen concentration is higher in the airlock than in the glove box, an oxygen gradient is created. Oxygen levels are greatest at the airlock door and becoming progressively less as the distance from the door increases.

2. FAN BOX (Heated & Unheated)

Fan Boxes circulate the Chamber's atmosphere through palladium catalyst, which, in the presence of hydrogen, removes oxygen. The Fan Boxes perform other functions as well, such as provide a homogeneous mix of gases and temperature gradient within the Chamber, which is important. If your Chamber is equipped with 1 Fan Box, it should be placed near the airlock with the fan cage facing the center of the Chamber. If the Chamber has 2 Fan Boxes, they should be placed at opposite ends of the Chamber with the fan cages facing toward the center of the Chamber. The Fan Boxes' efficiency decreases if the fan cage faces the wall of the Chamber disrupting proper air flow.

NOTE: the Fan Boxes are not equipped with cooling devices and cannot control the Chamber below room temperature. Following are operating procedures for the heated and unheated Catalyst Boxes.

HEATED FAN BOXES

The heated Fan Box consists of a power switch, 2 heating cones, and a variable controlled thermostat with digital display and temperature probe. The Heated Fan Box can maintain the Chamber's temperature from +4 ambient to about 40° Celsius (note optional High Range ability available up to 65° C). Before operating the Fan Box, remove the heat shield, screw the heating cones into their sockets, and replace the heat shield. When the Fan Box is plugged in to a suitable outlet, the fan will turn on and the controller display will light up showing the ambient temperature. The thermostat will control the temperature by turning the heat cones "on" and "off". When the cones are "on", a dot appears to the left of the temperature reading. The fan runs continuously while the power switch is "on" regardless of temperature setting. The Probe can be placed wherever the temperature is most critical.

UNHEATED FAN BOX:

The unheated Fan Box consists of a fan that circulates the Chamber's atmosphere through palladium Catalyst to remove oxygen and provide a homogeneous mixture of gases. When the unheated Fan Box is plugged into a suitable outlet, the fan will immediately turn on and run continuously; there is no "On/Off" switch. The unheated Fan Box is not equipped with heating devices, so it cannot control the Chambers temperature.

3. GAS LEAK DETECTOR

The Gas Leak Detector senses hydrocarbons and will detect pin hole leaks in the Anaerobic Chamber. To operate the Gas Leak Detector, twist the black knob to turn the unit on by turning the black knob to the maximum setting. After several minutes turn the knob down to the minimum setting and listen for a fast, high frequency beeping tone to slow down. This may take several minutes. The longer the sensor sets the longer the warm up period is required.

Rotating the black knob varies the speed of the tone. To detect leaks, turn the black knob so that the tone is at the slowest rate. Then turn the knob in the opposite direction so the beeping tone is on the verge of speeding up. Now you are ready to detect leaks. The Gas Leak Detector is energized by a single size "D" battery. Periodically you will have to replace the battery. To do this, remove the 4 screws securing the front panel. The "D" battery is accessible for replacement.

4. GAS PRESSURE REGULATOR

Gas Pressure Regulators decrease the pressure exiting from your gas supply (primary pressure) to a pressure suitable for the Airlock (secondary pressure). Pressure to the Airlock MUST NOT exceed 20 psi; 15 psi is recommended. The Gas Regulator supplied should be used with a gas mix tank of no more than 5% Hydrogen. The Gas Regulator attaches directly to the supply tank. The gas mix Regulator has a male Quick-Disconnect fitting. Flexible Tygon tubing connects the Regulators to the Glove Box and Airlock.

Once the Gas Regulators are installed, SLOWLY open the supply tank valves. The primary pressure gauge will now display the amount of gas remaining in the tank. Turn the pressure gauge valve to regulate the gas flow to the airlock (secondary pressure gauge) to read 15 psi.

5. STAK-PAKS (Catalyst and Desiccant)

Stak-Paks are constructed of a clear anodized aluminum frame and stainless steel screen. Their purpose is to provide users flexibility when adding chemicals to the Glove Box in order to produce a controlled environment.

No more than 3 Stak Paks should be stacked per fan box, and the Stak-Pak containing the catalyst should always be placed closest to the fan box to ensure strictest anaerobic environment. See figure #7 and #8 for details on multiple stak-paks.

NOTE: Both heated and unheated Fan Boxes can accept Stak-Paks.
Commonly used substances for the Stak-Paks

1. PALLADIUM CATALYST
2. DESICCANT
3. ACTIVATED CHARCOAL

Aluminum and stainless steel construction allows the user to elevate rejuvenation temperature and decrease time.

NOTE: See Section 4.3 (page 19) for details on controlling moisture with Desiccant Stak-Paks.

Figure #7 Multiple Stak-Pak Mounting

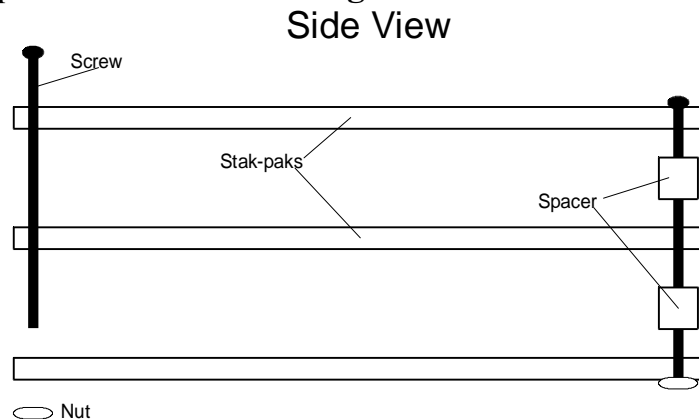

Figure #8 Top View of Stak-Pak



Desiccant Stak-Paks

The desiccant Stak-Paks are designed to maintain ambient humidity levels in the COY Anaerobic Chambers, however high volume and a busy chamber (lots of airlock activity) may introduce more oxygen than the standard one or 2 Desiccant Stak-Paks can handle so additional Desiccant Stak-Paks are required. The Desiccant will need to be rejuvenated on the same schedule as the Catalyst Stak-Paks. If condensation and water build up begin to form on the chamber walls, it is a sign the desiccant needs rejuvenation. The desiccant should be replaced once a year.

3.2 OPTIONAL EQUIPMENT

1. OXYGEN/HYDROGEN ANALYZER

Coy Labs Oxygen/Hydrogen Analyzer is designed to monitor the oxygen/hydrogen content inside an Anaerobic Chamber. It has two independent digital readouts that display oxygen in parts per million (ppm) and hydrogen in percent(%). To operate the Analyzer simply plug it into a suitable outlet (plug strip) and allow 1 hour for it to stabilize. It will then correctly display the oxygen and hydrogen content inside the Chamber.

The Analyzer has two separate alarms; one for the oxygen channel and one for the hydrogen channel. The oxygen alarm is user adjustable (preset at the factory to 300 ppm) by simultaneously depressing the "ALARM CONTROL" switch and rotating the "ALARM SET" pot with a small screwdriver. If the oxygen content inside the Chamber exceeds the preset value, an audible and visual alarm will indicate a high oxygen content.

The hydrogen alarm is not user adjustable, it is preset at the factory to 1% for low hydrogen condition and 10% for high hydrogen condition. As with the oxygen channel, the hydrogen channel also has an audible and visual alarm. If the hydrogen content goes below 1% or above 10%, the alarms will indicate a problem.

CAUTION. Gas mixes containing more than 5% hydrogen may be flammable.

2. INCANDESCENT FLAMING DEVICE (IFD)

To operate the IFD, plug the unit into the plug strip inside the chamber. Then run the foot switch through a feed through adapter (one will need to be provided at time of order) Every time the foot switch is depressed the IFD turns on, and in a few seconds the "Nichrome" wire loop will turn bright red. To flame a bacteria loop, simply insert the loop into the hot wire coil and withdraw it slowly. When the foot switch is released, the IFD will turn off. The IFD is designed to operate on an intermittent basis only, IT SHOULD NEVER BE LEFT UNATTENDED WHILE IN OPERATION. Periodically, you will have to replace the "Nichrome" wire loop. To do this, unscrew two terminals holding the old "Nichrome" wire loop. Then, insert the new "Nichrome" wire loop and tighten the terminals. You may have to spread the leads on the new loop to achieve a satisfactory fit.

3. RECIRCULATING ATMOSPHERE FILTER

The Atmosphere Filter consists of a filter housing, small vacuum pump and tubing. The atmosphere is circulated through the pump then through the filter and back into the chamber. This removes 99.9% of airborne contamination with a size of 0.3 micron or larger. The pump cycles 30 cu. ft. per hour. Depending on the contamination present you may have to run the filter 2-3 times a week or just a few times a month.

5. GAS INJECTION SYSTEM

Consisting of small, internal vacuum pump, solenoid valve and 3 timers, the Gas Injection System is designed to maintain a constant level of hydrogen gas mix in your anaerobic system. The timers allow the user to fully adjust how often the gas mix (H₂ 5%) is purged into the system and for how long. As each anaerobic chamber has different usage levels this item allows for those adjustments.

6. Arm Port Plugs

Place the Arm Port Plugs on to their appropriate holders on the interior of the glove box (See figure below).

NOTE: The Arm Port Plugs should not be placed in the Arm Ports during initial purge as the interior of the gloves need to be purged as well. During the purge the gloves will stick straight out this is normal.

Figure #1: Installation of Arm Port Plugs

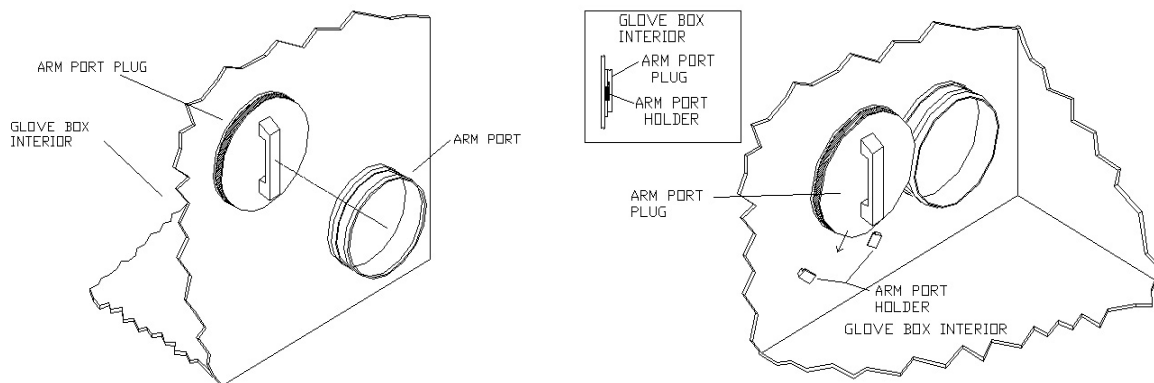

7. Automatic Purge Airlock Operation

Set Up

- Plug the unit into a 110 volt AC 60 Hz line or a 220 volt AC 50 Hz line, depending on the unit. A label on the back left hand corner of the airlock will display the power requirements.
- Connect the gas line onto the gas inlet fitting. If bringing the airlock **BELOW** ambient oxygen conditions, use chamber background gas as the inlet gas.
- If bringing the airlock **ABOVE** ambient oxygen conditions, use oxygen as the inlet gas. Maximum gas inlet pressure is 15 psi.
- Connect the gas outlet from Automatic Purge unit to the gas inlet on the Airlock using the following instructions.

If a *COY* Oxygen Controller is installed with the airlock, the gas line from the controller can also be common with the airlock. **NOTE: the maximum inlet pressure for the controller is 15 psi.**

1. The airlock must be set up as described in the Set Up instructions.
2. Turn the power on using the **On/Off** rocker switch on the front of the airlock.
3. Be sure the doors are closed.
4. **Set the timer for the desired purge time in seconds.**
 - a. Each of the numbers on the keypad represents a digit in the display the number one (1) keypad represents the 1st digit from the right, the 2 controls the second digit from the right and so on. The RST button is a reset button to stop a purge in progress.
 - b. To change each digit press and hold the button, the numbers will cycle 0-9. Release the button when the number you desire is reached. NOTE: the 4th digit does not display a 0 but is blank instead.
 - c. The timer will count down from the set time to zero, always displaying the time remaining on the purge.

Front Panel Diagram

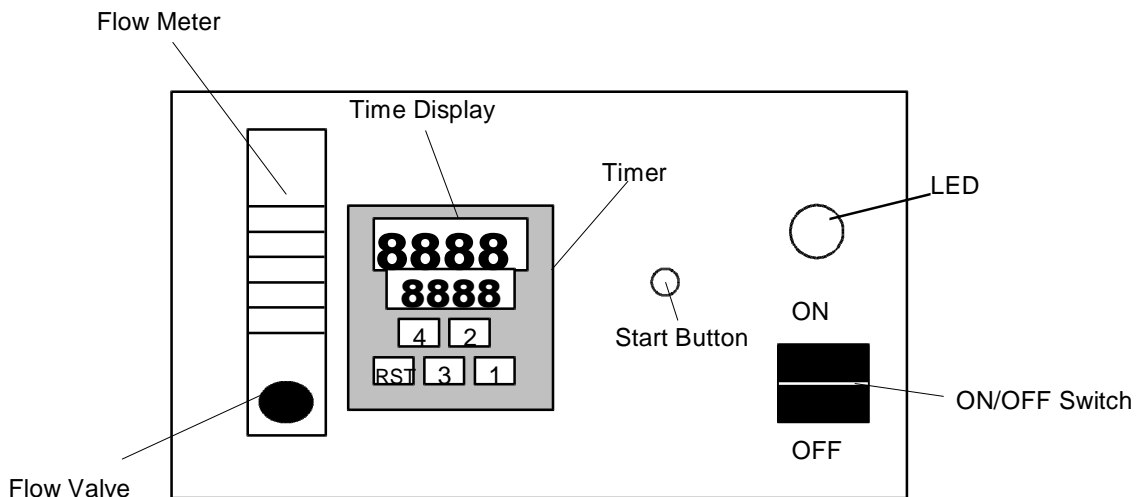

Button Controls

- RST = Reset
- 4 = Controls the 4th digit in the set point
- 3 = Controls the 3rd digit in the set point
- 2 = Controls the 2nd digit in the set point
- 1 = Controls the 1st digit in the set point

Rear Panel Diagram

Not seen on Gloveless Anaerobic Chambers or Heated Hypoxic Units.

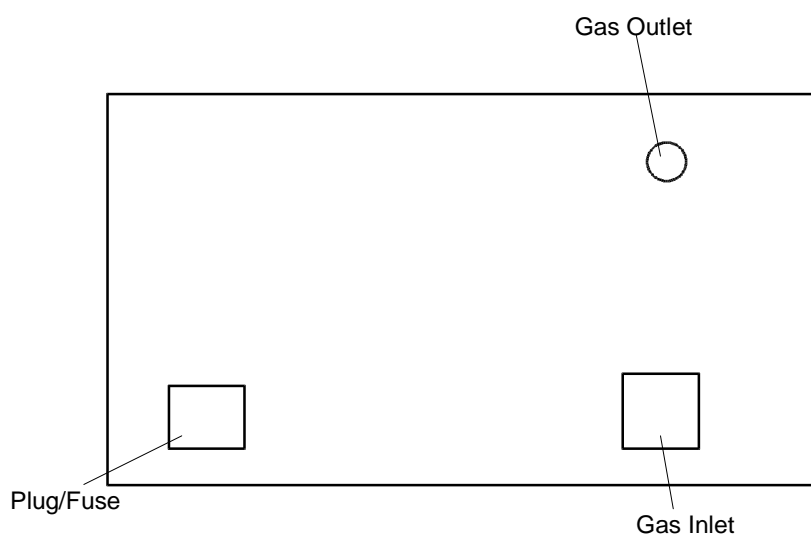

NOTE: Never purge the airlock at a higher rate than 15 psi. (with 1/4" OD Tubing) Doing so could over pressurize and damage the airlock and purge unit. Damage from over pressurizing the airlock will void the warranty.

Automatic Purge Airlock

Time	Purge Rate SCFH (standard cubic feet per hour)	Final O2 % in the Airlock	Estimated O2 Entering the Chamber in PPM (parts per million)
80 seconds	90	1.4%	985
100 seconds	90	0.9%	535
120 seconds	90	0.4%	290
160 seconds	90	0%	20
210 seconds	90	0%	0

4.0 THEORY OF DESIGN

4.1 PALLADIUM CATALYST/GAS REACTION

- 4.1.1 The following is an explanation of how the catalyst and gases react to remove oxygen so an anaerobic condition may be retained.
- 4.1.2 The catalyst is constructed of alumina and coated with a thin layer of palladium chloride. The main purpose of the catalyst is to provide a meeting ground for oxygen and hydrogen. Water is formed when oxygen and hydrogen meet in the presence of palladium chloride. The alumina in the catalyst absorbs the water which is driven off during catalyst rejuvenation.
- 4.1.3 During normal operation, oxygen continuously enters the Chamber by diffusion and other means. Without the presence of hydrogen, the catalyst will not remove oxygen. Hydrogen, unfortunately, cannot enter the chamber by itself; you must introduce it into the chamber.

Using the airlock daily allows hydrogen from the gas mix to enter the chamber when you open the inside door. The COY Gas Injection System is another convenient way to introduce H₂ to the glove box automatically. Contact COY or your local COY Representative regarding this option.

Depending on how often you use the Chamber, both methods help to ensure the chamber has hydrogen. However, hydrogen concentration in your chamber will be diluted depending upon the volume of your Chamber.

- 4.1.4 Heat is generated by the catalyst when an abundance of oxygen and hydrogen combine. This is apparent when the chamber is initially purged. If the correct guidelines are followed when you purge the chamber, the catalyst will only feel warm to the touch.

4.2 OXYGEN ENTERING THROUGH AIRLOCK

- 4.2.1 Regardless of how many times the airlock is cycled, there will always be a small amount of oxygen entering the chamber. Removing oxygen is the catalyst's job. This amount differs, depending on the volumetric size of your chamber.
- 4.2.2 When the airlock's inside door is opened, the gases from the airlock will start to mix with gases in the chamber. Coy has found that gases from the airlock flow out of the airlock and across the chamber floor. If oxygen is present in the gases, it will flow across the chamber floor until it reaches the catalyst, at which time it will be removed (providing you have fresh catalyst and hydrogen present). Because the oxygen

concentration is higher in the airlock than in the Chamber, an oxygen gradient is created. Oxygen levels are greatest at the airlock door and become progressively less as the distance from the door increases.

4.3 CONTROLLING MOISTURE

4.3.1 ENTERING MOISTURE

Moisture can enter the chamber in several ways:

1. GAS SUPPLY TANK (GAS MIX)
2. AMBIENT MOISTURE IN THE AIRLOCK
3. MOISTURE PRODUCING MATERIAL IN THE CHAMBER
4. MIGRATION THROUGH THE CHAMBER WALLS
5. HUMIDITY CAUSED BY BEING LOCATED IMMEDIATELY BELOW AN AIR CONDITIONING UNIT

4.3.2 CONTROLLING MOISTURE

Moisture may be controlled in the chamber using alumina desiccant. For the best control, provide as much desiccant surface area as possible to the chambers atmosphere. Placing desiccant horizontally on a catalyst box does not meet this requirement since airflow is restricted. The Stak-Pak may be placed on their edge, vertically in the catalyst box.

The Stak-Pak is designed to allow up to 6 units to be stacked in the vertical position (see Figure #9). Mounting the Stak-Pak vertically allows the catalyst box to expose the maximum amount of chamber atmosphere to the desiccant, while minimizing airflow restriction. The use of Stak-Paks can be extended to palladium catalyst or a combination of each (catalyst and desiccant). Coy has found that moisture can be controlled to less than 20% for 3 days in a type 6 ft. glove box, with 2 catalyst boxes, using 6 Stak-Paks (3 in each catalyst box) containing alumina desiccant. With 2 sets of Stak-paks, moisture can be continuously controlled. As the desiccant absorbs moisture, its pores become saturated with water vapor and must be rejuvenated. Alumina desiccant contained in Stak-Paks can be rejuvenated at 125-200 deg. Celsius for 2 hours.

Figure #9 4 or more Stak-Paks (3 desiccants) mounted on a Fan Box

3 or more Desiccant Stak-Paks Place Vertically

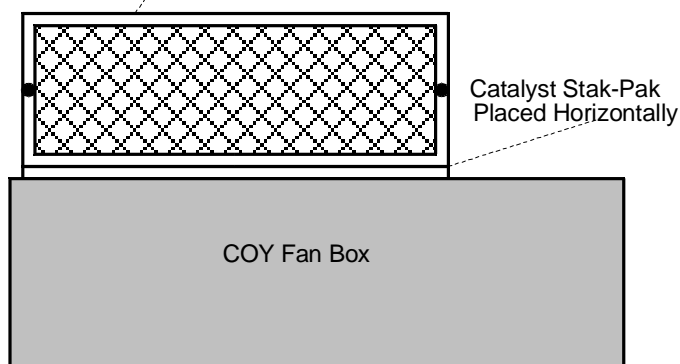

5.0 CARE AND MAINTENANCE

5.1 CARE OF POLYCARBONATE VIEWING SCREEN

5.1.1 PRECAUTIONS There are several precautions you can take to prolong the life of your chamber. Precautions you should carefully follow are:

1. DO NOT USE ABRASIVE CLEANERS AT ANY TIME.
2. DO NOT USE ANY SOLVENT LIKE LIQUIDS TO CLEAN THE PLASTIC. ISOPROPYL ALCOHOL IS ACCEPTABLE.
3. KEEP EQUIPMENT AND SHELVING UNITS WITHIN EASY REACH SO YOU DO NOT STRETCH THE CHAMBER SLEEVES.
4. RINGS AND JEWELRY SHOULD BE REMOVED PRIOR TO USING SO AS NOT SCRATCH THE POLYCARBONATE OR TEAR THE NEOPRENE SLEEVES.
5. PROTECT THE CHAMBER FROM ORGANIC SOLVENT FUMES AND NEARBY PAINTING AND PLASTERING. IF SPLASHED, WIPE IMMEDIATELY WHILE WET WITH A SOFT CLOTH.

5.1.2 CLEANING THE POLYCARBONATE

Dust and clean with a soft cloth or chamois having first sprayed on a plastic cleaner. (COY part no. 1600-480)

The use of a mild soap or detergent and plenty of water is good. Dry with a soft cloth or chamois.

Minor scratches can be removed by hand polishing. Polishes are best applied with a soft cloth dampened with water first. Several applications may be necessary, but most minor scratches can be reduced and the clarity improved in a short time.

Paper towels or any paper product (chem. Wipes) will scratch the surface after a period of time so these should not be used in cleaning the chamber.

5.2 CARE OF GLOVES

Gloveless Sleeve Replacement:

Use Figure #10 as a reference

To replace a sleeve, be sure the Arm Port Plugs are in place. Remove the stainless steel band, and blue rubber gasket holding the Sleeve to the Arm Port. Remove the Sleeve. Remove the latex Cuff and Mounting Ring from the Sleeve.

Attach the Mounting Ring and latex Cuff to the new Sleeve. Stretch the Sleeve over the arm port opening so that the rolled edge of the sleeve is between the groove and the chamber wall. Install the blue rubber gasket, and stainless steel band over the sleeve and in the groove. Be sure the blue rubber gasket is properly placed to protect the Sleeve from being cut by the stainless steel band. The new Sleeve is ready to use.

The arm length gloves are made of neoprene rubber and are susceptible to punctures and tears. Wear cotton gloves when working with sharp objects. Remove jewelry, and keep fingernails trimmed. If a hole is punctured in the sleeve, it must be replaced.

Replacement Gloves, Gloveless Sleeves and Replacement Cuffs may be purchased from COY Laboratory Products. Below is an illustration of how to install the replacement items.

Figure #10 Gloveless Sleeve Replacement

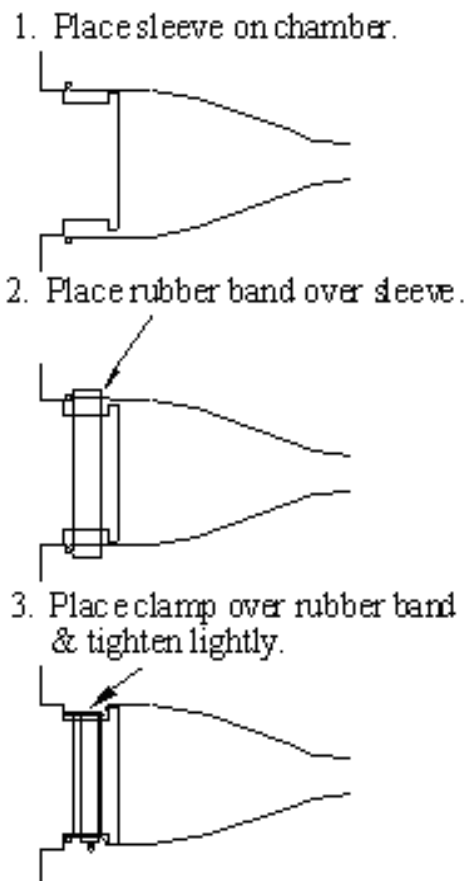

5.4 DETECTING LEAKS

Use the Gas Leak Detector to find pin hole leaks. Allow gas mix to enter the Chamber until there is a good positive pressure inside the chamber (gloves sticking straight out). Move the Detector around the glove box until the leak is found.

*NOTE: You will lose positive pressure relatively fast due to the pressure relief valves. To counter this plug the pressure relief valves and be extremely careful when adding the gas mix so that you do not **over pressurize** the chamber and damage it. Only inflate the glove box until the gloves are sticking straight out.*

6.0 ANSWERS TO QUESTIONS FREQUENTLY ASKED ABOUT THE CHAMBER

Q. 1. HOW MUCH GAS CAN I ANTICIPATE USING WHEN I OPERATE THE CHAMBER ON A ROUTINE BASIS?

A To purge the airlock for each use will require approximately 3 cu. ft. of gas mix. The initial set up of the Chamber will require approximately 50 cu. ft. Thereafter, use approximately 10 cu. ft. per week to maintain the proper environment.

Q. 2. HOW OFTEN, AT WHAT TEMPERATURE AND FOR HOW LONG DO I REJUVENATE MY CATALYST?

A. Rejuvenating the Catalyst is very important in keeping the Chamber in an anaerobic condition. Rejuvenating the Catalyst a minimum of once a week at 125-200° C for two hours is recommended. Included in the Chamber package are 2 sets of Catalyst Stak-Pak. Replace the Catalyst you rejuvenate with the extra set. Then your Chamber will always have fresh Catalyst. If you have an extremely busy glove box, you may need to rejuvenate the catalyst more frequently, even on a daily basis.

Q. 3. WHY DOES MY CHAMBER LOSE ITS ANAEROBIC CONDITION OVER A PERIOD OF TIME?

A. There are a couple of variables that must be considered to answer this question. First, does your Chamber have a leak? Second, is the catalyst fresh, has it been rejuvenated? Once these variables have been considered and eliminated from the probable cause, concentrate on the hydrogen content in the Chamber. Deficient hydrogen content is usually the cause for losing anaerobic conditions in the Chamber. Oxygen is constantly entering the Chamber by Airlock use and diffusion through the gloves. Without the hydrogen the catalyst cannot react to remove the oxygen.

You must keep in mind the dilution factor when the gas mix enters the Chamber. If you are using a 5% hydrogen gas mix your Chamber will not contain 5% hydrogen. It will be diluted to approximately 3.5% hydrogen. Coy Labs Oxygen/Hydrogen Analyzer can be used to display the amount of hydrogen in percent that is present in your Chamber. Also, the Analyzer has an alarm that indicates when the hydrogen content goes below 1%. If you have exhausted every probable cause and your Chamber still loses its anaerobic condition, test your gas mix for hydrogen content. We have seen and heard of gas companies that do not comply with customer specifications.

Q. 4. HOW DO I KNOW MY CATALYST IS WORKING AND HOW OFTEN SHOULD I REPLACE IT?

- A. A good test to determine if your catalyst is working is to place a tray containing catalyst inside the Airlock. Place a thermometer in direct contact with the catalyst. Then purge the Airlock (manual or automatic) with gas mix containing hydrogen. If the catalyst is working correctly, the temperature will increase due to the reaction of catalyst, oxygen, and hydrogen. Temperature will increase about 10 degrees Celsius over 10 to 15 minutes.

Coy recommends catalyst replacement on a yearly basis or if the catalyst does not respond to the above test.

Q. 5. WHERE DO MOST LEAKS OCCUR IN THE ANAEROBIC CHAMBER?

- A. Leaks can occur anywhere in the Chamber but most will be present around work areas. Before you begin leak detection, you must first make sure the Chamber contains your normal amount of pre-mixed gas. A towel saturated with isopropyl alcohol, and allowed to sit in the Chamber for a few minutes, will assist in detecting the very small (slow) leaks. With your gas leak detector, check the following areas first:

1. GLOVES
2. ALONG CHAMBER SLEEVES
3. AROUND AIRLOCK SEALS
4. AROUND LARGE DOOR SEALS
5. AROUND DIAPHRAGM TOP

Don't be alarmed if the beeping tone increase slightly around your neoprene rubber gloves. Neoprene rubber has a large pore structure and so will allow hydrogen to diffuse through. Around the gloves, lower the detector sensitivity since the diffusion will give the appearance of a leak.

Q. 6. WHAT WILL THE HYDROGEN SULFIDE PRODUCED BY SULFUR BACTERIA DO TO THE CHAMBER AND HOW CAN I CONTROL IT?

- A. It is important to control hydrogen sulfide in the Chamber because it attacks certain metals and can "poison" catalyst. Hydrogen sulfide is especially detrimental to the oxygen and hydrogen sensors in the Gas Analyzer, and to printed circuit boards in other equipment. COY printed circuit boards are coated with a protective substance, but hydrogen sulfide will attack any exposed metal and will, with time, creep under the coating, thus attacking the metal on the boards. The time taken to affect the metal will depend on the concentration of hydrogen sulfide and the humidity level.

To control hydrogen sulfide within the chamber, use one of the following methods:

1. ACTIVATED CHARCOAL
2. LEAD ACETATE
3. SILVER CHLORIDE
4. SILVER SULFATE

For chemicals 2 through 4 the sulfur will bind with the metal forming an insoluble precipitate leaving acetic acid (2 & 3) or sulfuric acid (4) as the byproduct. The activated charcoal will adsorb the hydrogen sulfide molecule. However, we generally DO NOT recommend its use since the adsorption is not specific to hydrogen sulfide, but is general to most molecules in the Chamber. A specific procedure for the use of silver sulfate is as follows:

1. Bring 2 liters of distilled water to a boil.
2. Add 10g of silver sulfate ($\text{Ag}_2\text{O}_4\text{S}$) to the boiling water and allow it to dissolve. This will take 5-10 minutes.
3. After the solution has cooled to near room temperature, add 20 ml of 1 N-aqueous sulfuric acid (H_2SO_4). This will inhibit the formation of carbonates in the solution.
4. Add 2 liters of Glycerol (Glycerin) and mix the solution thoroughly.

The glycerol will inhibit evaporation. The solution can be used in the Chamber by bubbling the atmosphere through it or by simply letting a beaker of it sit open in the Chamber. Add water to the vessel if necessary to maintain the initial volume.

The silver sulfide formed is a black precipitate that serves as an indicator that your solution is removing Hydrogen Sulfide from the atmosphere. Over time you will learn what your vessel looks like when all of the silver sulfate has been converted to the precipitate. If you need to test the activity of your solution, you may use sodium sulfide. When put into an active solution the black precipitate, silver sulfide, will form.

Q. 8. WHAT KIND OF DISINFECTANT CAN I USE IN MY CHAMBER?

- A. With proper care, Isopropyl Alcohol (I.P.A.) or a 1%-2% Clorox solution may be used. Make sure that the substance used is completely wiped off the Polycarbonate portions of the glove box because if allowed to sit on the Polycarbonate for extended periods of time it will degrade the surface.