

# CARBOLITE®

## Installation, Operation & Maintenance Instructions

1400°C - 1600°C Tube furnaces

STF Models

This manual is for the guidance of operators of the above products and should be read before the furnace is connected to the electricity supply.

---

### CONTENTS

Section		page
1.0	Introduction	2
2.0	Installation	3
3.0	Operation	6
4.0	Maintenance	8
5.0	Repairs & Replacements	10
6.0	Fault Analysis	13
7.0	Circuit Diagrams	14
0	Fuses & Power Settings	16
8.0	Specifications	17

---

**Manuals are supplied separately for the furnace controller (and overtemperature controller when fitted).**

Please read the controller manuals before operating the furnace.

**1.0 INTRODUCTION**

**1.1 Products Covered**

This manual contains installation and operating instructions for the single-zone STF 14, 15 & 16 model tube furnaces.

These furnaces may all be supplied either in horizontal or vertical format, to customer order. The horizontal ones are fixed to a base that houses the controls, while the vertical models are fitted to an “L-stand” and connected by flexible conduit to a separate control box. The L-stand is designed to allow the furnaces to be used horizontally as well as vertically.

This manual covers models currently in production, but may be used in retrospect for older versions, with the understanding that details of the circuit diagrams may differ, and that there may have been changes in heating elements and power considerations. If informed of the serial number, Carbolite can advise on older models.

**1.2 Switches and Lights**



Instrument switch: when the instrument switch is operated the temperature control circuit is energised.



Heat Switch: the switch disconnects power to the heating elements; unless this switch is off there is a danger of electric shock when inserting objects into the furnace



Heat Light: the adjacent light glows or flashes to indicate that power is being supplied to the elements

**1.3 Warning Symbols**

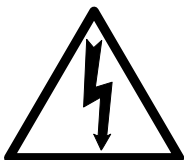

DANGER of electrical shock– read any warning printed by this symbol.



DANGER – hot surface. Read any warning printed by this symbol.  
WARNING: all surfaces of a furnace may be hot.



DANGER – read any warning printed by this symbol.

## 2.0 INSTALLATION

### 2.1 Unpacking & Handling

When unpacking or moving the furnace always lift it by its base. Never lift it by its work tube or the surrounding insulation. Use two people to carry the furnace; three where the control box is separate. Remove any packing material from inside the furnace before use.

NOTE: This product contains **Refractory Ceramic Fibre** (better described as **Alumino Silicate Wool**) for precautions and advice in handling this material see the 'Repairs and Replacements' section.

### 2.2 Siting

Place the furnace in a well ventilated room, away from other sources of heat, and on a surface which is resistant to accidental spillage of hot materials and which is not inflammable.

Ensure that there is free space around the furnace. Do not obstruct any of the vents in the control section: they are needed to keep the controls cool.

Ensure that the furnace is placed in such a way that it can be quickly switched off or disconnected from the electrical supply - see below.

### 2.3 Setting Up

If the furnace is supplied with a work tube then the holes at the end of the furnace chamber should be supplied at the correct size. Carefully line up the tube and ease it through the chamber.

For a tube of customer supply, ensure that there is approximately 1mm free play at each end; if the tube is too tight, it may crack when heated. Enlarge a tight hole by rotating the tube, which is abrasive. remove loose powdered ceramic fibre with a vacuum cleaner *and see section 5.1*. Contact Carbolite if the holes in the furnace chamber are too large.

Ensure that the tube is centrally placed and reaches to or through the furnace end covers, so that there is no access to exposed electrical connections.

*Vertical Mode.* The furnace (if a tube is also supplied) has a plate or clip to retain the tube in position. See fig.1.

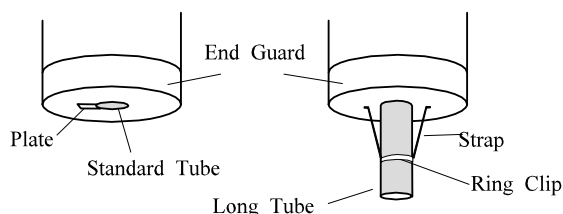

**Fig.1. - Vertical Tube Retention**

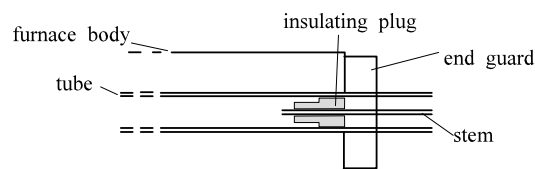

**Fig.2. - Insulating End Plug**

Fit any accessories supplied. For optimum temperature uniformity, insulating plugs or radiation shields should be placed in the tube ends as shown in fig.2. The ends of the shields should line up with the ends of the work tube.

**⚠ NOTE:** radiation shields are strongly recommended for all these furnaces. Contact Carbolite for further information.

If stainless steel seals with gas inlets are supplied they are to be fitted as shown in fig.3; the stem of any insulating plug should touch the seal.

When stainless steel seals are fitted in the vertical mode, a hook and eye holds the upper insulating plug assembly; alternatively a gland nut.

If heavy fittings are to be clamped to the end of an extended work tube they can increase the bending stress at the centre of the tube. Support such fittings in such a way that expansion of the tube is allowed.

If a metal work tube is being used in the furnace, ensure that it is earthed (grounded). There can be leakage of current through ceramic insulation at high temperatures.

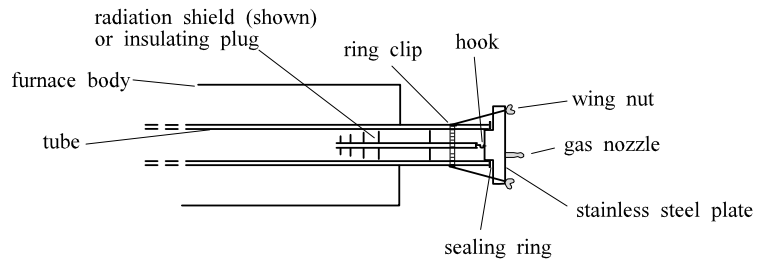

**Fig.3. - Stainless Steel End Seal**

**2.4 Heating Elements**

The Silicon Carbide elements are VERY FRAGILE and are packed separately. Fit them according to the instructions in section 5.6.

**2.5 Electrical Connections**

*Connection by a qualified electrician is recommended.*

The furnaces have one to three internal circuits, depending on model and voltage option. All may be ordered for single phase use; all may be ordered for two phases out of a three phase and neutral supply, and some for a three phase supply.

Check the furnace rating label before connection. The supply voltage should agree with the voltage on the label, and the supply capacity should be sufficient for the amperage on the label.

The supply should be fused at the next size equal to or higher than the amperage on the label. A table of the most common fuse ratings is also given in section 7.6 of this manual. Where a supply cable is present there are internal supply fuses; customer fusing is preferred but not essential.

Furnace with supply cable: either wire directly to an isolator or fitted with a line plug.

Furnace without supply cable: a permanent connection to a fused and isolated supply should be made to the internal terminals after temporary removal of the furnace back panel.

Connection by line plug: the plug should be within reach of the operator, and should be quickly removable.

Connection to isolating switch: this should operate on both conductors (single phase) or on all live conductors (three phase), and should be within reach of the operator.

The supply MUST incorporate an earth (ground).

CONNECTION DETAILS			<i>supply type</i>	
<b>Supply</b>	<b>Terminal label</b>	<b>Cable colour</b>	<i>Live-Neutral</i>	<i>Reversible or Live-Live</i>
<b><i>1-phase</i></b>	L	Brown	To live	to either power conductor
	N	Blue	To neutral	to the other power conductor
	PE	Green/Yellow	To earth (ground)	to earth (ground)
<b>supply</b>	<b>Terminal label</b>	<b>Cable colour</b>		
<b><i>2- or 3-phase</i></b>	L1	Black	to phase 1	
	L2	Black	to phase 2	
	L3	Black	to phase 3 <i>except 2-phase</i>	
	N	Light Blue	to neutral <i>except delta</i>	

---

	PE	Green/Yellow	to earth (ground)
--	----	--------------	-------------------

**Technical Notes**

The furnaces covered by this manual have electronically controlled power limits. Do not attempt to calculate the Amps from the Wattage. High break capacity fuses should be used. Avoid fast-blow fuses and magnetic trip circuit breakers - consult Carbolite if in doubt.

Two-phase models use two phases out of a 3-phase+neutral supply. One phase is unused. The neutral current is equal to the current in one of the used phases.

### 3.0 OPERATION

*The instructions for operating the temperature controller are given in a separate manual.*

*If the furnace is fitted with a time switch, see also the supplementary manual LS03.*

*If cascade control is fitted, see the supplementary manual LS07.*

#### 3.1 Operating Cycle

The furnace is fitted with an instrument switch. The switch cuts off power to the control circuit. There is also a heater switch which can be used to disconnect power to the elements.

Connect the furnace to the electrical supply.

Operate the instrument switch to activate the temperature controller. The controller becomes illuminated and goes through a short test cycle.

Adjust the temperature controller (see controller manual).

*Overtemperature option only.* If the overtemperature controller has not yet been set as required, set it and activate it according to the instructions in the appropriate manual.

Unless a time switch is fitted and is off, the furnace starts to heat up. The Heat light(s) glow steadily at first and then flash as the furnace approaches the desired temperature or a program setpoint.

*Overtemperature option only.* If the overtemperature trip operates then an indicator in the overtemperature controller flashes, and the heating elements are isolated. Find and correct the cause before resetting the overtemperature controller according to the instructions supplied.

To turn the furnace off, set the Instrument switch to its off position; the controller display will go blank. If the furnace is to be left off unattended, isolate it the electrical supply.

#### 3.2 General Operating Advice

Heating element life is shortened by use at temperatures close to maximum. Do not leave the furnace at high temperature when not required. The maximum temperature is shown on the furnace rating label and on the back page of this manual.

Light weight ceramic fibre insulation can easily be marked by accidental contact. Some fine cracks may be visible on the surface of the insulation, or may develop in the surface of the chamber due to the progressive shrinkage of the insulation materials. Cracks are not usually detrimental to the functioning or the safety of the furnace.

#### 3.3 Operator Safety



The ceramic materials used in furnace manufacture become electrically conductive to some extent at high temperatures. DO NOT use any conductive tools within the work tube without isolating it.

If a metal work tube is used, it must be earthed (grounded). Note that the furnace temperature should be limited if a metal tube is used.



Ensure that there are no inflammable objects placed in such a way that the work tube could break and fall on them.



Switch off the Heater switch whenever loading or unloading the furnace. The elements are isolated when the Heater switch is OFF. This switch cuts both sides of the circuit directly or via a contactor (a contactor is used in models where the rated current exceeds 16 Amps).

#### 3.4 Tube Life

A ceramic work tube may crack if workpieces are inserted too quickly or at temperatures below 900°C (when the tube is more brittle). Large pieces should also be heated

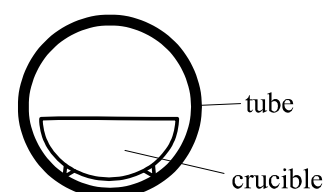

Fig 4MF08 - 1.13  
avoidance of thermal contact

slowly to ensure that large temperature differences do not arise.

Poor thermal contact should be encouraged between the workpiece and the tube; crucibles or boats should be of low thermal mass and should have feet to reduce the contact with the tube (fig. 4).

Do not set too high a heating rate. Large diameter tubes are more susceptible to thermal shock than smaller. A general rule for maximum heating rate is  $400/\text{internal diameter}$  ( $^{\circ}\text{C}/\text{min}$ ); for 75mm i/d tubes this comes to  $5^{\circ}\text{C}$  per minute. The controller can be set to limit the heating rate.

### **3.5 Pressure**

Work tubes are not able to accept high internal pressure. When gas seals or similar fittings are in use, the gas pressure should be restricted to a maximum of 0.2 bar (3 psi). A pressure of about half of that should normally be sufficient to achieve the desired flow rate. The customer must ensure that the exhaust path from the tube is not blocked, so that excess pressure does not occur.

## **4.0 MAINTENANCE**

### **4.1 Routine Maintenance**

Adjustment of the power setting may be required from time to time as described above. Otherwise no routine maintenance is required except for the replacement of consumable items as required.

The outer surfaces may be cleaned with a damp cloth. Do not allow water to enter the interior of the case, tube or control box. Do not clean with organic solvents.

### **4.2 Calibration**

After prolonged use the controller and/or thermocouple could require recalibration. This would be important for processes which require accurate temperature readings or which use the furnace close to its maximum temperature. A quick check using an independent thermocouple and temperature indicator should be made from time to time to determine whether full calibration is required. Carbolite can supply these items.

Depending on the controller, the controller manual may contain calibration instructions.

### **4.3 After Sales Service**

Carbolite's service division (Carbolite Engineering Services) has a team of Service Engineers capable of repair, calibration and preventive maintenance of furnace and oven products at our customers' premises throughout the world. We also sell spares by mail order. A telephone call or fax often enables a fault to be diagnosed and the necessary spare part despatched.

Each furnace has its own record card at Carbolite. In all correspondence please quote the serial number, model type and voltage given on the rating label of the furnace. The serial number and model type are also given on the front of this booklet when supplied with a furnace.

To contact Carbolite Engineering Services or Carbolite see the back page of this manual.

### **4.4 Recommended Spares Kits**

Carbolite can supply individual spares, or a kit of the items most likely to be required. Ordering a kit in advance can save time in the event of a breakdown.

When ordering spares please quote the model details as requested above.



#### 4.5 Power Adjustment

The furnace control system incorporates electronic power limiting. Power is supplied to the elements in bursts of about 1/3rd second duration. This prevents overheating of the elements. The power limit is programmed into the furnace controller and may be calculated as a percentage as follows:

$$\text{powerlimit} = (100 \times \text{targetpower} \times \text{ohms}) / \text{volts}^2$$

where targetpower is the wattage given on the furnace rating label  
 ohms is the overall resistance of the combined element circuits (see example)  
 volts is the voltage across each element circuit (e.g. 240 for a 415/240V supply)

example:

2-phase furnace with 3 elements of 2.9 ohms each in series per phase, running on 380/220V, with a target power of 7000W:

$$\text{ohms} = 2.9 \times 3/2 = 4.35$$

$$\text{powerlimit} = (100 \times 7000 \times 4.35) / (220 \times 220) = 63\%$$

A table of power limit settings is given in section 7.7. These are the settings for the furnace with new elements as supplied.

Occasionally the power limit is set to zero to permit demonstration of the controls without the heating elements taking power. In this case the power limit is accessible to the operator and may be reset to its standard value or the value that it had before setting to zero.

#### 4.6 Element Aging

Silicon carbide elements gradually increase in resistance with use: a process known as aging. Their heating power reduces correspondingly. To ensure sufficient power to the furnace it may be necessary to adjust the power limit, and, ultimately, to replace the elements - taking care to readjust the power limit.

If the furnace does not reach temperature, or is slow, measure the element resistances and calculate the required power limit using the method given above. If it exceeds 100%, the elements have too high a resistance and need replacing: check your data and calculations with Carbolite.

See the separate manual supplied for how to adjust the controller. Always record the setting when first making an adjustment. If new elements are fitted, return the adjustments to the original value, or remeasure and recalculate.

## 5.0 **REPAIRS & REPLACEMENTS**

### 5.1 **Safety Warning – Disconnection from Supply**

Always ensure that the furnace is disconnected from the supply before repair work is carried out.



### 5.2 **Safety Note - Refractory Fibrous Insulation**

**Insulation made from High Temperature Insulation Wool**

**Refractory Ceramic Fibre, (better described as Alumino Silicate Wool) (ASW)**



This product contains **alumino silicate wool products** in its thermal insulation. These materials may be in the form of blanket or felt, formed board or shapes, mineral wool slab or loose fill wool.

Whilst there is no evidence of any long term health hazards, we strongly recommend that safety precautions are taken whenever the materials are handled.

**Exposure to fibrous dust may cause respiratory disease.**

**When handling the material always use an approved respiratory protection equipment (RPE-i.e. FFP3), eye protection, gloves and long sleeved clothing.**

**Avoid breaking up waste material. Dispose of waste in sealed containers.**

**After handling rinse exposed skin with water before washing gently with soap (not detergent). Wash work clothing separately.**

Before commencing any major repairs we recommend reference to the European Association representing the High Temperature Insulation Wool industry ([www.ecfia.eu](http://www.ecfia.eu))

We can provide further information on request. Alternatively our service division can quote for any repairs to be carried out at your premises or ours.

### 5.3 **Temperature Controller Replacement**

2216, 2416, 2408 etc. Ease apart the two lugs at the side; grip the instrument and withdraw it from its sleeve; push in the replacement.

### 5.4 **Solid-state Relay Replacement**

Disconnect the furnace from the supply and remove the back panel from the base or control box..

Make a note of how the wires are connected to the solid state relay, and disconnect them. Remove the solid state relay from the base panel or aluminium plate.

Replace and reconnect the solid state relay ensuring that the heat-conducting thermal pad is sandwiched between the relay and the base panel or aluminium plate. Alternatively a thin layer of white, heat-conducting silicon paste may be applied between the new relay and the plate.

The new solid state relay contains a built-in MOV which protects it from short periods of excess voltage. If the old relay had a separate disc-shaped "MOV" connected between the high voltage terminals of the old relay, discard the old MOV.

Replace the removed panel.

## 5.5 Thermocouple Replacement

The coverings and guards which must be removed to gain access to the thermocouple depend on the model, its orientation (horizontal or vertical), and possibly other options and fittings. It is usually necessary to separate a horizontal furnace from its base, or a vertical from its stand and/or terminal cover.

Disconnect the furnace from the supply, and separate the furnace body and/or remove covers and guards as necessary.

Make a note of the thermocouple connections. The negative leg of the thermocouple is marked blue. Compensating cable colour codings are:

<i>negative</i>	<i>positive (type r)</i>
white	orange

Disconnect the thermocouple from its terminal block.

Withdraw the thermocouple from its sheath and remove any broken bits of thermocouple. Alternatively, withdraw the sheath together with the thermocouple, first disconnecting any screws which hold the sheath in place.

Insert the new thermocouple (or thermocouple and sheath) into position, restoring any removed porcelain spacers, and ensuring correct polarity.

Re-assemble the furnace.

## 5.6 Element Fitting and Replacement

*Replacements: read the section on element aging (4.6). If at any time the power limit has been increased, reset it to its original value (section 7.7), or measure the resistances and recalculate the limit.*

Disconnect the furnace from the electrical supply.

Remove the furnace end guards to gain access to the element connections.

Remember that the elements are fragile and expensive, and that they can be damaged by contamination: handle them with care and keep them clean.

*Replacements: make a note of the actual braid and cable connections to the elements. From rod elements disconnect the clips with the special tool provided (or with finger pressure, depending on the type of clip fitted), lift off the braids and carefully withdraw each element. See fig.5.*

Carefully insert the new elements into the furnace. Ensure that the rod elements are placed centrally: the same length should be outside the insulation at each end.

*STF: Attach the braids according to the notes made, or according to the appropriate diagram, fig.6 to fig.8. Use the special tools (or finger pressure) to fit the clips. Take care that clips do not touch each other or any other metal parts.*

Replace the furnace end guards and connect the furnace to the supply.

If aged elements have been replaced, reset the furnace power limit.

If you have any problems with this procedure, please contact our service division.

Element Fitting - Figures

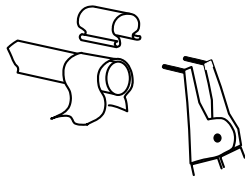

Fig.5. - Use of Clip Tool

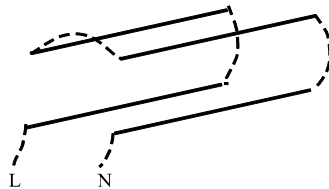

Fig.6. - Element Connections - 4 elements

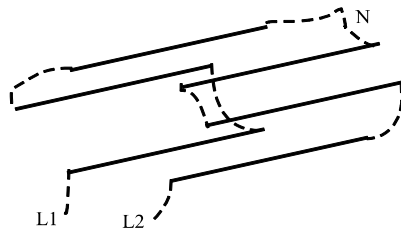

Fig.7. - Element Connections - 6 elements, 2 circuits

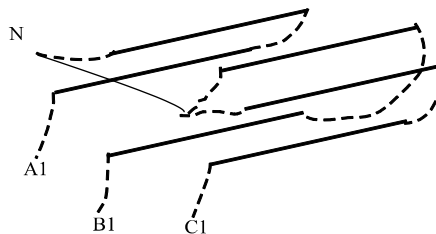

Fig.8. - Element Connections - 6 elements, 3 phase

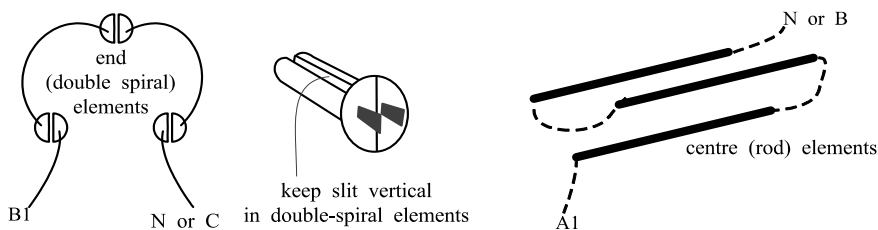

Fig.9. - Element Connections - 3-zone models

5.7 Fuse Replacement

Fuses are marked on the circuit diagram (section 7.0) with type codes, e.g. F1, F2. A list of the correct fuses is given in section 7.6. Depending on model and voltage, the different fuse types may or may not be fitted.

If any fuse has failed, it is advisable for an electrician to check the internal circuits. Replace any failed fuses with the correct type. For safety reasons do not fit larger capacity fuses without first consulting Carbolite.

The fuses are near the cable entry point, and access is by removal of the back panel.

## 6.0 FAULT ANALYSIS

### A. Furnace Does Not Heat Up

- |  |  |  |
|--|--|--|
| 1. The <b>HEAT</b> light is <b>ON</b>  | → The heating element has failed   | → Check also that the SSR is working correctly   |
| 2. The <b>HEAT</b> light is <b>OFF</b> | → The controller shows a <b>very high temperature</b> or a code such as S.br | → The thermocouple has broken or has a wiring fault  |
|  | → The controller shows a <b>low temperature</b>                              | → The heater switch may be faulty or be Off  |
|  |  | → The contactor (if fitted) may be faulty  |
|  |  | → The SSR could be failing to switch on due to internal failure, faulty logic wiring from the controller, or faulty controller |
|  | → There are no lights glowing on the controller                              | → Check the supply fuses and any fuses in the furnace control compartment  |
|  |  | → The controller may be faulty or not receiving a supply due to a faulty switch or a wiring fault                              |

### B. Furnace Overheats

- |  |   |  |
|--|---|--|
| 1. The <b>HEAT</b> light goes <b>OFF</b> with the instrument switch        | → The controller shows a <b>very high</b> temperature | → The controller is faulty   |
|  | → The controller shows a <b>low</b> temperature       | → The thermocouple may have been shorted out or may have been moved out of the heating chamber |
|  |   | → The thermocouple may be mounted the wrong way round  |
|  |   | → The controller may be faulty   |
| 2. The <b>HEAT</b> light <b>does not go off</b> with the instrument switch | → The SSR has failed "ON"                             | → Check for an accidental wiring fault which could have overloaded the SSR                     |

## 7.0 CIRCUIT DIAGRAMS

EMC Filters (if fitted): dependent on the model there may be one filter, or more than one fitted in parallel. The circuit diagram examples do not show multiple filter arrangements.

### 7.1 Single Phase

Applies for live-to-live supplies as well as live-to-neutral

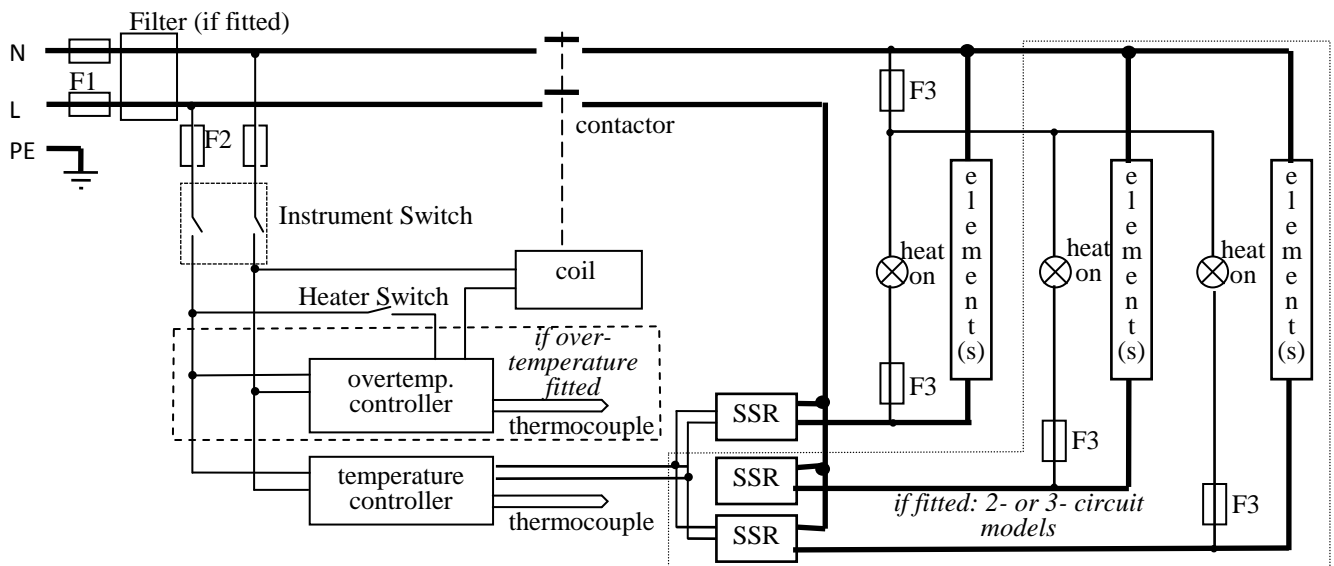

### 7.2 2-phase with neutral

As the following 3-phase diagram, except that one phase is not present.

Note that if the phase current is less than 25A/phase, a direct safety switches may be fitted in the element circuit, rather than the switch shown in the coil circuit.

### 7.3 3-phase with neutral

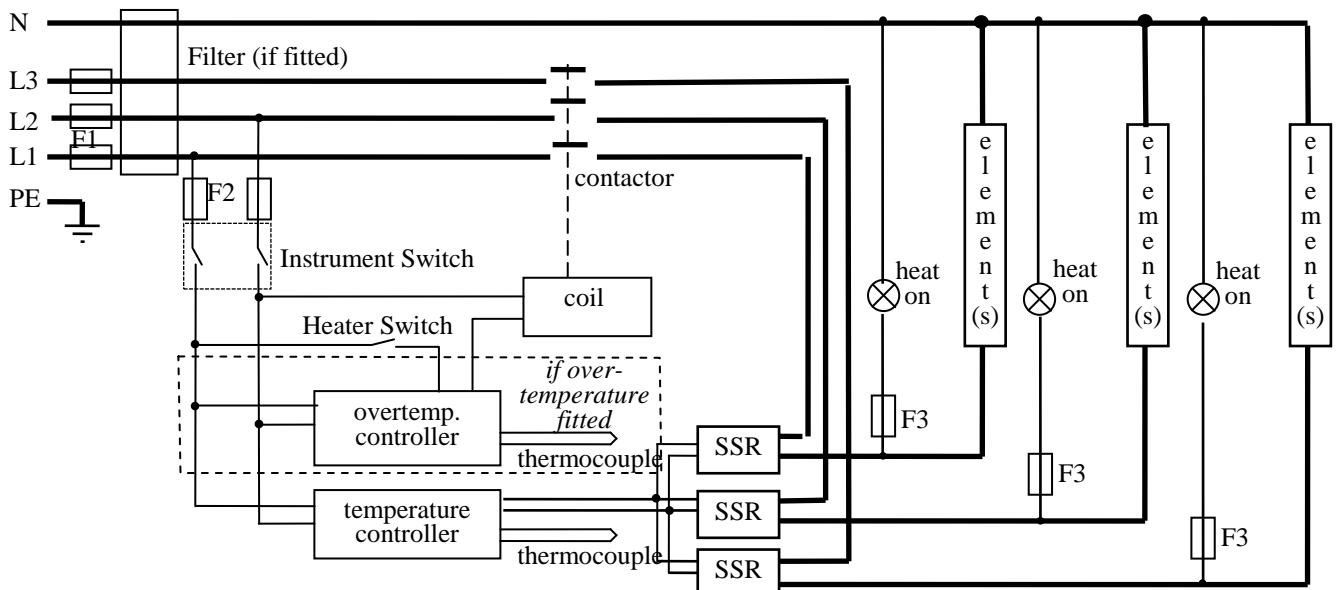

note on (2- and) 3-phase: depending on filter(s) fitted, there may be (2 or) 3 separate neutral wires from the elements to the neutral supply.

**3-phase without neutral (delta – 208 to 240V)**

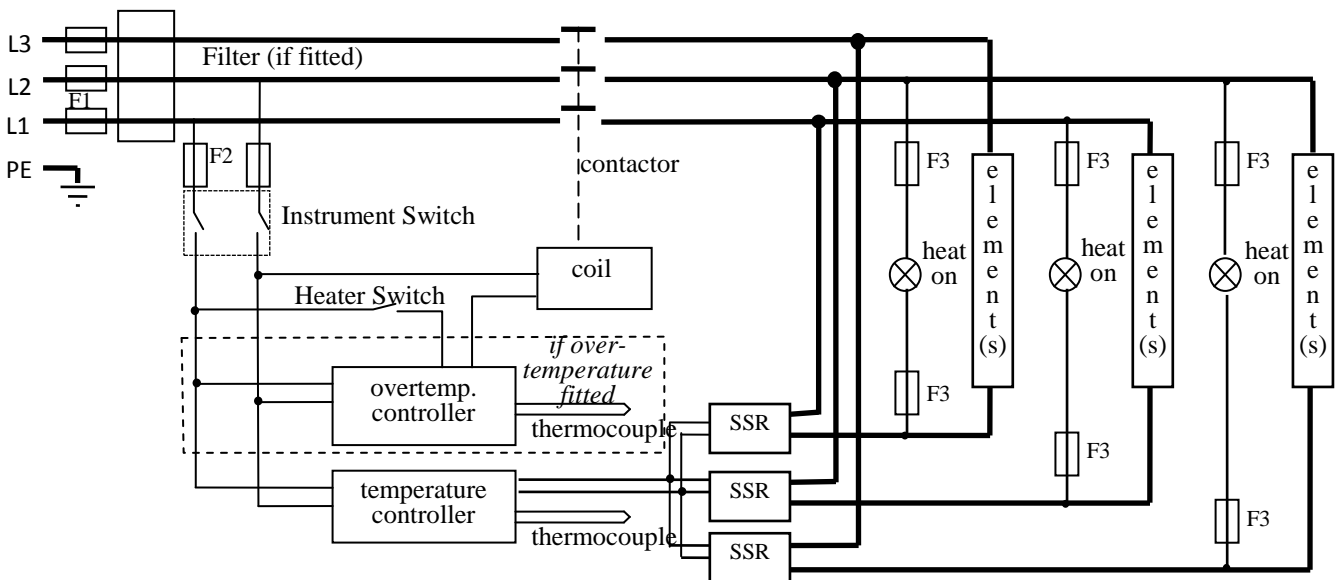

**7.4 3-phase without neutral (star – e.g. 380 to 415V)**

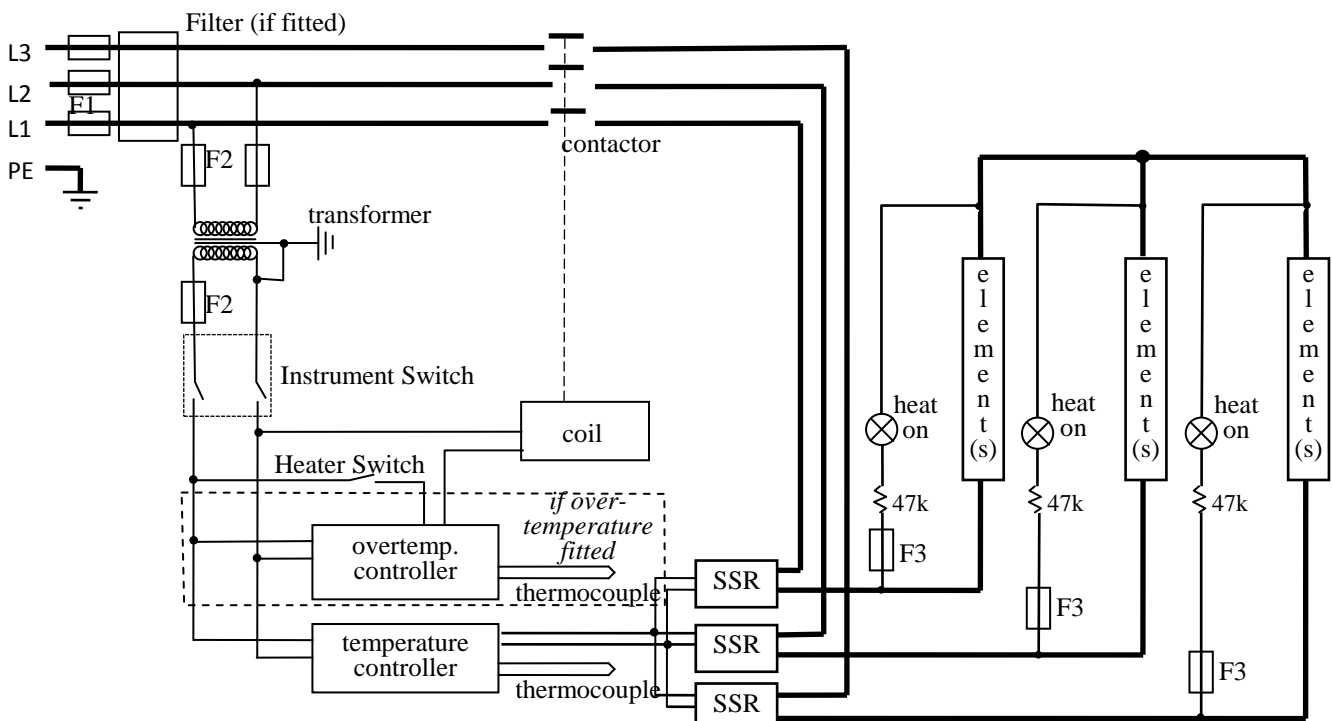

Note: in this configuration the fuses F2 on the supply side of the transformer may be GEC Safeclip, not 32 x 6mm glass as stated in section 7.7.

**7.5 Higher Voltages (e.g. 440V, 480V 3-phase)**

The diagram above (7.4) normally applies, with neutral (if present) not being used.

For single phase models of 254V or above, diagram 7.1 applies except that a control circuit transformer is included as in diagram 0.

**FUSES & POWER SETTINGS**

**7.6 Fuses** *F1-F3: Refer to the circuit diagrams.*

<i>F1</i>	Internal supply fuses	Fitted if supply cable fitted. Fitted on board to some types of EMC filter.	on-board and up to 16 Amps: 32mm x 6mm type F other: GEC Safeclip
<i>F2</i>	Auxiliary circuit fuses	Fitted on board to some types of EMC filter. May be omitted up to 25Amp/phase supply rating.	2 Amps glass type F On board: 20mm x 5mm Other: 32mm x 6mm
<i>F3</i>	Heat Light fuses	May be omitted up to 25 Amp/phase supply rating.	2 Amps glass type F 32mm x 6mm
	<b>Customer fuses</b>	Required if no supply cable fitted. Recommended if cable fitted.	See rating label for amperage; see table below for fuse rating.

Table of Supply Fuse Ratings:

Model	Volts:	Single phase			2-phase+N			3-phase delta		
		220V	230V	240V	380V	400V	415V	220V	230V	240V
STF 14/--/180		12.5A	12.5A	12.5A	-	-	-	-	-	-
STF 14/--/450		32A	32A	32A	20A	20A	20A	-	-	-
STF 14/--/610		40A	40A	40A	20A	20A	20A	-	-	-
STF 15/--/180		12.5A	12.5A	12.5A	-	-	-	-	-	-
STF 15/--/450		40A	40A	40A	20A	20A	20A	-	-	-
<i>STF 15/--/450 4-els *</i>		32A	32A	32A	-	-				
STF 15/--/610		40A	40A	40A	20A	20A	20A	-	-	-
STF 16/--/180		25A	25A	25A	-	-	-	-	-	-
STF 16/--/450		50A	50A	50A	25A	25A	25A	40A	40A	40A
STF 16/--/610		50A	50A	50A	25A	25A	25A	50A	50A	50A

*\* single phase model before December 2000 made with 4 elements*



## 7.7 Power Settings

The power limit settings (parameter  $\Delta PH_i$ ) for the STF models on various supply voltages are as follows. The figures represent the maximum percentage of time that controlled power is supplied to the elements. Do not attempt to “improve performance” by setting a value higher than the correct one from the table.

Model	Volts:	Single phase			2-phase+N			3-phase delta		
		220V	230V	240V	380V	400V	415V	220V	230V	240V
STF 14/--/180	-		45	41	-	-	-	-	-	-
STF 14/--/450	74	68	62	53	48	44	-	-	-	
STF 14/--/610	71	65	60	71	65	60	-	-	-	
STF 15/--/180	49	45	41	-	-	-	-	-	-	
STF 15/--/450	64	59	54	64	59	54	-	-	-	
STF 15/--/450 *	82	75	69	59	54	49				
STF 15/--/610	78	71	65	78	71	65	-	-	-	
STF 16/--/180	38	35	32	-	-	-	-	-	-	
STF 16/--/450	51	47	43	51	47	43	30	28	25	
STF 16/--/610	63	57	53	63	57	53	28	29	27	

\* 5000W model up to late 2000.

## 8.0 SPECIFICATIONS

Carbolite reserves the right to change specifications without notice.

### 8.1 Models Covered by this Manual

MODEL	Max. Temp. (°C)	Max. Power (kW)	Work Tube Bore <sup>1</sup> (mm)	Work Tube Length (mm)	Heated Length (mm)	Net Weight <sup>2</sup> (kg)
<i>Tube furnaces heated by Silicon Carbide elements</i>						
STF 14/--/180	1400°C	1.1	25-50	600-900	180	22
STF 14/--/450	1400°C	4.5	25-75	900-1200	450	35
STF 14/--/610	1400°C	5.5	25-75	1200-1500	610	40
STF 15/--/180	1500°C	1.5	25-50	600-900	180	22
STF 15/--/450	1500°C	5.5	25-75	900-1200	450	35
STF 15/--/610	1500°C	6.0	25-75	1200-1500	610	40
STF 16/--/180	1600°C	2.5	25-75	600-900	180	22
STF 16/--/450	1600°C	6.0	25-75	900-1200	450	35
STF 16/--/610	1600°C	7.0	25-75	1200-1500	610	40

note 1: Standard tube internal diameters of 25, 50 and 75 are available; intermediate tube sizes can also be fitted.

note 2: Weights are approximate for horizontal models and do not include fittings or vertical stands.

## 8.2 Environment

The furnaces contain electrical parts and should be stored and used in indoor conditions as follows:

temperature: 5°C - 40°C

relative humidity: maximum 80% up to 31°C decreasing linearly to 50% at 40°C



The products covered in this manual are only a small part of the wide range of ovens, chamber furnaces and tube furnaces manufactured by Carbolite for laboratory and industrial use. For further details of our standard or custom built products please contact us at the address below, or ask your nearest stockist.

---

*For preventive maintenance, repair and calibration of all Furnace and Oven products, please contact:*

**Carbolite Engineering Services**

**Telephone:** +44 (0)1433 624242

**Fax:** +44 (0)1433 624243

**Email:** [service@carbolite.com](mailto:service@carbolite.com)

**CARBOLITE**<sup>®</sup>  
ENGINEERING SERVICES

---

**CARBOLITE**<sup>®</sup>

Carbolite, Parsons Lane, Hope,  
Hope Valley, S33 6RB, England.  
**Telephone:** +44 (0)1433 620011  
**Fax:** +44 (0)1433 621198  
**E-mail:** [info@carbolite.com](mailto:info@carbolite.com)