



Rotavapor® R-300 System

Smart Evaporation



Rotavapor® R-300 System

Daily lab routines executed with minimal effort

A rotary evaporator should enable quick and efficient distillations with minimal amount of manual operation. Thanks to state-of-the-art components, such as heating bath, vacuum source, cooling and rotating devices, as well as centralized system control by a powerful interface, the Rotavapor® R-300 System offers an unprecedented amount of automation, flexibility and convenience for your distillation process.



High flexibility

The modular design of the Rotavapor® helps meet individual requirements. Thanks to a wide range of system accessories, more choice in use of lab space and the option to monitor the process remotely via a mobile device, users gain the ability to customize the distillation process to fit their unique needs.



Maximum convenience

The Rotavapor® can be easily operated with features such as one touch interface commands, fast flask handling with Combi-Clip, options to manually adjust system parameters with intuitively placed buttons.



Smart distillations

The “Smart distillations” of the Rotavapor® R-300 enable an automated, unattended process with optimized system parameters to take place. Users can flexibly program their own SOPs into the system and then monitor their distillations remotely via an app.



High flexibility

Tailored to individual needs

The modular design of the Rotavapor® and its flawless integration with state-of-the-art accessories help customize any distillation process



Modular design that fits individual requirements

Separate system components or accessories can be easily added, exchanged or upgraded on the R-300. The modularity of the system allows users to create a personalized platform that perfectly fits individual applications and budgets.



A wide range of accessories for a wide range of applications

Users can flexibly select from a large variety of system accessories that make any application possible. R-300 offers unparalleled choice in terms of heating bath temperature ranges, condenser types, flask sizes and more.



Flexible Interface positioning

The interface of the R-300 can be attached on a pump, on the Rotavapor® or on a wall, enabling work to be carried out inside or outside of a fume hood and to perfectly fit individual lab environments.

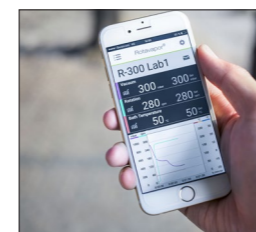

Save time with mobile process monitoring

The BUCHI Monitor App for mobile devices offers live views and graphical displays of process parameters, as well as push notifications when an action is required, to drastically reduce the hands-on time at the instrument and free valuable time for other tasks.



Maximum convenience User-friendly system design

From automatic control to simplified handling of system features, the Rotavapor® makes user comfort a top priority.



Intuitive system operation with one touch commands

The system interface enables effortless control of all process parameters even by untrained users. For ultimate time-savings, distillations can be performed with just a single click on a button.



Easy handling of flasks with Combi-Clip

With the unique Combi-Clip flask snap lock of the R-300, users need just one hand and a few seconds to attach and detach flasks, adding more speed and simplicity to the distillation process.



Fast reaction times thanks to real-time system control

In addition to automated operation, users can choose to manually adjust rotation speed and heating bath temperatures with easily reachable control buttons. Direct access enables users to act quickly in emergency situations.



Smart distillations

Facilitate daily routines

A high degree of automation enables unattended operation of the Rotavapor® for maximal time saving benefits.



Optimized productivity, streamlined processes and increased security with BUCHI Cloud Services

The cutting-edge BUCHI Cloud Services enable monitoring of all instruments on a mobile device, provide free updates by the push of a button.



Unattended operation

System elements such as foam sensor, dynamic distillation and solvent libraries allow for unattended Rotavapor® operation, freeing time for other work. Live parameter views and push notifications delivered to a mobile device enable off-site process monitoring.

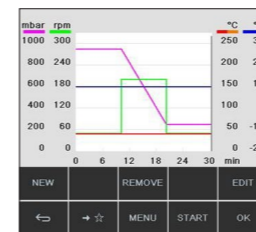

Automated execution of customized methods

With I-300 Pro, users can program the parameters of their own SOPs into the system and then preview the methods as graphs to reduce the risk of error. Push notifications alert the operator when the SOP is finished or manual interaction is required.

Rotavapor® more than just evaporation!

Explore the multiple applications use of the R-300

Thanks to a flexible system configuration, the Rotavapor® can be confidently used for even more applications than just distillations. In combination with suitable accessories, the system can be individually adapted to expertly fit various needs and achieve ambitious goals.

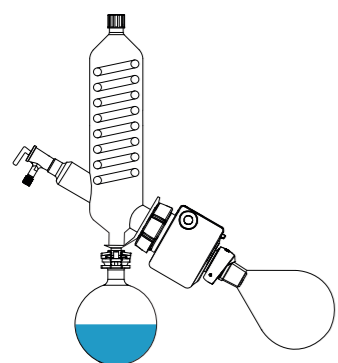

Evaporation

Fast distillation of mixed solvents

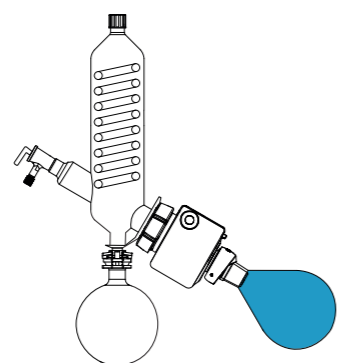

Drying

Efficient drying of samples

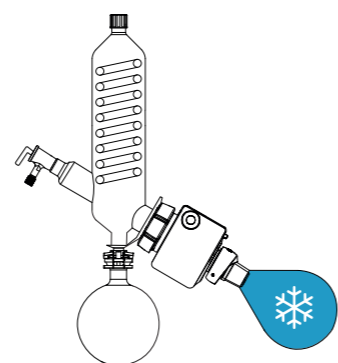

Freeze drying sample preparation

Quicker freeze-drying sample preparation

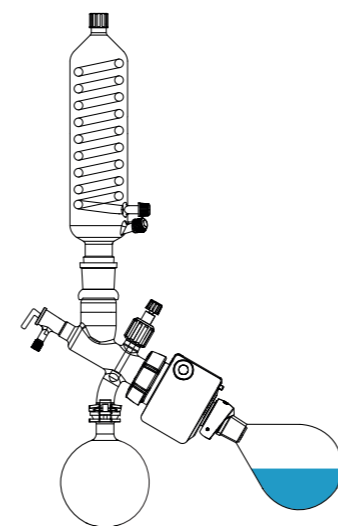

Reflux

Chemical synthesis under reflux

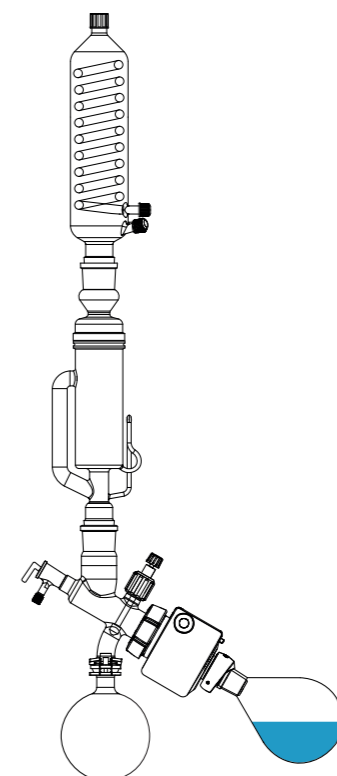

Extraction

Essential oils extraction from natural samples

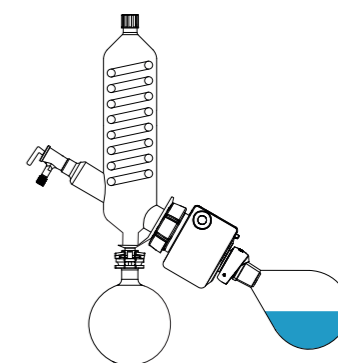

Concentration

Concentration of solutions to a specific level

Established operating modes

Use of solvent libraries for computerized parameter set-up that eliminates time-consuming manual steps

Unique automatic distillation capabilities

Digital detection of unknown solvent vapors and unattended operation

Hands-free foam detection

Automatic breaking of foam for unattended operation and lower contamination risk

Specialized drying flasks with indents

Substantial increase in the efficiency of the drying process

Dedicated drying mode option

A left-right rotation interval that prevents samples from sticking to the flask wall and optimizes performance and yield

Innovative design of beaker flasks

Easy cleaning and product removal due to large beaker opening

Exclusive Dewar accessories and glassware

Better heat transfer and a faster freeze-drying cycle

Efficient reflux condenser

Improved efficiency by better mixing capabilities and the flexibility to empty the receiving flask during the process

Specialized methods mode

Ability to program customized SOPs and perform reflux reactions

Effective use of Soxhlet accessory

Effortless combination of the reflux condenser with a Soxhlet device specialized for extraction of essential oils

Convenient level sensor

Precise volume control and flexible mounting of sensor on a secondary or main condenser

User-friendly timer mode

More simplicity and automation from sound alerts that indicate the process is finished

Easy integration of individual SOPs

Achieving optimal concentrations from programming own method into system interface



One system, one touch, endless possibilities

Central control of the whole system

Rotary evaporation requires a heating source, a rotation drive, a cooling device and a regulated vacuum. Only if all these elements interact seamlessly and are perfectly tuned, is distillation most effective. BUCHI provides an entire system with central interface which controls it all, just by the push of one button.



Rotavapor® R-300 - Highest degree of flexibility and convenience

The R-300 is a modular system that offers a more flexible distillation performance. An unrivaled number of instrument parts, including condensers, heating baths and glassware, help create a system tailored to individual needs. To find out more, refer to page 14.



Interface I-300 / I-300 Pro - Smart system control for more precision in less time

All parameters of the Rotavapor® System can be automatically controlled using the interface to improve precision and enable unattended system operation. Off-site monitoring optimizes the time-efficiency of the process. To learn more, see page 16.



Vacuum Pump V-300 / V-600 - Reliable pressure control for consistent distillations

The eco-friendly vacuum pump regulates pressure via speed control for more consistent distillations. The silent pump comes in two sizes and enables distillations of high and low boiling solvents for a more flexible process. Read more on page 18.



Recirculating Chiller F-305 / F-308 / F-314 - High cooling efficiency with low environmental costs

The chiller reduces water and energy waste, while still offering precise temperature control. Together with the interface, the chiller enables dynamic distillations with immediate process start for substantial time savings. For more details, see page 20.

Rotavapor® R-300

The most versatile of its kind

Rotavapor® is the leading rotary evaporation solution whose modularity helps to conveniently achieve challenging individual goals.



A multitude of condenser types

A choice of eight condenser types guarantees any requirement can be satisfied, ranging from unattended distillations, drying, concentrations and re-crystallizations, reflux reactions, distillations of foaming samples, work performed in fume hoods or tight spaces, evaporation of solvents with high temperature differences, high throughput reactions, condensations with dried ice as a coolant liquid and many others.



Vast assortment of vapor ducts

Vapor ducts are the glass parts that connect the evaporating flask to the Rotavapor®. All vapor ducts include the proprietary Combi-Clip for one-hand flask handling. Specialized ducts facilitate various processes ranging from powder drying to high temperature applications.



Impressive variety of glassware

BUCHI's unparalleled collection of glassware includes evaporating flasks ranging from 50 mL to 5 L in size, specialized flasks for drying applications, wide-necked beaker flasks for easy cleaning and product collection, distillation spiders for parallel evaporation and even more glassware types that make any application possible.



Customized lift handling

Configure your R-300 with a manual or an electronic lift according to your personal preference.



Flexible choice in baths

Highly efficient baths are available in 1 L or 5 L size with temperature ranges from -200 to 220 °C and with water or oil as a heating medium. This flexibility enables reliable distillations of low or high boiling solvents and quick freeze drying sample preparations.



Warned on time in case of unusual events

Both I-300 and I-300 Pro offer an integrated leak test to check the tightness of the system and alert the user if maintenance is needed. Early detection of malfunctions saves resources, time and protects the sample.

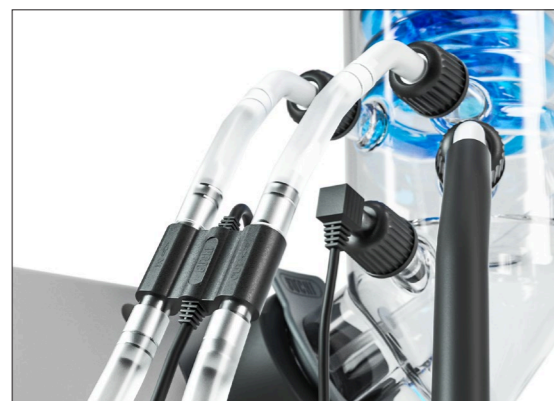

Leave the distillation process unattended

Thanks to state-of-the-art sensors, you can reduce instrument hands-on time to mere seconds. Automatic process optimization helps reduce solvent emissions into the lab environment to protect the operator.

Interface I-300 / I-300 Pro

Why should I choose one of these Interfaces?

From unattended operation with minimal risk of error to higher flexibility in the distillation process, there are plenty of reasons why you should equip your Rotavapor® with an I-300 or I-300 Pro Interface.



Gain access to numerous operating modes

I-300 and I-300 Pro offer several different operating modes suited to a wide range of requirements ranging from sample drying to manual or unattended operation.



Detect foamy samples

Both I-300 and I-300 Pro together with a cutting-edge foam sensor can automatically detect and eliminate foam production. Prevention of over-foaming makes unattended distillation possible, saving time and increasing reproducibility.

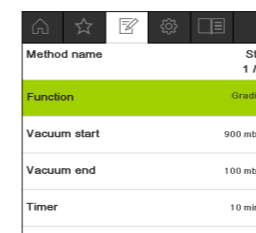

Set-up your own SOP parameters

With I-300 Pro, users can program their own method with all relevant parameters and then monitor the performance with live data charting for the most personalized and error-free experience possible.



Conveniently collect and transfer data

I-300 Pro can store all method parameters for full process traceability and simplified downstream data analysis.



Benefit from more precise vacuum regulation

Both I-300 and I-300 Pro offer close monitoring and automatic control of the vacuum pump to avoid problems such as re-boiling, bumping, condenser overloading, and failed distillation starts. The overall system performance is made quieter and more eco-friendly.



Directly see the condensation status

Condensed solvents or particles are easily visible thanks to a transparent inspection window, facilitating maintenance.

Decrease contamination

The Woulff bottle captures contaminants from entering the system. This increases the lifetime of the system.

Protect yourself and the environment

A secondary condenser prevents solvent sucked into the vacuum pump from release into the environment. This condenser is beneficial for cases where low boiling solvents are used or when pressure values are set too aggressive.



Vacuum Pump V-300 / V-600
Why should I choose one of these pumps?

The Vacuum Pump V-300 or V-600 is an essential system component if you are looking for quiet, eco-friendly operations and the ability to distill solvents of any volume and with any boiling point.

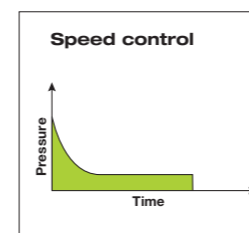

Eliminate bumping

When connected to the interface, the speed control mode of the vacuum pump ensures pressure levels are held uniformly. This not only minimizes the risk of bumping, it also reduces noise emission significantly and extends the lifetime of the pump.



Save energy

When not connected to the interface, the pump automatically switches to power savings mode after a given time interval has passed. This leads to substantial energy and cost savings.



Reduce noise levels

Thanks to speed-control, the pump operates smoothly to maintain the set vacuum. This results in very low noise emission (as low as 32 dB) and a more comfortable working environment.

Evaporate high or low boiling solvents of any volume

You can flexibly choose between two vacuum pumps according to your specific requirements.

	V-600	V-300
High boiling point (Vacuum down to 1.5 mbar)	●	–
Low boiling point (Vacuum down to 5 mbar)	–	●
Small flask volume up to 5 L (Suction capacity up to 1.8 m ³ / h)	–	●
Large flask volume up to 20 L (Suction capacity up to 3.1 m ³ / h)	●	–

Recirculating Chiller F-305 / F-308 / F-314

Why should I choose one of these chillers?

If you would like to conserve water, save time and benefit from more consistency in your distillation performance, the Recirculating Chiller F-305 / F-308 / F-314 might be just what you need.



Save time with dynamic distillations

When the chiller is connected to the Interface I-300 / I-300 Pro, distillations can begin immediately, as the pressure setting is adjusted dynamically until the set temperature of the chiller is reached. Waiting intervals are eliminated to save valuable time.



Reduce the environmental footprint of the process

The chiller consists of a circuit system with a closed loop so that the same coolant is used all the time to eliminate waste, improve sustainability and increase cost-efficiency.



Gain lasting reproducibility even in hot summers

Maintaining the cooling liquid at a constant temperature, regardless of the season, brings more efficiency and reproducibility to the distillation process. For optimal performance a temperature difference of 40 °C between the heating bath and the condenser should be maintained.



Conserve water and energy

In combination with the ECO mode of the Interface, you can save energy and conserve water by sending the chiller into stand-by mode if no distillation is taking place after a pre-defined time interval passes.

Optimize your distillation with a well-suited chiller type

A choice of three chillers helps you achieve the optimal balance between required cooling capabilities and energy savings. These are our recommendations:

	F-305	F-308	F-314
Supported lab-size rotary evaporator	1	2	3 – 4
Intense cooling required (below 0 °C)	–	●	●
Cooling capacity (@ 15 °C)	550 W	900 W	1400 W
Control by Interface I-300 / I-300 Pro	●	●	●

Rotavapor® R-300

Standard configurations

System configurations*



Professional 11SR300251VP21	Advanced 11SR300251VS11
--------------------------------	----------------------------

Your needs

High-boiling samples or volumes exceeding 1 L	●	●
High level of Automation required (Automatic distillation methods, graphical view, data collection, BUCHI Cloud Services)	●	–
Some level of Automation required (Automatic distillation)	–	●
All focus is on manual distillation	–	–
Cooling circuit already existing	–	–
Vacuum source already existing	–	–

Characteristics

Rotavapor® R-300 lift type	electronic	electronic
Interface	I-300 Pro	I-300
Heating bath capacity [L]	5	5
Heating bath max. temperature [°C]	220	220
Silent and precise Vacuum Pump V-300	●	●
Recirculating Chiller	F-308 (900 W)	F-305 (550 W)
Valve unit for external pressure source regulation	–	–

Recommended accessories**

Foam Sensor	●	●
AutoDest Sensor	●	●
Vapor Temperature Sensor	●	●
Level Sensor	●	●
Protection Shield	●	–

Stand-alone configurations*



Basic 11SR300111VS01	Professional 11R300251V151	Advanced 11R300251V141	Basic 11R300251V101
-------------------------	-------------------------------	---------------------------	------------------------

–	●	●	●
–	●	–	–
●	–	●	–
–	–	–	●
●	●	●	●
–	●	●	●

manual	electronic	electronic	electronic
I-300	I-300 Pro	I-300	–
1	5	5	5
95	220	220	220
●	–	–	–
–	–	–	–
–	●	●	–

●	●	●	–
●	●	●	–
–	●	●	–
–	–	–	–
–	●	–	–

* all configurations include 29/32 vapor duct and 220 V voltage ** Accessory article numbers can be found on page 26.

Rotavapor® R-300

Design your personalized solution

With a few simple clicks, users can easily create their own individual system that fully satisfies their unique requirements. Simply use on the QR code to obtain an order code that leads to a user-friendly configurator, select all parts and features suitable for your application and benefit from a system that has been precisely tailored to your individual needs.

System*

Define the following options using the configurator

1. Lift: Manual or electronic
2. Bath: Size and temperature
3. Joint: Size
4. Glass assembly: Type
5. Interface: Standard or professional
6. Recirculating chiller: Size and power
7. Voltage: Country dependent



* Vacuum Pump V-300 is always included
buchishowpad.com/share/hxBVD7VBuPI9Q8hv2QzTO



Stand-alone

Define the following options using the configurator

1. Lift: Manual or electronic
2. Bath: Size and temperature
3. Joint: Size
4. Glass assembly: Type
5. Protective glass coating: Standard glass or P+G coating
6. Interface: for BUCHI or external vacuum supply
7. Voltage: Country dependent



buchishowpad.com/share/hxBVD7VBuPI9Q8hv2QzTO



Rotavapor® Accessories

Expert solutions to common challenges

The Rotavapor® system has been carefully developed to solve common issues encountered during laboratory evaporation. From sticky to foamy samples, from time-consuming to risky distillations, find out how a Rotavapor® accessory can help you overcome your particular distillation challenge.



Challenge: Foamy samples

Solution: The unique foam sensor of the R-300 automatically detects and removes foam. The detector safeguards the sample and the distillate, while saving time by reducing the need for supervision or manual interference. – Order code: 11061167



Challenge: Overflow incidents

Solution: A revolutionary level sensor in combination with an interface and vacuum pump can alert the user when certain levels in the primary or secondary condenser receiving flask are reached. The device guards against overflows or facilitates the user in reaching certain concentrations. – Order code: 11060954



Challenge: Lengthy distillations

Solution: A Rotavapor® with an interface and an automatic distillation algorithm require minimal hands-on time. As pressure settings are automatically adjusted, it is also perfectly suited for work with unknown samples or sample behavior. – Order code: 11059225
Vapor sensor included in the scope of delivery.



Challenge: Checking instrument status

Solution: A bright LED StatusLight in different colors indicates if a Rotavapor® is available for use or if an error has occurred. Users can avoid wasting time by performing tedious status checks and attention is immediately drawn to any process interruptions. – Order code: 11068959



Challenge: Sticky samples

Solution: Beaker flasks are key to working with challenging samples. BUCHI's exclusive glassware equipment offers ingenious features aimed at optimizing the retrieval of valuable products and saving time with easy cleaning.



Challenge: Freeze-drying sample preparation

Solution: Robust low-temperature evaporating flasks in combination with a Dewar container speed up the preparation of freeze-drying samples, maximize sample safety and improve retention of the final product. – Order code: 11066662



Challenge: Prevent re-boiling

Solution: Follow the progress of your distillation with a vapor temperature sensor and quickly react to deviations from optimal conditions. Thanks to this progress follow, you could either prevent re-boiling and solvent release into the environment or you could load more vapor into the condenser to increase process efficiency. – Order code: 11060707



Challenge: User safety

Solution: An optional protection shield for heating baths B-301 and B-305 protects the user from heating fluid splashes, as well as glass splinters in the event of implosions. – Order code: 11061402



Challenge: Low and high boiling point solvents

Solution: Users can flexibly select between two heating bath sizes. A 1 L heating bath is suitable for applications that require bath temperatures below 95 °C, whereas a 5 L heating bath for temperatures of up to 220 °C. The 5 L bath can be used with water or oil as the heating medium.

11B305002 (5 L, 110 - 120 V)	11B305001 (5 L, 220 - 240 V)
11B301002 (1 L, 110 - 120 V)	11B301001 (1 L, 220 - 240 V)



Services and Training



Quick and effortless updates

The BUCHI product firmware is continuously improved and new features are constantly added. With the BUCHI Monitor App in combination with the BUCHI Bluetooth® Dongle your Rotavapor® System can be upgraded with a simple download of the latest update on your mobile phone.



Use your product most effectively

We help you to set your product properly into operation. We provide thorough Installation/Operation Qualification (IQ/OQ) services to ensure compliance with FDA, GLP/GMP standards or GAMP guidelines. Whether it is because of an initial installation, requalification or relocation, we provide professional compliance verification.

www.buchi.com/support/contact

Complete your portfolio



Evaporation

We offer dedicated solutions for laboratory rotary evaporation for R&D or quality control. Based on our experience and knowledge, we offer tailor-made solutions to cover a wide range of distinct needs and achieve highest convenience.

Chromatography

Whatever the complexity or the scale of your purification process is, the BUCHI preparative chromatography systems are designed to fulfill your changing needs. Together with a broad range of high performance flash chromatography columns, we provide you the optimized solution suited to your purification workflow.

Freeze Drying

Our first laboratory Freeze Dryer with Infinite-Technology™ and Infinite-Control™. Applications range from R&D to quality control within a broad spectrum of market segments. Our solutions stand out by their efficiency and practical capability.

Melting Point

To determine your melting and boiling points with high accuracy, visual or automatic determination and optional qualification packages meeting highest regulatory standards.

Core messages to our customers

BUCHI creates added value

“Quality in your hands” is the guiding principle that shapes our philosophy and our actions. It challenges us to provide outstanding services that are precisely tailored to your needs. This means that we must stay in close contact with our customers. That is why we keep in touch and continue to work very hard to understand you and your business even better.

We help you by providing high-quality products, systems, solutions, applications and services that offer you added value. This allows you to focus entirely on your processes and your work.



Competent

We have the technological expertise and decades of experience needed to provide competent support and work with you to continually improve our services.



Reliable

We guarantee the quality and functionality of our equipment and will continue to help you quickly and efficiently whenever something does not operate to your satisfaction.



Safe

By collaborating closely with you, we do everything in our power to make our products, systems, solutions, applications and services as safe as possible for people and the environment.



Cost-effective

We strive to create a high level of economic benefit and maximum added value for you.



Global

As an international family-owned business with own subsidiaries and qualified distributors, we have a presence wherever you are located.



Easy

We support you by providing carefully designed solutions as well as instruments and systems that are easy to operate.



Sustainable

We support environmentally friendly processes and manufacture products that have a long service life. We utilize advanced technologies to leave the smallest environmental footprint possible.

We are represented by more than 100 distribution partners worldwide.
Find your local representative at:

Quality in your hands





Use the above details to contact us if this literature doesn't answer all your questions.

Pricing on any accessories shown can be found by keying the part number into the search box on our website.

The specifications listed in this brochure are subject to change by the manufacturer and therefore cannot be guaranteed, please provide these to our sales team so that details can be confirmed.

