

---

# **250 - 450 Sonifier Analog Cell Disruptor User's Manual**

EDP 100-413-016  
Rev. B

**BRANSON Ultrasonics Corporation**  
41 Eagle Road  
Danbury, Connecticut 06813-1961 U.S.A.  
(203) 796-0400  
<http://www.sonifier.com>

---

# **BRANSON**

---

## **Manual Change Information**

At Branson, we strive to maintain our position as the leader in ultrasonic plastics joining, cleaning and related technologies by continually improving circuits and components in our equipment. These improvements are incorporated as soon as they are developed and thoroughly tested.

Information concerning any improvements will be added to the appropriate manual section(s) at the next printing. Therefore, when requesting service assistance for specific units, refer to the printing date which appears in the lower right corner of this page.

## **Patents and Copyright**

Copyright © 1998 by Branson Ultrasonics Corporation, Danbury, Connecticut, U.S.A.

All rights reserved.

---

Branson Ultrasonics Corporation equipment is manufactured under one or more of the following U. S. Patents:

4,973,876; 5,435,863, 5,855,706

---

### **NOTICE**

Sonifier® is a registered trademark of Branson Ultrasonics Corporation, Danbury, Connecticut, U.S.A. Other trademarks and service marks respectfully mentioned herein are held by their respective owners.

---

### **NOTICE**

Loctite is a registered trademark of Loctite Corporation, Newington, CT. Other trademarks and service marks mentioned herein are held by their respective owners.

---

## Regulatory Compliance

Sonifiers sold in Europe after 1/1/01 are CE compliant. They have new part numbers. They conform to EN55011, EN 61010-1, EN61000-3-2, EN61000-3-3, EN61000-4-3, EN 61000-4-6 and ENV50204. They take advantage of Branson latest System Protection and Autotune technology.

System protection constantly monitors various operating parameters of the power supply. If it senses conditions that could cause the power supply to overload it will shut the power module down. To reset the power supply after an overload condition has been sensed turn the power switch off and then turn it back on. On Digital Sonifiers the test function will reset the power module.

Autotune optimizes the operating frequency of the power supply so that it is consistent with the acoustic tooling. To facilitate the auto tune process the power supply performs a seek function upon first powering up the unit. When first powering up, the unit will perform a brief cycle at low amplitude so that the power supply can determine information about the acoustic tooling including its operating frequency.

The output meter on new CE Analog Sonifiers now reports Watts. It is no longer necessary to use the tables in the manual to determine output watts based on meter reading vs. output control setting.

On CE Digital Sonifiers amplitude is now set digitally from the front panel similar to all other operating parameters.

## **Warranty**

When used in accordance with written instructions and under normal operating conditions, Branson Ultrasonics Corp. equipment is guaranteed to be free of defects in MATERIAL and WORKMANSHIP for two (2) years from the date of original delivery by BRANSON or by an authorized representative. Any unit which proves defective during the stated period will be repaired free of charge or replaced at the sole discretion of Branson Ultrasonics Corp., F.O.B. Danbury, Connecticut, or an authorized repair station as advised by BRANSON, provided the defective unit is returned properly packed with all transportation charges pre-paid. A limited warranty as specified may apply to certain components of the equipment.

## **Warranty Exceptions**

This warranty shall not apply to equipment subjected to misuse, improper installation, alteration, neglect, accident or improper repair.

This warranty is limited to the original purchaser and is not transferable.

Horns and tips fabricated by Branson for use in equipment described in this manual are manufactured to exacting parameters. Using altered or modified horns and tips or horn and tips otherwise unqualified by Branson can produce undue stresses that may damage the equipment. Equipment failures resulting from using unqualified horns and tips are not covered by the Branson warranty.

Microtips are designed to give maximum mechanical energy output. Since they operate close to the stress limits of titanium, Branson cannot guarantee Microtips against failure.

**CONTACT YOUR BRANSON REPRESENTATIVE OR BRANSON ULTRASONICS CORPORATION, DANBURY, CONNECTICUT, SHOULD YOU HAVE ANY QUESTIONS CONCERNING HORN QUALIFICATION.**

1-800-732-9262

# **BRANSON**

---

---

## Table of Contents

---

<b>1</b>	<b>Safety and Support</b>	1-1
1.1	For Safety of Operating Personnel	1-1
1.2	About this Manual	1-1
1.3	Purpose of the Equipment	1-2
1.4	Main Components	1-2
1.5	Principle of Operation	1-3
<b>2</b>	<b>Introduction</b>	2-1
2.1	250/450 Sonifier Power Supply Front Panel	2-1
2.2	Model 250/450 Sonifier Power Supply Rear Panel	2-3
2.3	Specifications	2-4
2.3.1	Electrical Specifications	2-4
2.3.2	Mechanical Specifications	2-5
2.3.3	Dimensions	2-5
<b>3</b>	<b>Delivery and Handle</b>	3-1
3.1	Unpacking and Handling	3-1
3.2	Placement of Equipment	3-1
3.3	Power Requirements	3-2
3.4	Setup Procedure	3-3
<b>4</b>	<b>Operation</b>	4-1
4.1	General Operation	4-1
4.1.1	Timed Operation	4-1
4.1.2	Continuous Operation	4-2
4.1.3	Pulsed Operation	4-2
4.2	Operating Considerations	4-3
4.2.1	Limiting Temperature Rise	4-3

4.2.2 Vessel Capacity and Speed of Temperature Rise - -	4-4
4.2.3 Minimizing Undesirable Factors - - - - -	4-5
4.2.4 Sterilizing and Preventing Cross-Contamination - -	4-6
4.2.5 Disrupting Tissues and Solids- - - - -	4-6
4.2.6 Using Glass Powders with Solution - - - - -	4-7
<b>4.3 Testing the Equipment- - - - -</b>	<b>4-7</b>
<b>4.4 Connecting and Removing Tips, Horns, and Converters - -</b>	<b>4-8</b>
4.4.1 Connecting Horn to Converter - - - - -	4-8
4.4.2 Connecting Tip to Horn - - - - -	4-8
<b>4.5 Horn and Micro Tip Amplitudes- - - - -</b>	<b>4-10</b>
<b>5 General Information - - - - -</b>	<b>5-1</b>
<b>5.1 General Information - - - - -</b>	<b>5-1</b>
5.1.1 System Trouble Analysis Chart - - - - -	5-1
<b>6 Main Electrical Assembly - - - - -</b>	<b>6-1</b>
<b>250/450 Sonifier Assembly 6-2</b>	
<b>6.2 250 Power Supply Parts List - - - - -</b>	<b>6-3</b>
6.2.1 Domestic 100-132-1622 - - - - -	6-3
<b>6.3 450 Power Supply Parts List - - - - -</b>	<b>6-4</b>
6.3.1 Domestic 100-132-1623 - - - - -	6-4
<b>6.4 250/450 Sonifier Interconnect Schematic - - - - -</b>	<b>6-5</b>
<b>A The Effects of Ultrasonic Irradiation on Various Biological Materials- - - - -</b>	<b>A-1</b>
<b>B How to obtain Further Assistance- - - - -</b>	<b>B-1</b>
<b>Customer Service, Technical Support, and Applications Assistance</b>	
- - - - -	B-1
<b>Equipment Failure Support - - - - -</b>	<b>B-1</b>
<b>Returning Equipment - - - - -</b>	<b>B-1</b>



<b>C</b>	<b>Accessories</b>	- - - - -	C-1
	Micro Tip	- - - - -	C-1
	Cup Horn	- - - - -	C-2
	Flow-thru Horn	- - - - -	C-3
	Rosette Cell	- - - - -	C-3
	Continuous-Flow Attachment	- - - - -	C-4
	Soundproof Box	- - - - -	C-4
<b>D</b>	<b>Accessories Parts List</b>	- - - - -	D-1
	Accessories Parts List	- - - - -	D-1

---

## List of Figures

---

fig. 1.1	Model 250/450 Sonifier Main Components - - - - -	1-3
fig. 2.1	Supply Front Panel- - - - -	2-1
fig. 2.2	Power Supply Rear Panel - - - - -	2-3
fig. 2.3	250/450 Sonifier Side View Dimensions - - - - -	2-5
fig. 2.4	250/450 Sonifier Front View Dimensions - - - - -	2-5
fig. 3.1	Converter/Horn Assembly in Stand.Set ON/OFF switch to OFF - - - - -	3-3
fig. 4.1	Methods For Connecting/Removing Horn From Converter	4-8
fig. 4.2	Connection or Removing Tip and Horn - - - - -	4-9
fig. 6.1	240/450 Sonifier Assembly Drawing - - - - -	6-2
fig. C.1	Soundproof Box - - - - -	C-4

---

## **List of Tables**

---

tab. 2.1	Front Panel Device and Function - - - - -	2-2
tab. 4.1	Temperature Rise Variations - - - - -	4-4
tab. 4.2	Horn Amplitude Table - - - - -	4-10
tab. 4.3	Microtip Amplitudes- - - - -	4-11
tab. 5.1	Symptom/Probable Cause - - - - -	5-1
tab. 6.1	Power Supply Parts 100-132-1622 - - - - -	6-3
tab. 6.2	Power Supply Parts 100-132-1623 - - - - -	6-4
tab. D.1	Accessories Parts List - - - - -	D-1



---

# Chapter 1: Safety and Support

---

1.1 For Safety of Operating Personnel	1-1
1.2 About this Manual	1-1
1.3 Purpose of the Equipment	1-2
1.4 Main Components	1-2
1.5 Principle of Operation	1-3

## 1.1 For Safety of Operating Personnel

1 Make sure that the equipment is properly grounded DO NOT operate if it is not.

2 The unit is equipped with a three-conductor cord and three-prong grounding-type plug and must be plugged into a three-prong ground-type wall receptacle. DO NOT under any circumstances remove the power cord ground prong.

3 DO NOT operate equipment with the cover removed. High voltage is present within the equipment when connected to plant wiring.

4 Do not allow the horn or micro tip to contact lab stands, beakers, etc. or horn/micro tip failure may result.

5 Establish a standard of operation and periodically test equipment, as described in Section 4.3.

## 1.2 About this Manual

This manual contains operation and service instruction for the Sonifier cell disruptor Model 250/450. It contains background information essential to the proper use and care of this equipment.

The following definitions apply in this manual:

---

**NOTICE**

Inconvenience only if disregarded - no damage or personal injury.

---

---

**CAUTION**

Equipment damage may occur, but not personal injury.

---

---

**WARNING**

*Personal injury may occur - DO NOT DISREGARD.*

---

### **1.3 Purpose of the Equipment**

The 250/450 Sonifiers can be used to disrupt cells, bacteria, spores, or tissue, and are ideal for initiating and accelerating chemical, biochemical and physical reactions, and degassing liquids. With the 250/450 Sonifiers, you can prepare an emulsion to .01 micron, homogenize immiscible liquids, polymerize some materials and de polymerize others. Appendix B lists the effects of irradiating a variety of biological materials with ultrasonic energy at 20 kHz.

The 250 and 450 Sonifiers differ in their output power ratings with the output control at maximum setting. The 250 maximum available output power is 200 watts, the 450 maximum available output power is 400 watts.

### **1.4 Main Components**

The main components of the 250/450 sonifiers are the power supply, the converter and the horn, shown in figure 1, below.

**Figure 1.1** Model 250/450 Sonifier Main Components



## **1.5 Principle of Operation**

The power supply converts AC line voltage to 20kHz electrical energy. This high-frequency electrical energy is fed to a converter where it is converted to mechanical vibrations. The heart of the converter is a lead zirconate titanate electrostrictive element which, when subjected to an alternating voltage, expand and contracts. The converter vibrates in a longitudinal direction and transmits the motion to the horn tip immersed in the solution.

The implosion of microscopic cavitation in the solution results, causing the molecules in the medium to become intensely agitated.

The Sonifier functions in two modes - Pulsed and Continuous. In Pulsed Mode, ultrasonic vibrations are transmitted to a solution at a rate of one pulse per second. This pulse duration can be adjusted from 0.1 to 0.9 per second, enabling a solution to be processed at full ultrasonic intensity, while limiting temperature build-up - especially valuable when processing heat-volatile solutions and temperature-sensitive material.

In Continuous Mode, the Sonifier can be set up for continuous duty.

The 200 and 400 Watts output power specified for the Models 250 and 450, respectively, is their maximum power capability. The actual power developed for any application will depend upon the load on the horn face.

The Sonifier is a constant amplitude device, i.e. as the load or pressure on the horn face increases, the power supply will develop more power to maintain the amplitude for any given output control setting. When the horn is operated in air, the horn is subjected to minimum pressure and minimum power.

The load will increase when the horn is immersed in a liquid, the more viscous the liquid, the higher the load and the more power required. If a flow through cell which can be pressurized is used, thereby applying pressure on the horn, even more power will be required.

For any given application, more power will result when a horn of higher amplitude or with larger radiating surface is used or when any horn is driven at higher amplitude by increasing the output control setting.



---

# Chapter 2: Introduction

---

2.1 250/450 Sonifier Power Supply Front Panel - - - - - 2-1  
2.2 Model 250/450 Sonifier Power Supply Rear Panel - - - - - 2-3  
2.3 Specifications - - - - - 2-4  
    2.3.1 Electrical Specifications - - - - - 2-4  
    2.3.2 Mechanical Specifications - - - - - 2-5  
    2.3.3 Dimensions - - - - - 2-5

## 2.1 250/450 Sonifier Power Supply Front Panel

Figure 2.1 Supply Front Panel

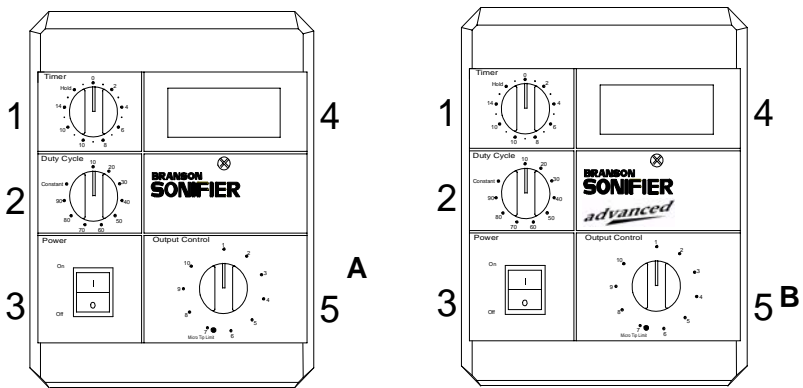

---

**NOTICE**

Both illustrations represent a Sonifier Power Supply Front Panel with the exception that the image shown as B is intended for use in Japan.

---

**Table 2.1** *Front Panel Device and Function*

<b>Item</b>	<b>Device and Function</b>
<b>1 Timer</b>	<ul style="list-style-type: none"><li>• Times the application of ultrasonic energy, 0 to 15 minutes, or to HOLD. Use HOLD in either the PULSED or CONTINUOUS Modes, if you require an undetermined exposure time, and ultrasonic energy will be on indefinitely. Set the timer anywhere from 0 to 15 minutes to either PULSED or CONTINUOUS Modes, and ultrasonic energy will switch off at the end of the predetermined period.</li></ul>
<b>2 Duty Cycle dial</b>	<ul style="list-style-type: none"><li>• In the PULSED Mode, the ultrasonics are pulsed at a fixed repetition rate of one pulse per second. The Duty Cycle control varies the duration of the ultrasonic pulse. For example, if you choose a 10% setting, ultrasonics will be on for 10% of every second, if you choose a 90% setting, ultrasonics will be on for 90% of every second.</li></ul>
<b>3 ON/OFF Switch</b>	<ul style="list-style-type: none"><li>• Applies main power to the unit. Lights when power is on.</li></ul>
<b>4 Loading Meter</b>	<ul style="list-style-type: none"><li>• Indicates level of ultrasonic power delivered to your sample.</li></ul>
<b>5 Output control</b>	<ul style="list-style-type: none"><li>• Controls the amplitude i.e. peak to peak motion, of the ultrasonic vibrations. Clockwise rotation increases amplitude. For further information, refer to Figures 6 and 7, Power Outputs Charts.</li></ul>

**NOTICE**

When using micro tips, maximum output control setting is 7.

## 2.2 Model 250/450 Sonifier Power Supply Rear Panel

Figure 2.2 Power Supply Rear Panel

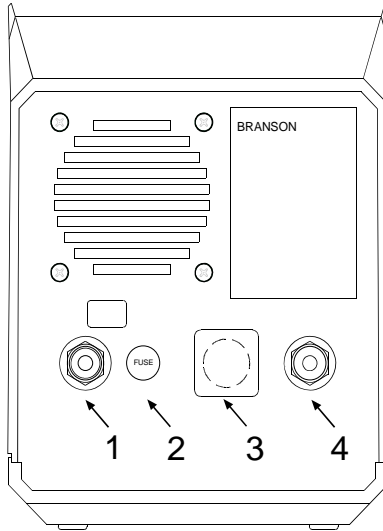

**Table 2.2** Rear Panel Device and Function

Item	Device and Function
1 Power Cord	• Connects the power supply to an electrical outlet.
2 Fuse (4 AMP)	• Overload Protection
3 6-Pin Connector	• Accessory connector.
4 RF Cable	• Connects the power supply to the converter.

## 2.3 Specifications

### 2.3.1 Electrical Specifications

*Table 2.3 Electrical specifications*

<b>Controls &amp; Displays</b>	<ul style="list-style-type: none"><li>• Timer: 0-15 Minutes and Hold;</li><li>• Output control: Duty Cycle;</li></ul>
<b>ON/OFF Switch</b>	<ul style="list-style-type: none"><li>• Pilot Light</li></ul>
<b>Output control</b>	<ul style="list-style-type: none"><li>• Adjusts amplitude of power supply output voltage.</li><li>• Range: 10% - 100% of nominal converter amplitude.</li></ul>
<b>Duty Cycle</b>	<ul style="list-style-type: none"><li>• Intermittent- pulse duration adjustable 10% - 90%, 1 pulse per second.</li><li>• Continuous Processing Time</li></ul>
<b>Connector</b>	<ul style="list-style-type: none"><li>• RF: connects 20kHz, high voltage to converter connections (Model 102C).</li></ul>
<b>Horn Frequency</b>	<ul style="list-style-type: none"><li>• 19.850 - 20.050 kHz</li></ul>
<b>Line Voltage</b>	<ul style="list-style-type: none"><li>• 100V <math>\pm</math> 10V, 50/60 Hz. 115V <math>\pm</math> 10V, 50/60 Hz. 200 - 250 (selectable), 50/60 Hz. Maximum ground leakage current (115V line to ground) =1.2ma.</li></ul>
<b>Power Minimum acceptable output power</b>	<ul style="list-style-type: none"><li>• Model 250, 150 Watts.*</li><li>• Model 450, 350 Watts.*</li></ul>
<b>Minimum Starting Power</b>	<ul style="list-style-type: none"><li>• Model 250, 120 Watts.*</li><li>• Model 450, 300 Watts.*</li></ul>
<b>Temperature</b>	<ul style="list-style-type: none"><li>• Operating: 41°F (5°C) 122°F (40°C)</li><li>• Ambient Storage and Shipping: 22°F (-30°C) to 158°F (70°C)</li></ul>
<b>Tuning</b>	<ul style="list-style-type: none"><li>• Factory set, no tuning necessary.</li></ul>

\*Output control at maximum setting.

### 2.3.2 Mechanical Specifications

**Table 2.4** Mechanical specifications

<b>Converter</b>	<ul style="list-style-type: none"><li>• Weight: 4 lbs (1.8 kg) with horn</li><li>• Dimensions: 7" L x 2 1/2" dia. (180 x 60 mm)</li></ul>
<b>Horn</b>	<ul style="list-style-type: none"><li>• Tip Diameter: 1/8" - 1" (3.2 - 25mm) dia. depending on process needs.</li></ul>
<b>Power Supply</b>	<ul style="list-style-type: none"><li>• Weight: 15 lbs (6.8 kg)</li></ul>

### 2.3.3 Dimensions

**Figure 2.3** 250/450 Sonifier Side View Dimensions

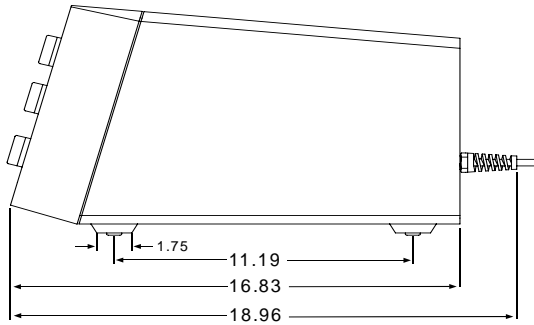

**Figure 2.4** 250/450 Sonifier Front View Dimensions

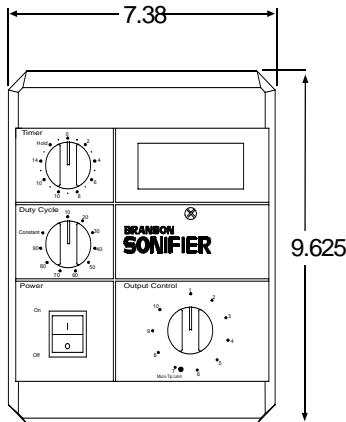



---

## Chapter 3: Delivery and Handle

---

<b>3.1 Unpacking and Handling</b>	- - - - -	3-1
<b>3.2 Placement of Equipment</b>	- - - - -	3-1
<b>3.3 Power Requirements</b>	- - - - -	3-2
<b>3.4 Setup Procedure</b>	- - - - -	3-3

### 3.1 Unpacking and Handling

Unpack the model 250/450 Sonifier unit as soon as it arrives. Normal precautions in unpacking and reasonable care in handling should be exercised to avoid possible damage to the unit. Visually inspect all external controls, indicators and surfaces to detect any damage which might have occurred during shipment.

The shipping company is responsible for damage to equipment during shipment. If damage has occurred, notify the shipping company immediately to establish proper basis for claim.

---

**NOTICE**

In case of damage, do not discard packing material until shipping company has inspected for cause of damage.

---

### 3.2 Placement of Equipment

Install the unit in an area away from radiators or heating vents.

A fan maintains safe operating temperatures in the power supply by circulating air over the components. Therefore, place the power supply so that the air intake located on the bottom of the power supply is not blocked.

If the temperature within the unit becomes excessive, a thermal cutout switch will disconnect the power and keep it disconnected until the ambient temperature cools to a safe operating level. Although the unit will automatically be re-energized when a safe operating temperature has been reached, it should be checked to determine the reason for the initial cutout. Periodically, unplug the unit and clean the air intake underneath the power supply to ensure that dust or dirt is not restricting the flow of air.

### **3.3 Power Requirements**

The Sonifier unit requires a single-phase, three wire, 117V or 200-245V 50/60 Hz source. The line cord is equipped with a NEMA 5-15P plug and requires a NEMA 5-15R receptacle



*To prevent the possibility of electrical shock, always plug the Sonifier unit into a grounded power source.*

---



### 3.4 Setup Procedure



**Figure 3.1** Converter/Horn Assembly in Stand. Set ON/OFF switch to OFF

- a. Plug the line cord into an appropriate electrical power outlet ensuring that the power supply is grounded to prevent possibility of an electrical shock.
- b. Ensure that the horn is screwed into the converter and tightened adequately. Remember to use washer in between Horn and Converter. The recommended torque is 220 inch pounds (24.85Nm)
- c. Mount converter/horn assembly in a laboratory stand or Branson sound enclosure as shown in [Figure C.1](#). Secure clamp on converter.
- d. Ensure that the tip is screwed into the horn and tightened adequately. Recommended torque is 90 in-lbs (10.16Nm) for a flat tip with 1/4-20 threads.

---

**NOTICE**

To remove a horn, use the spanner wrenches supplied. See Section 4.4

---



---

## Chapter 4: Operation

---

<b>4.1 General Operation</b>	4-1
4.1.1 Timed Operation	4-1
4.1.2 Continuous Operation	4-2
4.1.3 Pulsed Operation	4-2
<b>4.2 Operating Considerations</b>	4-3
4.2.1 Limiting Temperature Rise	4-3
4.2.2 Vessel Capacity and Speed of Temperature Rise	4-4
4.2.3 Minimizing Undesirable Factors	4-5
4.2.4 Sterilizing and Preventing Cross-Contamination	4-6
4.2.5 Disrupting Tissues and Solids	4-6
4.2.6 Using Glass Powders with Solution	4-7
<b>4.3 Testing the Equipment</b>	4-7
<b>4.4 Connecting and Removing Tips, Horns, and Converters</b>	4-8
4.4.1 Connecting Horn to Converter	4-8
4.4.2 Connecting Tip to Horn	4-8
<b>4.5 Horn and Micro Tip Amplitudes</b>	4-10

### 4.1 General Operation

In general, starting conditions are as follows:

#### 4.1.1 Timed Operation

Turn timer control clockwise to the desired processing time. Set Duty Cycle Control to Constant and Output Control to 1.

With the tip of the horn immersed about 1/4 to 1/2 inch in the solution to be processed, turn power switch to ON. To increase ultrasonic intensity turn Output Control clockwise to the next highest number pausing at each setting in order to evaluate results until the optimum setting is reached.

### **4.1.2 Continuous Operation**

Turn Timer Control fully clockwise to the Hold position. Set Duty Cycle Control to Constant and Power Switch to On. Adjust Output Control to the desired required intensity.

### **4.1.3 Pulsed Operation**

Use of the Duty Cycle control enables the ultrasonic energy to be pulsed, one pulse per second. The control settings from 10 to 90 changes the duration of the pulse from 10% to 90% of each second respectively. Pulsing the ultrasonic energy retards the rate of temperature increase in the solution that results from the ultrasonic activity.

To operate in the pulsed mode, set the Timer control to Hold if the process is not to be timed or a processing time of longer than 15 minutes is required. Set Duty Cycle Control to the required pulse duration. The lower number setting the shorter the pulse, and the slower will be the temperature rise of the solution. Switch power On and adjust Output Control to the required intensity.

---

**NOTICE**

Prior to processing an unknown sample, estimate variables such as processing time, output control setting, starting temperature, and maximum permissible temperature of sample.

---

---

**NOTICE**

Remember that the temperature of a liquid will rise from the effect of ultrasonically induced cavitation.

---

---

**NOTICE**

First, process a small sample of the specimen using your estimated control variables. When unsure, initial test should be conducted with short time and low amplitude setting.

---

**NOTICE**

Examine the results against your objective. Several trial runs may be necessary. Based on results obtained, adjust the variables until you obtain satisfactory results, experimenting with one variable at a time.

---

**CAUTION**

When using micro tips, do not advance the output control beyond 7, or permanent damage to the micro tips can result. Do not allow micro tips to touch anything other than the solution. The stress of touching the glass container can cause fracture of the tip or container.

---

## 4.2 Operating Considerations

The following sections discuss operating techniques under varying conditions.

### 4.2.1 Limiting Temperature Rise

An important objective in ultrasonic emulsification is to keep processed samples cool. Selection of the proper processing vessel and cooling bath resolves most heating problems. While any type of vessel can be used to hold the sample, the shape of the vessel depends primarily on the volume to be processed. For small volumes, choose the smallest diameter vessel that allows the probe to be inserted without touching the sides of the vessel. This minimized diameter size raise the height of the liquid, permitting greater surface area to be exposed to the cooling bath for more effective heat transfer.

Based on heat transfer characteristics, the following vessel materials are recommended, listed in decreasing order of heat conductivity:

- |         |   |
|---------|---|
| Best    | <ul style="list-style-type: none"><li>• Aluminum</li><li>• Stainless Steel</li><li>• Thin-wall Glass</li><li>• Thick-wall Glass</li></ul> |
| Poorest | <ul style="list-style-type: none"><li>• Plastic</li></ul>   |

Immersing the processing vessel in a simple ice-water bath (0 C) provides sufficient cooling for larger volumes, if required treatment times are short. If temperature rise is too great with this method, consider using the following:

- Ice-salt (-6 C) - Ice-alcohol (-14 C)
- Dry-ice alcohol-water (-30 to -40 C)

For smaller volumes with less than 30 seconds treatment time, an ice-water bath is sufficient. For longer periods, especially when high power is required, a lower temperature bath is required.

**4.2.2 Vessel Capacity and Speed of Temperature Rise**

The smaller the volume, the more difficult the cooling procedure becomes. For example, using any given power input, to treat 5 ml for a long period, would require a cooling bath of approximately -35 C to maintain the sample at or below 5 C. In comparison, the processing of 200 ml would require a cold bath of only 0 C.

Table 4-1 shows typical temperature rises for sample sizes of 25 ml and 100 ml, using a 250 Sonifier. A polyethylene container was used, with a 1/2” (12.7 mm) diameter probe with a probe depth of 1/2 inch (12.7 mm), and a starting temperature of 25°. “Average Diff.” was the average difference among duplicate runs.

**Table 4.1** *Temperature Rise Variations*

Sample Size	25 ml			100ml		
Power Level	3	7	10	3	7	10
Seconds	Temperature after sonic time					
30	30°	35°	42°	26.5°	27.5°	29.3°
60	34°	45°	55.6°	27.5°	30.3°	33.5°
120	42°	61°	78°	30°	35°	41.3°
180	48.5°	74°	90°	32°	39.3°	48°
240	54.5°	82.5°	95°	34°	44°	54.5°
300	60°	88	95°	36°	48°	60°
Average Diff	±0.7°	±0.4°	±0.4°	±0°	±0.2°	±1.6°

### **4.2.3 Minimizing Undesirable Factors**

Other factors may be detrimental to enzyme or biological activity and can reduce the effectiveness of ultrasonic processing. Minimize undesirable factors, as follows:

#### **4.2.3.1 Foaming or Aerosoling**

Always place the horn deep enough below the surface of the liquid to ensure there is no violent motion or agitation on the surface. This problem is more critical when processing small volumes, for example, 0.3 to 5 ml, when a conical-shaped tube or vial, such as a cut-down Eppendorf tube, is recommended. The conical shape of this type of container effectively raises the liquid level without increasing the volume, thereby permitting the horn to be inserted more deeply below the liquid surface level.

If foaming occurs, it can be detected by a change in the sound level and a fluctuating reading on the power meter.

Little or no energy couples reliably to the solution while aerosoling is occurring, and excessive top-layer heating will result. Remedy this problem by lowering the probe as deep as possible and placing the output power control to position 1 or 2 for a few seconds. Then gradually advance the power output control to the level required.

#### **4.2.3.2 Tip Erosion**

Horn tips can erode. Tip erosion is a side effect of the cavitation process that occurs when liquids are submitted to ultrasonic energy. The rate of erosion depends on the intensity of power applied, corrosiveness of the liquid being treated, and the amount of use.

Erosion accumulates, increases, and accelerates unless corrected in its early stages. Recognize erosion early by periodically inspecting the tip. Starting from a polished or shiny state, the tip changes to light grey, then dark grey, then concentric rings appear. Finally, the tip becomes very rough and pitted, resulting in power output loss. The tip can also discolor or darken the solution by introducing metal particles into it.

When the tip begins to turn to a medium grey color, polish the grey area with a very fine crocus cloth. To do this, the tip or horn does not have to be removed from the converter, place the crocus cloth on a flat surface, hold the lower portion of the horn and rub it on the cloth for a few seconds to restore the original polish to the tip. If the horn is also pitted, use very fine emery cloth to remove the pits first.

### **4.2.3.3 Power Output Loss**

If you observe a loss in power, several factors can be the cause. Ensure that the tip is not corroded and is polished, as noted in the preceding paragraph.

If the horn has a replaceable tip, remove the tip and clean its threads in alcohol. Place the horn in a container of alcohol and turn the power on for a few seconds to clean the interior threads. Remove the horn from the alcohol. Operate the horn in air for a few seconds to dry the tip and threads, which must be thoroughly dry and clean prior to reassembly.

Using a spanner wrench on the horn and an open-end wrench on the tip, install the tip tightly using the following torque specifications:

- 1/4 - 20 -- tighten at 90 inch-lbs./10.16 Newton-meters.
- 1/4 - 28 -- tighten at 110 inch-lbs./12.42 Newton-meters.
- 3/8 - 24 -- tighten at 180 inch-lbs./20.33 Newton-meters.

The 250/450 Sonifier does not require retuning.

### **4.2.3.4 Discoloration of the Processed Sample**

If the tip touches the side of a glass tube or beaker, small glass particles will be released which gradually discolor the sample to a greyish color. Excessive tip corrosion can also cause a greying or darkening condition.

### **4.2.4 Sterilizing and Preventing Cross-Contamination**

Sterilize horns and tips by removing them from the converter and autoclaving them. However, it is faster, easier, and equally effective, to sterilize horns by immersion in a beaker of alcohol or other disinfectant and then turning the power on for a few seconds. This technique also cleans or removes unwanted residue on the horn or tip.

### **4.2.5 Disrupting Tissues and Solids**

You can effectively homogenize or disrupt many kinds of tissue and other solids. Energy radiates only from the horn's tip. The energy is most concentrated within 1/2 inch (13 mm) of the face of the tip. When you treat tissue or solids already in solution, the freely moving cells or particles pass before the face of the tip many times during the process. When you treat a solid piece, however, the energy pattern from the tip of the horn has a tendency to push or repel the solid away from the tip. The solid does not receive treatment, but simply spins or circulates around the container.



You can effectively treat all but the most difficult of materials by the following two steps:

1. Homogenize the tissues or solids by placing them in a high-speed blender with the solution.
2. Insert the horn in the liquid sample for complete disruption.

To disrupt solid pieces, especially those that are extremely resistant to breakage, place the horn directly over the tissue or right against it.

### **4.2.6 Using Glass Powders with Solution**

To disrupt difficult cells and tissues, adding glass powders (5 microns to 0.5 mm) will materially decrease treatment tissues, especially when used in conjunction with the standard, high intensity micro tip. A ratio of 1 part glass powder to 2 parts liquid is recommended.

## **4.3 Testing the Equipment**

To establish a base line for future testing to verify if the equipment is operating properly, proceed as follows:

- e. Mount 1/2" disruptor horn (with flat tip if tapped) to converter.
  - a. Set Output Control to 5, Timer to HOLD and ON/OFF switch to ON.
  - b. Record meter reading with horn in air.

Meter Reading \_\_\_\_\_

Horn Size \_\_\_\_\_

- c. Fill 500 ml pyrex beaker to 500 ml level with room temperature tap water.
- d. Immerse horn tip halfway to 250 ml mark. Set ON/OFF switch to ON and record meter reading.

Meter Reading \_\_\_\_\_

Perform this test and compare readings periodically, to ensure that the equipment is operating satisfactorily. These readings are a base for comparison to readings taken later on. The above meter reading with horn in air should have no greater than a 10% variation when compared to any future metering readings taken with horn in air. Likewise, the above meter reading with horn tip immersed halfway to 250mL mark should have no greater than a 10% variation when compared to any future meter readings taken with the horn tip immersed halfway to 250 mL mark. If readings are not within tolerance, refer to the Trouble Analysis Chart, Section 5.

## 4.4 Connecting and Removing Tips, Horns, and Converters

### 4.4.1 Connecting Horn to Converter

The 250/450 Sonifier horns have been torqued onto the converter at the factory. Should you need to change a horn or converter, use the spanner wrench provided. NEVER attempt to remove a horn by holding the converter housing in a vise. If necessary, secure the largest portion of the horn in a soft-jawed vise. When connecting a horn to the converter, use the following procedure:

1. Clean contacting surfaces of converter and horn, and remove all foreign matter from threaded stud and threaded hole.
2. Use the Mylar washer provided, in between the converter and required probe.



*Do not apply grease to the threaded stud.*

### 4.4.2 Connecting Tip to Horn

**Figure 4.1** Methods For Connecting/Removing Horn From Converter

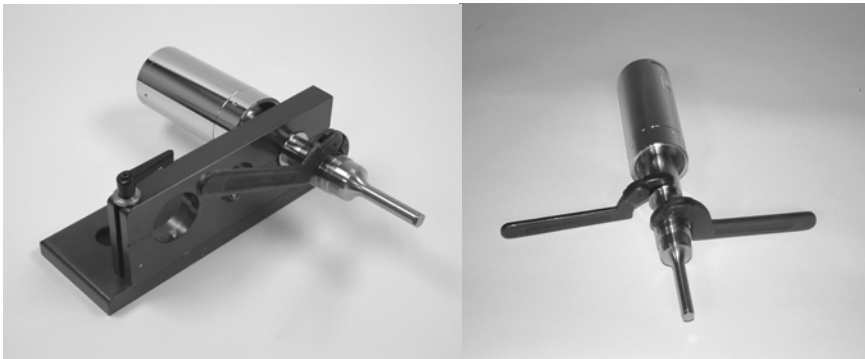

A standard flat tip, recommended for processing liquids, is supplied with tapped horns. Other tip configurations are available for experimental work on applications where the ultrasonics vibrations are transmitted directly into a solid work-piece. The shape of the horn influences the direction in which the ultrasonic vibrations are delivered from the horn. You will find a list of available tips in Appendix D, Accessories.

Attach tips to horns as follows:

1. Clean contacting surfaces of horn and tip, and remove any foreign matter from the threaded stud.

---

**WARNING**

*The tip must be installed clean and dry, or the power supply may not tune and operate correctly.*

---

2. Hand assemble tip to horn.
3. Using spanner wrench on horn and open-end wrench on tip, tighten tip. See Figure 10. Torque specifications for the various threaded tips follow:
  - f. 1/4 - 20 thread tighten at 90 inch-lbs./10.16 Newton-meters.
  - e. 1/4 - 28 thread tighten at 110 inch/lbs./12.42 Newton-meters.
  - f. 3/8 - 24 thread tighten at 180 inch-lbs./20.33 Newton-meters.

**Figure 4.2** Connection or Removing Tip and Horn



**4.5 Horn and Micro Tip Amplitudes**

*Table 4.2 Horn Amplitude Table*

Part No.	Description	Output Control Setting		
		1	5	10
101-147-037	1/2" Dia. Tapped Stepped Disruptor	21.0* .0008"	76.0* .003"	145.0* .0057"
101-147-042	1/2" Dia. Solid Catenoidal	21.0* .0008"	74.0* .0029"	145.0* .0051"
101-147-041	1/2" Dia. Solid Exponential	10.0* .0004"	34.0* .0013"	65.0* .0025"
101-147-039	3/8" Dia. Solid Stepped Disruptor	36.0* .0014"	125.0* .0049"	240.0* .0094"
100-147-043	3/4" Dia. Solid Stepped Disruptor	9.5* .0004"	33.0* .0013"	63.0* .0025"
101-147-035	3/4" Dia. Solid High Grain	19.0* .007"	68.5* .0027"	130.0* .0051"
101-147-044	1.0" Dia. Solid Stepped	6.3* .0002"	21.5* .0008"	40.5* .0016"
* All measurements in Microns.				

**Table 4.3** *Microtip Amplitudes*

Part No.	Description	Output Control Setting		
		1	5	10
101-148-062	1/8" Dia. Tapered	116.0* .0046"	306.0* .012"	494.0* .0194"
101-148-069	3/16" Dia. Tapered	59.5* .0023	183.0* .0072	302.0* .0119"
101-148-070	1/4" Dia. Tapered	59.5* .0023	151.0* .0059	247.0* .0108
101-063-212	Double Step	64.0* .0025	173.8* .0068"	274.0* .0108"
* All measurements in Microns.				



---

---

# Chapter 5: General Information

---

---

5.1 General Information - - - - - 5-1  
5.1.1 System Trouble Analysis Chart - - - - - 5-1

## 5.1 General Information

If maintenance is required, contact Branson Product Support Department, Branson Ultrasonics Corp. Danbury, Connecticut 1-203-796-0335 or 1-203-796-0551.

If you have a problem operating your unit:

1. Refer to the System Trouble Analysis Chart in this section to locate the symptom that most clearly describes your problem.
2. Use the schematics and parts lists in Section 5 to identify parts or assemblies to be checked or replaced.
3. Refer to the last page of the manual for equipment return information.

### 5.1.1 System Trouble Analysis Chart

**Table 5.1** Symptom/Probable Cause

Symptom	Probable Cause
Main power fuse fails or circuit reader trips when system is plugged into electrical outlet.	1. Line cord is shorted. 2. Switch S1 has failed. 3. Line filter has failed.

**Table 5.1** Symptom/Probable Cause

Symptom	Probable Cause
Fan does not operate. Indicator light fails to illuminate when power supply is energized.	<ol style="list-style-type: none"> <li>1. Unplugged power supply.</li> <li>2. Line cord has failed.</li> <li>3. Switch S1 has failed.</li> <li>4. Fuse F1 has failed.</li> <li>5. Line filter has failed.</li> </ol>
Fan does not operate when power supply is energized. Indicator light illuminates.	<ol style="list-style-type: none"> <li>1. Fan motor B1 has failed.</li> <li>2. Line cord failed.</li> <li>3. Switch S1 has failed.</li> <li>4. Fuse F1 has failed.</li> <li>5. Line filter has failed.</li> </ol>
Fuse F1 fails when ON/OFF switch is energized.	<ol style="list-style-type: none"> <li>1. Underrated fuse F1.</li> <li>2. Incorrect voltage.</li> <li>3. Fan motor has failed.</li> <li>4. Power Supply module has failed.</li> </ol>
Ultrasonic power is delivered to the horn. No indication on meter.	<ol style="list-style-type: none"> <li>1. Meter has failed.</li> </ol>



**Table 5.1** Symptom/Probable Cause

Symptom	Probable Cause
No or inconsistent ultrasonic power. Some indication on meter.	<ol style="list-style-type: none"><li>1. Foreign material between horn surface and replaceable tip.</li><li>2. Loose or worn out tip.</li><li>3. Horn is loose or failed.</li><li>4. Horn stud is loose or failed.</li><li>5. Converter cable has failed.</li><li>6. Converter has failed.</li><li>7. If used with a treatment chamber, horn tip may not be immersed.</li></ol>
Little or no meter indication when ON/OFF switch is energized. Fan operates.	<ol style="list-style-type: none"><li>1. Timer S3 has not been set, has completed cycle, or has failed.</li><li>2. Thermo switch SW1 is activated.</li><li>3. Pulsar board has failed.</li></ol>
Full scale or high meter deflection, horn unloaded.	<ol style="list-style-type: none"><li>1. Power supply module has failed.</li><li>2. Horn or tip have failed.</li></ol>
Power supply operates continuously but does not operate in PULSED mode.	<ol style="list-style-type: none"><li>1. Pulse mode timer or circuitry failed.</li></ol>
A slight electric shock is felt when touching the Sonifier unit.	<ol style="list-style-type: none"><li>1. Unit is improperly grounded.</li><li>2. Line cord has failed.</li></ol>



---

## Chapter 6: Main Electrical Assembly

---

<b>250/450 Sonifier Assembly</b>	- - - - -	6-2
<b>6.2 250 Power Supply Parts List</b>	- - - - -	6-3
6.2.1 Domestic 100-132-1622-	- - - - -	6-3
<b>6.3 450 Power Supply Parts List</b>	- - - - -	6-4
6.3.1 Domestic 100-132-1623-	- - - - -	6-4
<b>6.4 250/450 Sonifier Interconnect Schematic</b>	- - - - -	6-5

## 6.1 250/450 Sonifier Assembly (100-244-005, 100-244-006)

Figure 6.1 240/450 Sonifier Assembly Drawing

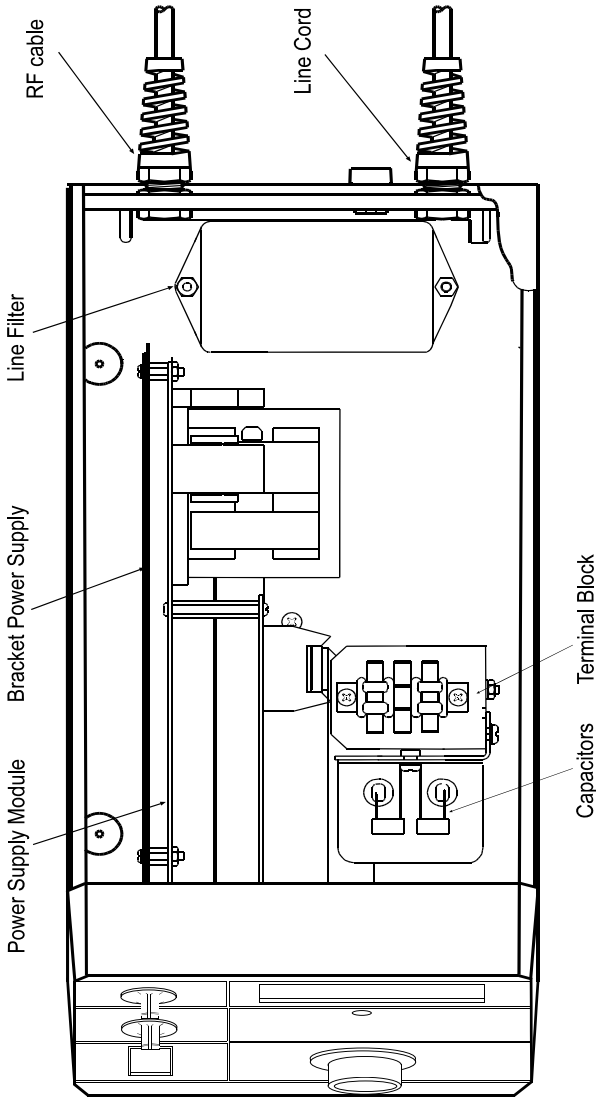

---

## 6.2 250 Power Supply Parts List

### 6.2.1 Domestic 100-132-1622

*Table 6.1 Power Supply Parts 100-132-1622*

Reference Designation	Description	Branson EDP No.
	Assembly Power Supply Module	100-244-126R
	Assembly R.F. Cable 8 ft.	100-241-345PR
	Assembly Line Cord 117V	100-241-226PR
FL1	Filter, Line 6A	200-163-033
B1	Fan	200-126-008R
F1	Fuse, 3 AG, 5 AMP	200-049-121R
M1	Meter, Panel	100-068-018R
SW1	Switch, ON/OFF	200-099-296R
	Timer	200-104-009
SW-2	Switch, Duty Cycle	200-099-170R

---

### 6.3 450 Power Supply Parts List

#### 6.3.1 Domestic 100-132-1623

*Table 6.2 Power Supply Parts 100-132-1623*

Reference Designation	Description	Branson EDP No.
	Assembly, Power Supply Module	100-244-125R
	Assembly R.F. Cable 8 ft.	100-241-345PR
	Assy Line Cord 117V	100-241-226PR
FL1	Filter, Line 6A	200-163-033
B1	Fan	200-126-008R
F1F	Fuse, 3 AG, 5 AMP	200-049-121R
M1	Meter, Panel	100-068-018R
SW1	Switch, ON/OFF	200-099-296R
SW-2	Switch, Duty Cycle	200-099-170R

### 6.4 250/450 Sonifier Interconnect Schematic

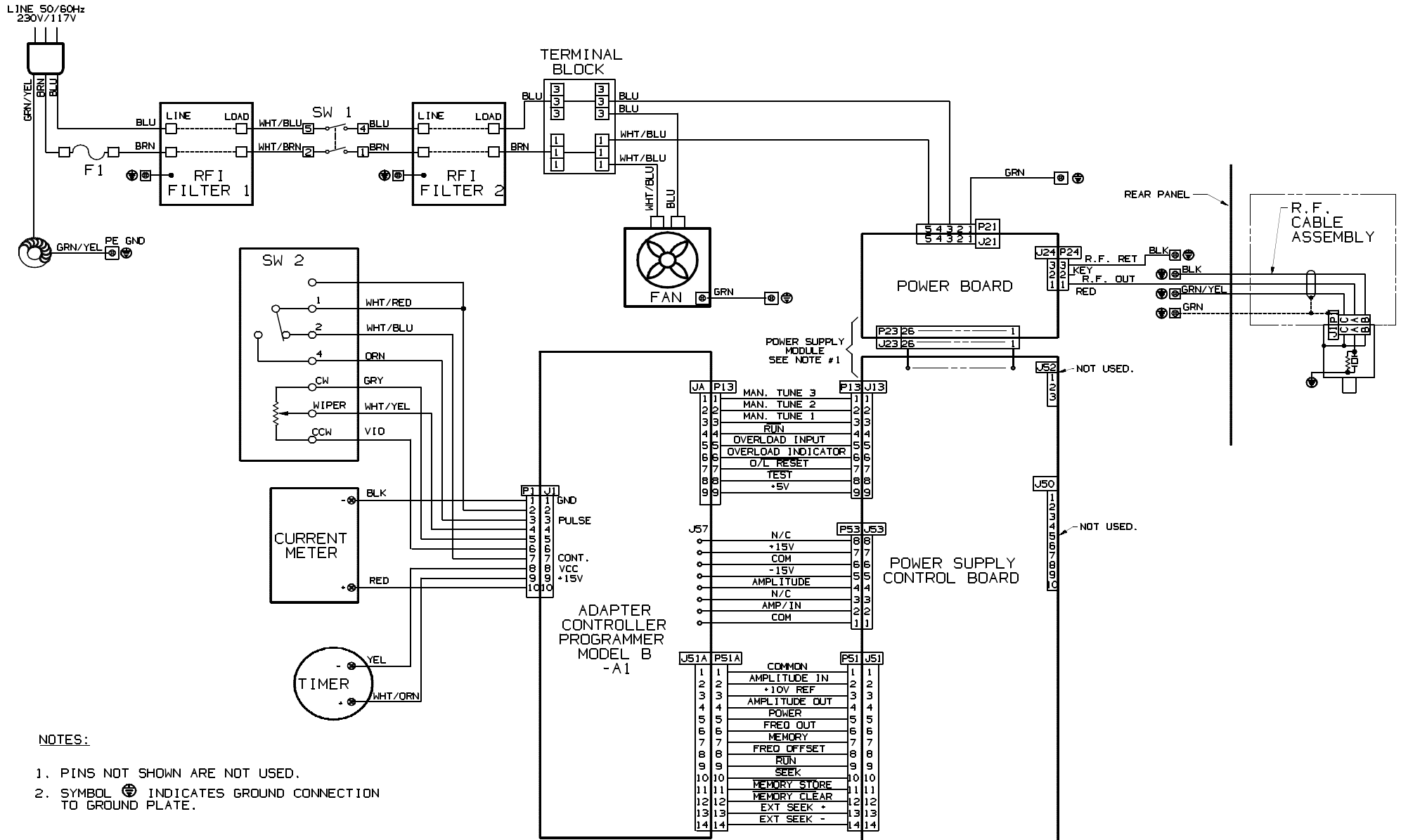





---

## Appendix A The Effects of Ultrasonic Irradiation on Various Biological Materials

---

**Actinomyces:** 3 minutes of sonifying produced excellent disruption with 50% protein released and excellent enzyme activity.

**Actinomycin D:** suspended in 3 minutes.

**Aerobacter aerogenes:** excellent breakage with better enzyme release than any other method. A low power setting can release sulfatase activity into the supernate with no obvious disruption of the majority of cells.

**Aerobacter suboxydans:** excellent breakage but requires higher power than A. aerogenes.

**Algae scenedesmus:** 10 ml concentrated solution completely disrupts in 1 minute.

**Alkaloids:** total amount and speed of extraction are greater using the Sonifier Cell Disruptor than with standard methods. Extraction from ipecac root in 30 seconds yielded more alkaloid than Soxhlet extraction in 5 hours.

**Antibioticus:** monocellular elements from surface-grown colonies obtained in 1 minute. Complete disruption in 5 minutes, 50% disruption in 2 minutes.

**Antigen:** the Sonifier Cell Disruptor is used extensively to produce antigens and vaccines. It can increase yield or expose otherwise unobtainable sites.

**Aorta:** 1 gram disintegrates in 2 minutes.

**Aphanomyces:** after blending, complete disruption in 3 minutes.

**Arthobacter tumescens:** 10 gm in 40 ml in 5 minutes for O coumaric reductase.

**Ascaris eggs:** 8 ml concentrated solution completely disrupts in 4 minutes.

**Asperigillus:** complete disruption in 4 minutes.

**Aurefaciens:** monocellular elements from surface-grown colonies obtained in 1 minute. Complete disruption in 5 minutes, 50% disruption in 2 minutes.

**Azotobacter vinelandii:** 15 ml buffered solution, 200 mg wet wt. per ml completely disintegrates in 2 minutes.

**B. anthracis:** 80% disruption of anthracis in 4 minutes. Complete disruption of 10 ml of erysipelothrix rhusipathiae in 10 minutes.

**B. cereus veg cells:** disruption in a few seconds.

**B. cereus spores:** disruption of 10 mg/6 ml in 13 minutes.

**B. megaterium spores:** complete breakage of a concentrated 6 ml solution in 15 minutes.

**B. sphaericus:** major disruption in 1-3 minutes.

**B. stereothermophilis spores:** complete disruption in 2 minutes.

**B. subtilis:** disruption of 5 gm wet wt, 15 ml buffer, in 5 minutes.

**B. subtilis veg cells:** heavy suspension clears in 1 minute.

**Bacillus:** stereothermophilus (thermophilic spore form). 98% disruption of 70 ml of 40% suspension in 15 minutes.

**Bacillus brevis:** 1:15 W/V in 3 minutes.

**Bacteroides Symbiosis:** 1-phosphofructokinase a soluble enzyme has been isolated from this anaerobe by ultrasonic treatment. A 25 ml suspension was sonified for 10 minutes and centrifuged at 36,000 xg for 10 minutes.

**Baker's yeast (saccharomyces cerevisiae):** see Yeast.

**Blastomyces dermatitidis:** 95% disruption in 3 minutes.

**Blood cells:** red and white cells can be disrupted in a few seconds.

**Boll weevil tissue:** complete homogenization in a few seconds.

**Bone:** compact bone can be sonified and processed for microscopic sections in minutes. Other methods can require up to a week. Bone specimens treated in this way yielded large numbers of intact cells with little distortion. Malignant criteria were easily recognized. Tumor types studied were: osteosarcoma, chondrosarcoma, liposarcoma, chordoma, metastatic bronchogenic squamous and benign giant. Bone can be decalcified without injury to the cells, processed for microscopic sections and diagnosed in a short time. Other methods require extensive treatment time.

**Brain stem and adrenal gland:** ultrasonic treatment dispersed 10 mg samples in 10 ml fluid which is usually difficult without substantial loss of material. The suspension was analyzed for nucleotides.

**Brain tissue:** disintegrates instantly.

**Brevi bacterium:** 25 ml disrupts in 20 seconds.

**Brevi bacterium acetylicum:** approximately 3 minutes to disrupt large samples and measure TCA enzyme activity.

**Brine Shrimp:** complete disintegration in 1 minute.

**Brucella abortus:** separates easily from leukocytes. At least 9 antigens extracted.

**Bull sperm:** contractile protein is easier to extract from tails after sonifying.

**C. butyricum, C. cylindrosporum, C. kluyveri:** vegetative cells easily disrupted.

**C. pasteurianum:** 3 minutes disruption for hydrogens reducing Ferredoxin with H<sub>2</sub>.

**Calcium:** mouse Ehrlich ascites tumor cells were sonified for 1 minute to determine the amount of bound calcium present. Cells were labelled with calcium 45.

**Candida albicans spores:** 95% disruption of 1/2 gram dry wt. in a 15 ml solution in 35 minutes.

**Carbon black:** excellent small particle suspension.

**Caryophanon latum:** glucosamine, muramic acid, alanine, glutamic acid and lysine were obtained.

**Catecholamine:**

can be extracted from heart muscle.

**Cellomonas biazotea:**

disruption obtained with retention of malate dehydrogenase activity. Chicken spermatozoa: complete disrupts in 2 minutes.

**Chlorella:**

completely disrupts in 3 minutes.

**Chloroplasts:** disrupts in a few seconds.

**Cholesterol:** apparent permanent suspension in 1 minute in water.

**Chromatography:** prior ultrasonic treatment of adsorbant in any convenient solvent for a few seconds eliminates aggregates and results in a uniform, easily packed column.

**Clostridium:** quickly disrupts all types.

**Coagulase-globulin:** ultrasonic treatment before precipitation yields significantly more enzyme.

**Collagen:** an excellent fragmentation.

**Colletotrichum capsici spores:** 5 ml with 6 million spores/ml completely disrupts in 4 minutes.

**Corticosteroid:** particle size can be reduced to approximately 5 microns while large volumes can be treated at the rate of approximately 30 ml/minute on a continuous flow basis.

**Corynebacterium:** completely disrupts in 5 minutes with 50% protein release and excellent enzyme activity.

**Cryptostroma corticale (maple bark spores):** a concentrated solution completely disrupts in 14 minutes.

**Cryptococcus laurentii:** completely disrupts in 7 minutes with good protein release and enzyme activity.

**Crystal reduction:** large crystals of an organic compound suspended in isopropanol can be reduced in diameter 10-40%.

**Cyanidium caldarium:** a concentrated solution completely disrupts in 6 minutes.

**Dental plaques:** 5 ml solution, concentration 1 to 10,000, low power setting, 53,500,000 organisms per ml were obtained in 45 seconds.

**Desulfovibrio vulgaris:** less than 30 seconds of ultrasonic treatment resulted in release of TCA enzymes.

**Diplococcus:** completely disrupts in 5 minutes.

**DNA:** breaks chains on low power instantly. Controlled degradation may be obtained.

**Dyes:** excellent rapid dispersion and homogenization.

**E. coli:** 2 gm wet wt in 10 ml solution completely disrupts in 40 seconds. The Sonifier Cell Disruptor has been used extensively in research on this organism.

**Egg whites:** can be reduced to a homogeneous pipettable solution in 15 seconds on low power.

**Ehrlich ascites:** disrupt in a few seconds.

**Electron microscopy:** apertures are quickly cleaned.

**Emulsions:** 10 ml of most light mixtures become semi-permanent emulsions in about 1 minute without emulsifiers. Average particle size is usually well under 1 micron. Sterile emulsions can be prepared by ultrasonic treatment for feeding to germ-free animals.

**Enterococcus:** excellent disruption.

**Erwina cartovara:** complete disruption in 1-2 minutes depending on cell concentration.

**Erythrocytes:** disrupts in a few seconds.

**Euglena gracilis:** completely disrupts in a few seconds to isolate chloroplasts.

**Eugoena:** complete disruption in 12 minutes, 90% disruption in 8 minutes with pigment released.

**Fat extraction:** fat can be emulsified without injuring tissue with proper power selection. Lipid layer can be stripped from spores and mycobacteria.

**Fibrin:** complete suspension of .125 gm in 30 minutes.

**Fish gill:** complete disruption of 20 mg in 30 seconds.

**Fish tissue:** tissue homogenization for extractions and excellent particle size reduction in 8 minutes per 10 gm.

**Fluorocarbons:** extended treatment time will break down particle size to well under 1 micron and gives a fine homogenate.

**Fossils:** low power will clean debris from delicate fossils without injury. Micro fossils such as pollen can be separated from rocks to help identify the geological age of the strata. Removal of rock matrix.

Gamma globulin: the Sonifier Cell Disruptor was used to solubilize protein as one of the steps in the biosynthesis of gamma globulin from rabbit spleen.

**Gangliosides:** immunochemical and structure studies used ultrasonic treatment as one step.

**Gastric mucosa:** placing scrapings into a test tube and test tube into new water-filled cup horn caps permits these cells to be separated and not broken.

**Graphite molybdenum disulfide:** an excellent dispersion of this lubricant was made in a silicate binder.

**Guanine:** produces colloidal suspension in 1 minute.

**Gymnodinium:** solution completely disrupts in 6 minutes.

**Haemophilus pertussis:** preparation of successful immunological complexes.

**Heart muscle:** 1 gm disintegrates in 6 minutes.

**HeLa Cells:** disruption to free virus in a few seconds without injury.

**Hemphilus pertussis:** an immunological compound prepared.

**Herpes virus:** may be quickly released without injury.

**Histoplasma capsulatum:** ultrasonic treatment for 7 minutes completely ruptured cells prepared by formalin fixation. Good enzyme activity was obtained.

**Human serum proteins:** ultrasonic treatment causes a reproducible change in the electrophoretic behavior of normal human serum consisting of an increase in material migrating in the x and b globulin zones with a reduction in the albumin and y globulin fractions.

**Hydrocortisone:** smaller crystals were produced by ultrasonic treatment.

**Hydrophilic vegetable gums:** disperses and solubilizes hydrophilic vegetable gums in water; makes dispersions of added particulate matter.

**Intracellular membrane:** disruption and particle size reduction obtained in 30-60 seconds.

**Isoenzymes:** selectively activated with respect to time and intensity of treatment.

**Kidney:** 1 gm disintegrates in 3 minutes.

**Kidney stones:** easily broken in seconds in vitro.

**Klebsiella:** excellent disruption.

**L. arabinosis:** complete disruption to free virus in 2 minutes without injury.

**Lactobacillus:** 0.5 gm in 15 ml completely disrupts in 11 minutes. Excellent release of acetokinase.

**Lenconostoc mesenteroides:** ultrasonic treatment for 15 minutes using high power for disruption.

**Leukocyte Iysozyme activity in myelocytic leukemia:** the cell suspension was ultrasonically treated and samples assayed for Iysozyme activity. The Iysozyme concentration of the leukocytes ug /10<sup>6</sup> cells was determined.

**Linoleic acid:** made suspension in water in 30 seconds.

**Liver tissue:** 1 gm homogenizes in less than 1 minute.

**Lung tissue:** 1 gm homogenizes in 2 minutes.

**Lymphacytis:** complete disruption in 15 seconds.

**Lymphocyte nuclei:** complete disruption in 6 minutes.

**Lymph gland:** direct injection lymphography with a modified radiopaque emulsion was obtained by ultrasonic treatment in a functional procedure producing lymphatic structure detail.

**Lysosomes:** released enzymes quickly.

**Malaria protozoa:** fast, excellent disruption.

**Maple bark spores:** complete disruption in 14 minutes.

**Measles:** disruption of virus antigen clumps present in infected cells on low power. Ultrasonic treatment increased antigen titer 4-8 fold.

**Methanobacillus omelianskii:** 1 gm cells wet wt/ml completely disintegrates in 2 minutes for assaying methane.

**Microbacterium lacticum:** ultrasonic treatment used for malate dehydrogenase extraction.

**Micrococci:** a 13 ml solution completely disrupts in 15 minutes.

**Micrococcus lactiliticus:** 75 ml of a 20% suspension was disintegrated in 15 minutes and a good yield of the enzyme Xanthine dehydrogenase extracted.

**Mineral rock:** excellent for cleaning surfaces between polishing stages.

**Mitochondria:** separates from cells without injury. Mitochondria themselves can be broken with longer ultrasonic treatment. Inner membrane sub units also isolated.

**Muscle tissue:** 1 gm homogenized in 4 minutes; heart muscle in 6 minutes.

**Mycobacteria:** a 20 ml growing media completely disrupts in 14 minutes. Clumps break quickly. An immunological compound prepared.

**Mycoplasma antibody:** a suspension of Campo-W cells treated for 5 minutes gave 12 lines with the sera in a gel diffusion test. The extract was estimated to contain 12.75 mg protein per ml by Blaret reaction.

**Myeloma tumor cells:** complete disruption in 10 minutes, 30% disruption in 2 minutes.

**Myleran:** made colloidal suspension and dissolved in approximately 1 minute.

**N. crassa:** nucleus was isolated and purified from conidial extracts after 5 minutes treatment.

**Naeglerigruberi:** this free-living soil amoeba was treated ultrasonically to release sub cellular infectious material.

**Neurospora:** 40 ml, 4 minutes, produced more protein than freeze thawing for study of enzymatic synthesis of cystathionine.

**Nocardia ostenodes:** breaks clumps and disintegrates in less than 10 minutes.

**Nucleoprotein:** extracted from tissue. May be degraded selectively.

**Oil and water emulsions:** permanent, stable emulsions in a few seconds. Particle size reduced to less than micron (each case slightly different). Oil in water/water in oil phases can be obtained in same vessel.

**Oyster shell:** small, clean hole can be drilled with micro tip in 3 minutes. No cracking is produced.

**Paracolon:** excellent disruption.

**Parasites:** separated from red cells in a few seconds.

**Pasteurella pestis:** complete disruption in 30 minutes using high power.

**Penicillium:** complete disruption in 3 minutes.

**Pesticides:** ultrasonic treatment resulted in a 16-fold improvement in the potency of the antigen used with Micro-crystalline Cellulose as a thin-layer adsorbant for chromatographic separation.

**Phosphatidate phosphohydrolase:** the most potent inhibitors for this enzyme were obtained by making five dispersions with the Sonifier Cell Disruptor.

**Phospholipid micelles:** produced stable preparations for an indefinite period.

**Plant cells:** 30% packed plant cells (W/V) and distilled water (depending on type) can be completely disrupted in 1-15 minutes.

**Plant tissue:** 1 gm dried tissue suspended in alcohol disintegrates in about 5 minutes.

**Platelets:** complete disruption according to size from 20 seconds to 4 minutes.

**Pneumococci:** preserved in formalin for several years; completely disrupts in 6 minutes.

**Polio virus:** excellent disruption of this most difficult virus.

**Powders:** broken down to a small, relatively uniform particle size.

**PPLO:** complete disruption in 2 minutes.

**Propionobacteria:** releases sulfhydro groups intact; 70 ml of 20% suspension processed for 10 minutes.

**Propionobacterium shermanii:** 2 minutes for extraction of citrate synthase.

**Proteus:** excellent disruption.

**Pseudomonas aeruginosa:** rapid, complete disintegration.



**Pseudomonas fluorescens:** 2 gm wet wt in 10 ml completely disrupts in 1 minute.

**Pulmonary cytodiagnosis:** the mucous in sputum can be evenly dispersed giving a quick representative sample of cells for cytologic examination. Cells are liberated from the mucous of sputum that had been immersed in 50% alcohol or a fixative.

**Ragweed pollen:** 15 ml dispersion completely disintegrates in 11 minutes.

**Rat bone:** 1/2 gm disintegrates in 4 minutes.

**Rat liver:** complete disruption in 3 minutes.

**Rat liver mitochondria:** ultrasonic treatment has been used extensively for the varied research performed on this material. Disruption occurs in seconds.

**Rat skin:** 1 gm completely disintegrates in 4 minutes.

**Red and white blood cells:** ultrasonic treatment breaks particle size to 100 Angstroms. Complete disruption in 1 minute. 25 gms/100 ml, saline or plasma, sample treated 15 seconds, 35% disruption. Adenosine triphosphate was shown to be membrane-bound by this method.

**Reovirus:** dissociates cell-bound and aggregated virus. Maximum titer with 4 ml of virus was achieved in 2 minutes.

**Retinal outer segments:** ultrasonic treatment breaks particles down to almost molecular size.

**Rhodopseudomonis palustris:** complete disruption in 4 minutes.

**Rhodospirillum rubrum:** excellent disruption in a few seconds.

**Rimosus:** Monocellular elements from surface-grown colonies obtained in 1 minute. Complete disruption in 5 minutes, 50% disruption in 2 minutes.

**RNA:** rapid and thorough re-suspension of 9 TCA pellets during extractions.

**Rocks:** excellent for disaggregation of sedimentary rock and for cleaning material rock surfaces between polishing stages.

**S. faecalis:** excellent disruption in 1 minute.

**S. fragilis:** 5 minutes yielded excellent release of galactokinase, more than any other method. Subcellular particles may be extracted or disrupted.

**Saliva glands:** complete disruption.

**Salmonella:** various culture media or phosphate buffered saline disintegrated between 40 and 50% in 10-20 minutes. Sonifying was one step in an improved assay for enzyme thiogalactosidase transacetylase.

**Salmonella typhimurium and enteritidis:** bacteria were suspended in 1/300 volume of original culture, sonified for 4 minutes and centrifuged for 20 minutes at 20,000 g. Extracts were found to catalyze the synthesis of cytidine diphosphate 3, 6-dideoxyhexoses.

**Schistosoma mansoni:** complete disruption.

**Sedimentary rock:** completely disperses flocs with the release of all bound silt and clay particles.

**Sediments:** ultrasonic treatment disperses fine material permitting quick, neat separation of sand from silt and clay fractions.

**Serial number restoration:** used in crime laboratories to restore obliterated serial numbers.

**Serratia marcescens:** complete breakdown of a concentrated solution in 1 minute.

**Serum:** quickly homogenized.

**Serum cholinesterase:** activated by ultrasonic treatment. Different cholinesterase isoenzymes may be activated selectively and inactivated selectively.

**Shale:** excellent disaggregation of all fine-grained sedimentary rocks.

**Shellfish:** by drilling a clean hole with the micro tip, various fluids or samples may be withdrawn or injected from living shellfish without destroying the animals.

**Shigella:** quick disruption.

**Skin:** 1 gm disintegrates in about 4 minutes. Epidermal homogenates that respire and utilize substrate can be extracted.

**Soil:** separates solid particles without use of oxidants, acids or peptizing agents and yields stable suspensions.

**Sperm (human):** tails are broken instantly. Heads are broken in 20 minutes.

**Sputum:** cancer cells are more easily detected after ultrasonic treatment due to even dispersion of cells and sputum, and complete liberation of the cells from sputum.

**Staphylococcus:** a concentrated solution disrupts 98% in 10 minutes. With 1 gm cells wet wt, to 2 gm water, 54.5 mg/ml of protein was released.

**Starch:** obtained by extracting from green plant leaf homogenate.

**Streptococcus, Group A:** a 20% suspension in a 15 ml solution completely disrupts in 15 minutes.

**Streptomyces:** monocellular elements from surface-grown colonies obtained in 1 minute. Complete disruption in 5 minutes, 50% disruption in 2 minutes.

**Subcellular particles:** may be separated or broken depending on power selection and length of time.

**Sulfanilamide:** excellent dispersion in less than 1 minute. Continued ultrasonic treatment will produce complete disruption.

**Sulfapyridine:** excellent dispersion in less than 1 minute. Continued ultrasonic treatment will produce complete disruption.

**Synovial fluid:** ultrasonic treatment is an excellent means of reducing fluid viscosity. It is simpler and faster than using hyaluronidase.

**T. pyriformis:** excellent disruption, 8 enzymes released.

**Tablets:** complete disruption in 2-40 seconds, depending on type.

**Tea:** excellent extraction.

**Tetrahymena:** disrupts in a few seconds. Enzymes which have been monitored include: succinate, lactate, B-hydroxy butyrate, glutamate and DPNH oxidases, DPNH-cytochrome C reductase and ribonuclease. Activity of DPNH oxidase was twice that of the best previous experiments.

**Thermoactinomyces:** disruption of hyphae. Homogenization of protein complex without denaturation.

**Thermophile negative:** good disruption within 2 minutes.

**Thermophilic bacillus:** Isocitrate lyase was extracted from a spore-forming bacillus similar to *Stearothermophilus*. A washed cell paste suspended in a phosphate buffer was sonified 1-2 minutes and the supernatant was used for enzyme experiments without further treatment. Extracts could be frozen and stored without loss of activity.

**Thiouric acid:** dissolved in a few seconds.

**Thymus cells:** complete disruption in 15 seconds.

**Tissue culture cells:** complete disruption in a few seconds. To avoid damage to free organelles and to obtain intact Lyososomes, use low power at short exposure.

**Toxin and antitoxin:** one example of many: Toxin preparations of whole cell lysate (WCL) of the Inaba serotype strain 569E of the classic biotype of cholera vibrio were grown on 3% Bacto peptane agar and harvested in distilled water at 18 hours. The unwashed suspensions were solubilized ultrasonically, clarified by centrifugation and the supernat freeze-dried for the titration of cholera toxin in the rabbit ileal loop.

**Toxoplasma gondii:** can be separated from white blood cells without injury.

**Transplantation antigens:** were extracted from spleen, thymus and lymph nodes.

**Trichomonas foetus:** Complete disruption in a few seconds

**Triolein:** Complete stable emulsion in 2 minutes.

**Trypanosomes:** concentrated 10 ml solution completely disrupts in 4 minutes.

**Uterus muscle:** a 1/5 gm, 3 cc solution completely disrupts in 3 minutes for coenzyme Q determination.

**Vaccines:** numerous advantages such as, more antigenic material released than usual and the production of vaccines not obtainable by classified methods.

**Various bacilli:** complete disruption in 3 minutes.

**Vibrio comma:** excellent disruption.

**Virus extraction:** excellent for experimental vaccines. Evidence of breakage of virus/antibody bonds. Virus can be extracted without damage at low power, or broken at high power.

**Vitamin E:** 30 seconds of ultrasonic treatment put material in solution with a resultant permanent suspension.

**W138 virus:** cell-free V-2 virus obtained in 30 seconds using 6 ml of Veronal buffer with W138 cells containing V-2 virus.

**Yeast:** complete disruption in 3-10 minutes. Complete disruption of 9 grams pressed yeast in 18 ml buffer in 8 minutes. Protein release, 52 mg/ml from an aged sample.

---

## Appendix B How to obtain Further Assistance

---

Customer Service, Technical Support, and Applications Assistance	
-----	B-1
Equipment Failure Support	B-1
Returning Equipment	B-1

### B.1 Customer Service, Technical Support, and Applications Assistance

Customer Service	800-732-9262
Technical Support	800-732-9262
Applications Assistance	203-796-0532

### B.2 Equipment Failure Support

203-796-0551  
203-796-0355  
203-796-0529

### B.3 Returning Equipment

Contact Customer Service 800-732-9262



---

## Appendix C Accessories

---

Micro Tip	- - - - -	C-1
Cup Horn	- - - - -	C-2
Flow-thru Horn	- - - - -	C-3
Rosette Cell	- - - - -	C-3
Continuous-Flow Attachment	- - - - -	C-4
Soundproof Box	- - - - -	C-4

Special disruptor horns, various horn tips and a variety of vessels for batch or continuous processing are available for use with Branson Sonifiers. Accessories include the following:

### C.1 Micro Tip

Particularly useful for processing small volumes, micro tips are available in two designs, tapered and stepped, to meet your application requirements.

The tapered micro tip attaches directly to a standard 1/2" tapped disruptor horn. The amplitude at the end of a tapered tip is three and a half times greater than that of the standard horn. The tapered tip is recommended for difficult applications such as spores, fungi, yeast, muscle, and connective tissue. Excellent results can be achieved on volumes ranging from 3 to 20 ml in a comparatively short period of time. The diameter of the tapered micro tips are 1/8" (3.2 mm), 3/16" (4.8mm) and 1/4" (6.4mm).

---

The stepped micro tip is a two-piece horn, consisting of a coupling section and a lower tip. Because the coupling section is attached directly to the converter, the standard disruptor horn must be removed prior to using the stepped micro tip. Recommended for use on extremely small volumes, the stepped tip can be used to treat volumes ranging from 0.5 to 20 ml. Applications for this tip include red and white blood cells, tissue culture cells, HeLa cells and the complete range of cells which have low to medium resistance to breakage.

To prevent foaming or aerosoling while processing small quantities with the tapered or stepped micro tips, the use of a conical shaped tube such as an eppendorf tube or a cut down centrifuge tube is recommended.



When using micro tips, a maximum Output Control Setting of “7” must not be exceeded. The micro tip will break if driven at higher amplitudes.

---

## C.2 Cup Horn

Cup Horns allow materials to be treated in small eppendorf style tubes or test tubes without immersing the ultrasonic horn or micro tip in the material, thereby providing completely sterile conditions. The Cup Horn is attached directly to the converter and the assembly is mounted upside down on the lab stand, or in our Sound Enclosure with the Cup Horn at the top. With chilled water in the Cup Horn, the tubes are suspended in the Cup with the contents of the tubes just below the water level. Ultrasonic energy is then conducted from the surface of the horn, through the water and tube walls, to the contents of the tube.

Some energy loss may be experienced when applying ultrasonics in this indirect way and processing may take longer than if the ultrasonic horn were immersed directly in the solution.

There are two types of Cup Horns, a high intensity unit that will accommodate a single test tube, and a larger unit for multiple test tubes. The high intensity Cup Horn has a concave bottom that focuses the ultrasonic energy on the bottom of the tube. The larger unit with a diameter of 2 or 3 inches allows the immersion of multiple test tubes. The larger Cup Horns have clear plastic walls, which permit easy viewing of the activity in the tubes during processing. Both types of Cup Horns



---

are designed to allow chilled water to circulate through the Cup Horn to prevent heating of the solution as a result of the ultrasonic activity. The Cup Horn is available with a water cooling device which allows water to flow through the cup, keeping the material cool.

---

**CAUTION**

The bottom of the test tubes should not be in contact with the surface of the ultrasonic horn, which could cause breakage.

---

## **C.3 Flow-thru Horn**

Designed for pharmaceutical research, the flow-thru horn has two inputs or orifices at the non-vibrating, nodal point of the horn. A pre-mixed substance is fed through one of the units while the horn is ultrasonically activated. Because two inputs are available, two different types of material can be treated simultaneously, for mixing or emulsifying. The processed solution exits at the tip of the horn. The horn may be used as a continuous-flow device to collect the solution in one large vessel. Or, by using a special switching, an instantaneous ON/OFF action permits multiple tubes or vials to be filled.

## **C.4 Rosette Cell**

The Rosette Cell, made of borosilicate glass, has a conical shape with three side arms, through which the solution is driven by the ultrasonic horn, thereby exposing the substance to ultrasonic energy repeatedly during circulation. When the Rosette Cell is immersed in a cooling bath, the enlarged glass surface area, plus circulation through the side arms, provide an efficient means of heat exchange.

The Cell is available in three sizes: 35-300 ml, 25-180 ml, and 8-25 ml.

---

## C.5 Continuous-Flow Attachment

This attachment, which is screwed on to the disruptor horn, permits continuous processing of low-viscosity materials at rates up to 38 liters per hour. Designed primarily for emulsifying, dispersing and homogenizing, the attachment will disrupt most cells, with the exception of the more difficult species. The materials being treated may be passed through the attachment more than once to obtain desired results. For cooling, a water jacket with input, output, and overflow connections is provided.

## C.6 Soundproof Box

Even though ultrasound is above the audible range of the human ear, mechanical noise occurs when liquids are treated ultrasonically. The soundproof box reduces this noise by 25 to 28 db. It is especially useful when the Sonifier is used for extended periods of time.

**Figure C.1** Soundproof Box



## Appendix D Accessories Parts List

Accessories Parts List - - - - -D-1

### D.1 Accessories Parts List

*Table D.1 Accessories Parts List*

ITEM	DESCRIPTION	BRANSON EDP No.
Disruptor Horns	1/2" dia. stepped, w/grad scale	101-147-036
	1/2" dia. stepped, tapped	101-147-037
	1/2" dia. stepped, solid	101-147-038
	3/8" dia. stepped, solid	101-147-039
	1/2" dia. exponential, tapped	101-147-040
	1/2" dia. exponential, solid	101-147-041
	1/2" dia. catenoidal, solid	101-147-042
	3/4" dia. stepped, solid	101-147-043
	1" dia. threaded body, solid	101-147-044

**Table D.1** Accessories Parts List

ITEM	DESCRIPTION	BRANSON EDP No.
	3/4" dia. solid, high gain	101-147-035
Cup Horns	Permit materials to be treated while isolated in small test tubes. Cups have transparent plastic bodies	
	2" diameter	101-147-047
	3" diameter	101-147-048
Cup Horn	High intensity with flow thru ports- with water jacket	101-147-046
Continuous Flow Attach- ment	Permits continuous processing of low-viscosity materials with rates up to 38 liters/hour. Designed primarily for emulsifying, dispersing and homogenizing, this attachment will disrupt most cells, with the exception of the more difficult types. Materials being treated may be passed through the attachment more than once to obtain the desired results. A water jacket, input, output and overflow connections are provided. For use with horns having outside threads	100-146-171
Sealed Atmo- sphere Treat- ment Chamber	Used for batch treatment of infectious materials. Input and output connections allow filling and emptying without breaking the airtight seal and permit processing with an inert gas. Stainless steel.	
	3 - 10ml	101-021-001
	6 - 15ml	101-021-002

**Table D.1** Accessories Parts List

ITEM	DESCRIPTION	BRANSON EDP No.
	20 - 50ml	101-021-003
Sealed Atmosphere Treatment Chamber	Same as above 101-021-001 series, but with cooling water jacket.	
	3 - 10ml	101-021-004
	6 - 15ml	101-021-005
	20 - 50ml	101-021-006
Wrenches	For use with Branson Cell Disruptors	
	Spanner	201-118-019
	Open-end, for 1/2" horn	201-118-010
Flat Tip	Replacement for 1/2" horn	101-148-013
Tapered Micro Tips	For processing small volumes. Attaches to standard tapped disruptor horn. Tip amplitude is 3 1/2 times greater than that of standard horn. Recommended for difficult applications, such as spores, fungi, yeast, muscle and connective tissue. Excellent results on volumes ranging from 3 - 20ml in a comparatively short time.	
	1/8" diameter	101-148-062
	3/16" diameter	101-148-069
	1/4" diameter	101-148-070

**Table D.1** Accessories Parts List

ITEM	DESCRIPTION	BRANSON EDP No.
Double-Step Micro Tip Assembly	<p>A two-piece horn consisting of a coupling section and a lower tip. The standard disruptor horn must be removed prior to using this tip. recommended for use on extremely small volumes (0.5 - 20ml). applications include red and white blood cells, tissue culture cells, Hela cells. Overall length is 9 1/8" with 1/8" dia. in the lower 2 1/8".</p>	
	<p><b>NOTICE</b> The double-step microtip is to be used only with coupler.</p>	
	Coupler Section Only	101-147-050
Micro Tip Section Only	101-148-063	
Stud	Replacement adaptor stud. (Horn to Converter.	100-098-249
Rosette Cooling Cell	<p>Borosilicate glass cell has conical shape with three arms to allow circulation of substance being processed. When the cell is immersed in a cooling bath, the enlarges glass surface areas, plus circulation through the arms provide and effective means of heat exchange.</p>	
	Model 25 8-25 ml	201-123-001
	Model 50 25-180ml	201-123-002

**Table D.1** Accessories Parts List

ITEM	DESCRIPTION	BRANSON EDP No.
	Model 250 35-300ml	201-123-003
Tissue Disruptor	Designed for disintegration of difficult tissues. Stainless steel construction. Cell bottom holds up to 6g of tissue. A water jacket is provided for cooling.	101-021-007
Soundproof Enclosure	Reduces mechanical noise generated during liquid processing to a normal level. Especially useful when using a cell disruptor for extended periods. 25 to 28 db cavitation noise reduction.	101-063-275
Glass Beads	For cell homogenization. Waterproof, 1 pound packages.	
	1/2 mm diameter	201-002-004
	25 micron diameter	201-002-003
	35 micron diameter	201-002-005
1/2 Wave Horn	Extends 1/2" dia. disruptor horn an additional 1/2 wavelength (apprx. 5") at a 1/2" diameter.	101-147-049

