

www.bradyeurope.com/labid

Laboratory Identification

Labels, printers & software for laboratories



Laboratory Identification

Labels, printers & software for the laboratory

TABLE OF CONTENT

Simplify Your Laboratory Identification 4

Laboratory Identification Labels

Choose your Application	6
Vial / Tube Labels	8
Vial Top Labels	13
Centrifuge / Microcentrifuge Labels	15
Cryo Tubes & Vials	18
Conical / Large Tube Labels	20
Slide Labels	25
Tissue Cassette Labels	26
Straw and Rod Labels	27
Well Plate Labels	28
Bottles / Flasks & Dishes	31
Bottle Tamper Seal Labels	33
General Lab ID	34

Label Printers, Label Attachment System and Barcode Scanners

Choose Your Printer	38
BMP™21-LAB Label Printer	40
BMP™51 Label Maker	41
BMP™71 Portable Label Printer	42
BBP™12 Label Printer	43
BBP™33 Label Printer	44
Brady IP™ Series Printer	45
BradyPrinter PR Plus Thermal Transfer Printer	46
BSP™31 Label Attachment System	47
Label Creation Software	48
Scanners for Laboratories	49

Miscellaneous Products

Hazardous Substance Identification	52
Sorbent Products	54
Pipemarkers	58
Safety Signs on Rolls	58

The Brady Advantage

When it comes to identification, safety and compliance, there's a clear advantage to working with Brady. We put our customers first in everything we do.

Our goal is to give you an unrivalled customer experience. We are relentlessly committed to performance and excellence - in our products, services and people.

Our products and solutions perform in ways that others simply can't match. Our people perform in ways that regularly exceed your expectations, and our focus and discipline work toward solid, long-term performance for our customers.

In short, Brady is the company you trust when performance matters most.

Learn more about the Brady Advantage at: www.bradyeurope.com



Simplify Your Laboratory Identification

Brady's laboratory identification products are designed to serve the world's biotechnology, agricultural, environmental and forensic researchers. Whether you work in pathology, histology, chromatography or other areas of science, Brady labelling solutions can help you maintain Good Laboratory Practice

Brady Sample Identification solutions:

- match existing vial, slide, and well plate sizes
- remain legible throughout processing and storage
- endure freezer storage, liquid nitrogen, autoclave, hot water baths and solvents including Xylene, DMSO and Ethanol
- allow bar coding for extensive information storage on even the tiniest sample
- integrate seamlessly with your Laboratory Information Management System (LIMS)

Hand-written versus printed labels

Did you ever had to postpone research because of unidentified samples, or because nobody was able to read anymore what was once written on the sample you need? Printed laboratory labels, engineered specifically to identify samples, help avoid sample loss and a lot of frustration.



Hand-Written Information

- Is difficult to read
- Smears when handled
- Has limited communication potential
- Fades over time when stored
- Is erased by chemicals

Brady Printed Laboratory Labels

- Are crisp, clear and readable
- Do not smear nor fade
- Can hold much information
- Have increased durability
- Resist chemicals

Lab-durable labels

Brady's special self-laminating or wrap around label protects your label's legend from extreme temperature, chemicals and solvents.

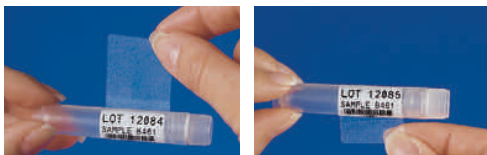

For best adhesion, we recommend that you do not touch the adhesive side of the label when wrapping it around your vial or tube.

- Printing is readable every time
- Clear portion wraps around and laminates the legend
- Provides window to view liquid level inside vial
- Low profile (extremely thin) label resists jamming in centrifuge or racks
- Labels withstand liquid nitrogen (-196°C), freezer (-80°C), autoclave (+121°C) and chemicals like Xylene

On-site Label Creation

Brady printers enable professionals to print highly specialised identification labels on-site and on demand. Partnered with customisable software and a specific application system for laboratories, adaptable to specific processes or data file formats, Brady printers support considerable time savings and flexibility in sample identification.

Every Brady identification label can be printed on-site using a Brady mobile, or benchtop printer. See page 38 for the full range of label printers.



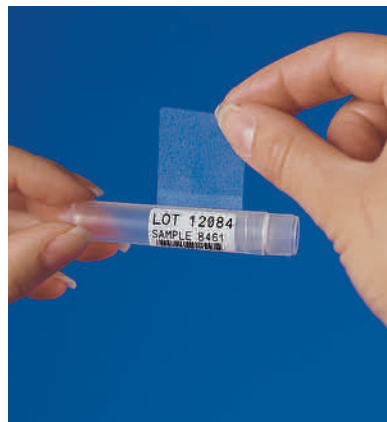

Laboratory Identification Labels

Extensive material knowledge combined with chemical expertise enables Brady to develop durable labels that perform throughout sample storage and processing.

Choose your Application.....	6
Vial / Tube Labels.....	8
Vial Top Labels.....	13
Centrifuge / Microcentrifuge Labels	15
Cryo Tubes & Vials	18
Conical / Large Tube Labels	20
Slide Labels.....	25
Tissue Cassette Labels	26
Straw and Rod Labels.....	27
Well Plate Labels	28
Bottles / Flasks & Dishes	31
Bottle Tamper Seal Labels.....	33
General Lab ID.....	34

Choose your Application



Vial/Tube



Conicals/bottles



Slide



Tissue cassette



Straw

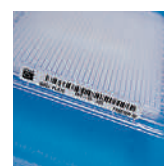

Well Plate



General Lab ID

Material	Printer Ribbon Series	Temp (°C) (Tested for 30 days)		APPLICATION						ENVIRONMENT			OTHER QUALITIES		
				Vial/Tube	Conical / Large Tubes	Slide	Tissue Cassette	Straw	Well Plate	General Lab ID	Freezer	Liquid Nitrogen	Autoclave (121°C)	Hot Water Bath (100°C)	Low-Profile (extremely thin)
FreezerBondz™ Polyester															
B-490	R4306	-196 °C	130 °C	✓	✓					✓	✓	✓	✓	✓	Retaining perfect integrity and legibility in liquid nitrogen, this ultra thin label avoids jamming in narrow racks and can be applied to already frozen surfaces with a small overlap.
B-492	R6400	-196 °C	130 °C	✓	✓					✓	✓	✓	✓	✓	Retaining perfect integrity and legibility in liquid nitrogen, this ultra resistant label, combined with the R6400 print ribbon, can resist a range of chemicals and can be applied to already frozen surfaces with a small overlap.
Nylon Cloth															
B-499	R4300; R6000; R6200B; R7950	-196 °C	90 °C	✓	✓					✓	✓	✓	✓	✓	Permanent adhesion; write-on capabilities. Temperature range increases to 121°C when used in autoclave process. Tested 3 cycles of 1 hour in 121°C at 15 psi for autoclave process.
Paper															
B-424	R4300; R7950	-80 °C	50 °C							✓	✓				Permanent adhesive; write-on capabilities; good contrast and smear resistance.
Polyester															
B-423	R6000; R4410	-70 °C	120 °C	✓						✓	✓	✓	✓	✓	Permanent acrylic adhesive; ideal for flat surfaces. Suitable to adhering to glass, but not polypropylene.
B-430	R6000	-80 °C	120 °C	✓						✓	✓	✓	✓	✓	Clear polyester with permanent acrylic based adhesive; withstands numerous solvents and can be applied to variable surfaces.
B-432	R6000	-40 °C	100 °C							✓	✓	✓	✓		Clear polyester with permanent acrylic based adhesive; withstands numerous solvents and can be applied to variable surfaces.
B-461	R4300, R7950	-196 °C	130 °C	✓	✓			✓		✓	✓	✓	✓	✓	Permanent adhesive; suitable for liquid nitrogen application if material is wrapped around itself, as in self-lamination; write-on capabilities. Temperature range increases to 121°C when used in autoclave process.
B-482	R6400	-80 °C	130 °C				✓			✓			✓		The B-482 label material, combined with Brady's R6400 ribbon, provides the durability and print quality that histology and anatomic pathology labs need for accurate, identifiable specimen labelling. Paraffin and solvent resistant.
B-488	R4300, R7950	-80 °C	120 °C	✓	✓					✓	✓	✓	✓		Permanent acrylic adhesive; ideal for flat surface; write-on capabilities; excellent solvent resistance and xylene resistance.
B-533	R6000	-70 °C	100 °C							✓	✓	✓	✓		Removable, ideal for flat surfaces. Suitable to adhering to glass, but not polypropylene.
B-8423	R6000	-80 °C	120 °C	✓						✓	✓	✓	✓		Permanent acrylic adhesive; semi-gloss finish; excellent for bar code labels.

Choose your Application



Vial/Tube



Conicals/bottles



Slide



Tissue cassette



Straw

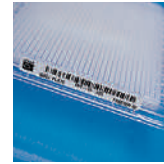

Well Plate



General Lab ID

Material	Printer Ribbon Series	Temp (°C) (Tested for 30 days)		APPLICATION							ENVIRONMENT			OTHER QUALITIES
				Vial/Tube	Conical / Large Tubes	Slide	Tissue Cassette	Straw	Well Plate	General Lab ID	Freezer	Liquid Nitrogen	Autoclave (121°C)	
Polypropylene														
B-425	R6400	-70 °C	100 °C	✓	✓					✓	✓	✓		Excellent solvent resistance.
B-449	R7961	-80 °C	90 °C	✓	✓						✓	✓	✓	Ideal for temporary labelling applications. Removable from flat surfaces; write-on capabilities; Tested 3 cycles of 1 hour in 121°C at 15 psi for autoclave process.
B-7425	R4300	-70 °C	80 °C	✓						✓	✓	✓	✓	For freezer or liquid nitrogen applications, B-7425 must be applied prior to being frozen.
StainerBondz™ Polyester														
B-481	R6400	-80 °C	130 °C			✓				✓	✓		✓	White polyester will remain resistant when exposed to xylene and other chemicals that are commonly used in the slide staining process.
Tamper-resistant Vinyl														
B-351	R6200	-80 °C	120 °C							✓	✓	✓		Tamper-evident with a permanent acrylic adhesive; fractures easily to prevent removal.
B-7351	R6210	-40 °C	100 °C							✓	✓	✓		Tamper-evident with a permanent acrylic adhesive; fractures easily to prevent removal.
Vinyl														
B-427	R4300	-80 °C	70 °C	✓	✓		✓				✓	✓		Permanent acrylic adhesive; self-laminating; write-on capabilities; suitable for liquid nitrogen application and can be used to identify a frozen vial if label material is wrapped around itself, as in self-lamination. Temperature range goes to -196°C if material is wrapped around vial and overlaps itself.
B-595	R6000; R4400; R6900	-40 °C	82 °C							✓	✓	✓		Available in White, Red, Yellow, Green, Blue, Orange, Black and Clear.
Vinyl Cloth														
B-498	R4300	-40 °C	80 °C	✓	✓	✓				✓	✓	✓		Removable from flat surfaces; write-on capabilities. Available in White.

i Part number explanation

Most Brady references for printable labels follow the same three-part format: The first code indicates the technology, the second part is a number indicating the label size (where applicable) and the third part indicates the Brady material (where applicable).

M71-73-461

BMP71
Technology

Label size
code

Material
(B-number)

Vial / Tube Labels



VIAL / TUBE LABELS

Brady's vial and test tube labels are designed to withstand extreme laboratory solvents like Xylene, Ethanol, Alcohol and DMSO, ensuring that the specimen identification is always legible - and will not smear, fade or fall off.

- F** Freezer environment
- N** Liquid nitrogen environment
- A** Autoclave environment
- H** Hot water bath (100°C)
- S** Self-laminating label
- L** Low-profile (extremely thin) label
- R** Removable

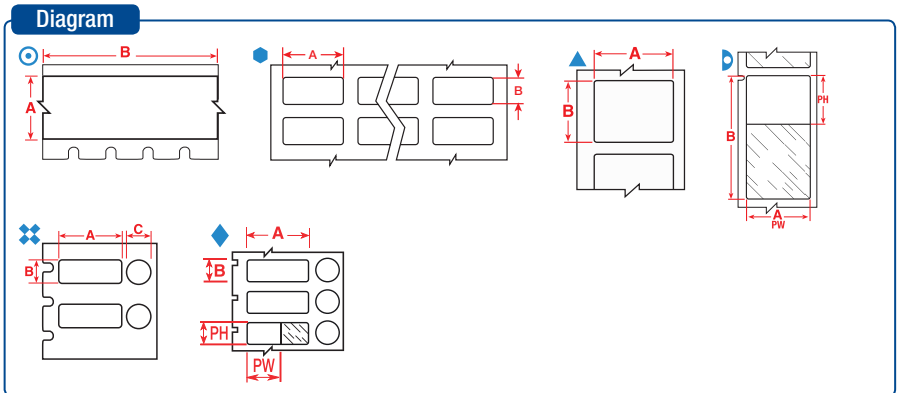

Labels are shown per vial / tube size and in order of label width.

The background colours in the Order Reference column represent the material colour.

See page 38 for Brady's range of label printers.

Diagram	Material	Special Properties	Label Width A (mm)	Label Height B (mm)	Label Length B (m)	Diameter C (mm)	Printable Area Width PW (mm)	Printable Area Height PH (mm)	Order Reference	Printer Compatibility	Printer Ribbon Series	Labels/Package	Labels per Row
0.5 ml													
⊙	B-423	F A H	6.35	-	6.40	-	-	-	M21-250-423	BMP21-LAB	-	1	1
0.5 - 0.7 ml													
▷	B-461	F N A H S L	9.53	45.72	-	-	9.53	19.05	M71-73-461	BMP71	M71-R6200	250	1
⬢	B-490	F N H L	12.70	19.05	-	-	-	-	B33-68-490	BBP33	B30-R4300	2500	4
⬢	B-498	F R	12.70	19.05	-	-	-	-	B33-68-498	BBP33	B30-R6200	5000	4
⬢	B-499	F N A	12.70	19.05	-	-	-	-	B33-68-499	BBP33	B30-R6000HF	1500	4
⬢	B-498	F R	12.70	19.05	-	-	-	-	THT-68-498-10	BBP12, BP-PR+, IP	R4300, R7950	10000	4
⬢	B-499	F N A	12.70	19.05	-	-	-	-	THT-68-499-10	BBP12, BP-PR+, IP	R4900	10000	4
▲	B-499	F N A	12.70	25.40	-	-	-	-	B33-620-499	BBP33	B30-R6000HF	1000	1
▲	B-499	F N A	12.70	25.40	-	-	-	-	BPT-620-499	BBP12, BP-PR+	R7950	1000	1
▷	B-461	F N A H S L	12.70	55.88	-	-	12.70	19.05	B33-127-461	BBP33	B30-R4300	1500	3
▷	B-427	F N S	12.70	55.88	-	-	12.70	19.05	THT-127-427-3*	BBP12, BP-PR+, IP	R4300, R7950	3000	1
▷	B-461	F N A H S L	12.70	55.88	-	-	12.70	19.05	THT-127-461-3*	BBP12, BP-PR+, IP	R4300, R7950	3000	1
▷	B-461	F N A H S L	12.70	55.88	-	-	12.70	19.05	THT-127-461-1.5-SC*	BBP12, BP-PR+	R7950	1500	1
▲	B-498	F R	19.05	12.70	-	-	-	-	BM71-11-498	BMP71	M71-R6200	5000	1
▲	B-498	F R	19.05	12.70	-	-	-	-	M71-11-498	BMP71	M71-R6200	500	1
⬢	B-492	F N H L	25.40	9.53	-	-	-	-	B33-152-492	BBP33	B30-R6400	2500	2
⬢	B-499	F N A	25.40	9.53	-	-	-	-	B33-152-499	BBP33	B30-R6000HF	1500	2
▲	B-492	F N H L	25.40	9.53	-	-	-	-	M71-16-492	BMP71	M71-R6400	500	1
⊗	B-499	F A	25.40	9.53	-	9.53	-	-	M71-98-499	BMP71	M71-R4300	500	1
⬢	B-492	F N H L	25.40	9.53	-	-	-	-	THT-152-492-3	BBP12, BP-PR+, IP	R6400	3000	2
⬢	B-499	F N A	25.40	9.53	-	-	-	-	THT-152-499-3	BBP12, BP-PR+, IP	R4900	3000	2
▲	B-492	F N H L	25.40	9.53	-	-	-	-	THT-152-492-2.5-SC	BBP12, BP-PR+	R6400	2500	2
⬢	B-499	F N A	25.40	9.53	-	-	-	-	THT-152-499-1.5-SC	BBP12, BP-PR+	R7950	1500	2
◆	B-461	F A H S L	25.40	9.53	-	9.53	20.00	9.53	BPT-606-461	BBP12, BP-PR+	R7950	1000	1
⬢	B-425	F	25.40	9.98	-	-	-	-	THT-30-425-10	BBP12, BP-PR+, IP	R6400	10000	3

*Label is rotated 90° on liner.

>>

Diagram

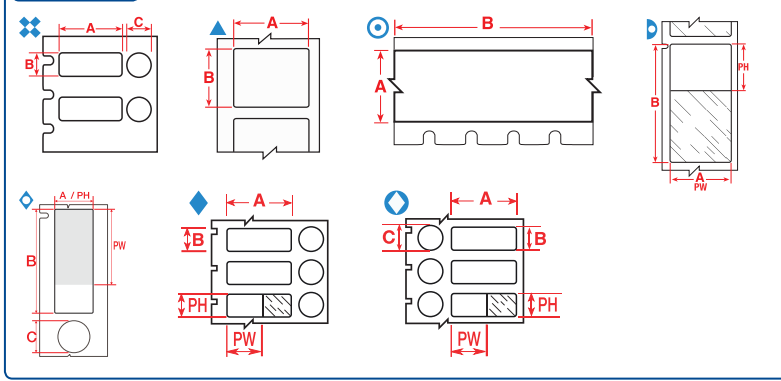

Labels are shown per vial / tube size and in order of label width.

The background colours in the Order Reference column represent the material colour.

See page 38 for Brady's range of label printers.

Diagram	Material	Special Properties	Label Width A (mm)	Label Height B (mm)	Label Length B (m)	Diameter C (mm)	Printable Area Width PW (mm)	Printable Area Height PH (mm)	Order Reference	Printer Compatibility	Printer Ribbon Series	Labels/Package	Labels per Row
0.5 - 8.0 ml													
❖	B-492	F H L	25.40	9.53	-	9.53	-	-	THT-249-492-1.5-SC	BBP12, BP-PR+	R6400	1500	1
❖	B-499	F A	25.40	9.53	-	9.53	-	-	THT-249-499-1.5-SC	BBP12, BP-PR+	R7950	1500	1
❖	B-492	F H L	25.40	12.70	-	11.18	-	-	THT-251-492-1.5-SC	BBP12, BP-PR+	R6400	1500	1
❖	B-492	F H L	25.40	12.70	-	9.53	-	-	THT-250-492-1.5-SC	BBP12, BP-PR+	R6400	1500	1
0.6 ml													
⊙	B-499	F N A	9.53	-	4.88	-	-	-	M21-375-499	BMP21-LAB	-	1	1
⊙	B-499	F N A	9.53	-	4.88	-	-	-	MC-375-499	BMP51, BMP53	-	1	1
⊙	B-7425	F N A H	9.53	-	6.40	-	-	-	M21-375-7425	BMP21-LAB	-	1	1
⊙	B-461	F N A H S L	9.53	-	6.40	-	9.53	-	M21-375-461-AW**	BMP21-LAB	-	1	1
▲	B-490	F N H L	22.86	12.70	-	-	-	-	B33-125-490	BBP33	B30-R4300	1650	1
▲	B-499	F N A	22.86	12.70	-	-	-	-	B33-125-499	BBP33	B30-R6000HF	1500	1
▲	B-499	F N A	22.86	12.70	-	-	-	-	M71-84-499	BMP71	M71-R4300	500	1
▲	B-499	F N A	22.86	12.70	-	-	-	-	THT-125-499-3	BBP12, BP-PR+, IP	R4900	3000	1
▲	B-499	F N A	22.86	12.70	-	-	-	-	THT-125-499-1.5-SC	BBP12, BP-PR+	R7950	1500	1
1.0 - 2.0 ml													
▷	B-461	F N A H S L	15.00	40.00	-	-	15.00	30.00	BPTLAB-21-461-2.5	BBP12, BP-PR+	R7950	2500	1
▷	B-461	F N A H S L	15.24	38.10	-	-	15.24	33.00	BPT-628-461*	BBP12, BP-PR+	R7950	2500	2
▷	B-461	F N A H S L	15.24	38.10	-	-	15.24	33.00	M71-100-461	BMP71	M71-R6200	500	1
▷	B-461	F N A H S L	15.24	38.10	-	-	15.24	33.03	B33-628-461*	BBP33	B30-R4300	2500	2
◇	B-461	F A H S L	15.24	41.28	-	12.70	15.24	30.00	M71-116-461	BMP71	M71-R6200	150	1
▷	B-461	F N A H S L	15.24	66.68	-	-	15.24	25.40	B33-612-461	BBP33	B30-R4300	1500	3
▷	B-461	F N A H S L	15.24	66.68	-	-	15.24	25.40	BPT-612-461	BBP12, BP-PR+	R7950	1500	3
❖	B-492	F H L	25.40	9.53	-	9.53	-	-	B33-163-492	BBP33	B30-R6400	1500	1
❖	B-499	F A	25.40	9.53	-	9.53	-	-	B33-163-499	BBP33	B30-R6000HF	1500	1
❖	B-492	F H L	25.40	9.53	-	9.53	-	-	THT-163-492-3	BBP12, BP-PR+, IP	R6400	3000	1
❖	B-499	F A	25.40	9.53	-	9.53	-	-	THT-163-499-3	BBP12, BP-PR+, IP	R4900	3000	1
❖	B-492	F H L	25.40	12.70	-	9.53	-	-	B33-181-492	BBP33	B30-R6400	1500	1
❖	B-492	F H L	25.40	12.70	-	11.18	-	-	B33-182-492	BBP33	B30-R6400	1500	1
❖	B-492	F H L	25.40	12.70	-	9.53	-	-	M71-118-492	BMP71	M71-R6400	500	1
❖	B-492	F H L	25.40	12.70	-	11.18	-	-	THT-182-492-3	BBP12, BP-PR+, IP	R6400	3000	1
❖	B-492	F H L	25.40	12.70	-	9.53	-	-	THT-181-492-3	BBP12, BP-PR+, IP	R6400	3000	1
▷	B-461	F N A H S L	25.40	44.45	-	-	25.40	25.40	B33-183-461	BBP33	B30-R4300	2000	1
▷	B-461	F N A H S L	25.40	44.45	-	-	25.40	25.40	M71-106-461	BMP71	M71-R6200	250	1
▷	B-461	F N A H S L	25.40	44.45	-	-	25.40	25.40	THT-183-461-1	BBP12, BP-PR+, IP	R4300, R7950	1000	1
◇	B-461	F A H S L	40.00	15.00	-	9.00	30.00	15.00	BPTLAB-20-461-2.5	BBP12, BP-PR+	R7950	2500	1
◇	B-461	F A H S L	40.00	15.00	-	9.53	30.00	15.00	M71-101-461	BMP71	M71-R6200	250	1
❖	B-499	F A	41.28	15.24	-	12.70	-	-	BPT-608-499	BBP12, BP-PR+	R7950	1000	1
◇	B-461	F A H S L	41.28	15.24	-	12.70	30.00	15.24	B33-608-461	BBP33	B30-R4300	1000	1
◇	B-461	F A H S L	41.28	15.24	-	12.70	30.00	15.24	BPT-608-461	BBP12, BP-PR+	R7950	1000	1

*Label is rotated 90° on liner.

**AW = All White / no transparent area.

>>>

Vial / Tube Labels

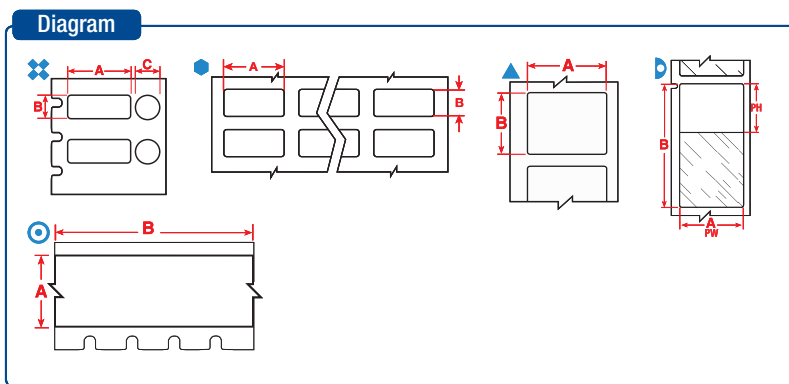

Labels are shown per vial / tube size and in order of label width.

The background colours in the Order Reference column represent the material colour.

See page 38 for Brady's range of label printers.

Diagram	Material	Special Properties	Label Width A (mm)	Label Height B (mm)	Label Length B (m)	Diameter C (mm)	Printable Area Width PW (mm)	Printable Area Height PH (mm)	Order Reference	Printer Compatibility	Printer Ribbon Series	Labels/Package	Labels per Row
1.0 - 8.0 ml													
▷	B-461	FNAHSL	15.24	41.28	-	-	15.24	25.40	M71-76-461	BMP71	M71-R6200	500	1
▷	B-461	FNAHSL	15.24	66.68	-	-	15.24	25.40	B33-153-461*	BBP33	B30-R4300	1500	1
▷	B-461	FNAHSL	15.24	66.68	-	-	15.24	25.40	M71-86-461	BMP71	M71-R6200	100	1
●	B-498	F	19.05	23.80	-	-	-	-	B33-91-498	BBP33	B30-R6200	2500	4
●	B-498	F	19.05	23.80	-	-	-	-	THT-91-498-5	BBP12, BP-PR+, IP	R4300, R7950	5000	4
⊗	B-490	FHL	22.86	12.70	-	12.70	-	-	B33-126-490	BBP33	B30-R4300	2500	1
⊗	B-499	FA	22.86	12.70	-	12.70	-	-	M71-126-499	BMP71	M71-R4300	500	1
⊗	B-499	FA	22.86	12.70	-	12.70	-	-	THT-126-499-3	BBP12, BP-PR+, IP	R4900	3000	1
▲	B-498	F	25.40	19.05	-	-	-	-	B33-88-498	BBP33	B30-R6200	2500	2
▲	B-498	F	25.40	19.05	-	-	-	-	BM71-18-498	BMP71	M71-R6200	2500	1
▲	B-498	F	25.40	19.05	-	-	-	-	M-48-498	BMP51, BMP53	-	180	1
▲	B-498	F	25.40	19.05	-	-	-	-	M71-18-498	BMP71	M71-R6200	250	1
▲	B-499	FNA	25.40	19.05	-	-	-	-	M71-18-499	BMP71	M71-R4300	250	1
●	B-492	FNHSL	25.40	19.05	-	-	-	-	THT-88-492-5	BBP12, BP-PR+, IP	R6400	5000	2
●	B-498	F	25.40	19.05	-	-	-	-	THT-88-498-5	BBP12, BP-PR+, IP	R4300, R7950	5000	2
▲	B-492	FNHSL	25.40	19.05	-	-	-	-	THT-88-492-2.5-SC	BBP12, BP-PR+	R6400	2500	2
▷	B-461	FNAHSL	25.40	66.68	-	-	25.40	25.40	M71-115-461	BMP71	M71-R6200	100	1
▷	B-427	FNS	25.40	66.68	-	-	25.40	25.40	THT-131-427-3*	BBP12, BP-PR+, IP	R4300, R7950	3000	1
▷	B-461	FNAHSL	25.40	66.68	-	-	25.40	25.40	THT-131-461-3*	BBP12, BP-PR+, IP	R4300, R7950	3000	1
▷	B-461	FNAHSL	25.40	66.68	-	-	25.40	25.40	THT-131-461-1.5-SC*	BBP12, BP-PR+	R7950	1500	1
▲	B-490	FNHSL	41.28	15.24	-	-	-	-	B33-155-490	BBP33	B30-R4300	1500	1
▲	B-492	FNHSL	41.28	15.24	-	-	-	-	B33-155-492	BBP33	R6400	1500	1
⊗	B-492	FHL	41.28	15.24	-	9.53	-	-	B33-190-492	BBP33	R6400	1500	1
▲	B-490	FNHSL	41.28	15.24	-	-	-	-	M71-76-490	BMP71	M71-R4300	500	1
⊗	B-492	FHL	41.28	15.24	-	9.53	-	-	THT-190-492-3	BBP12, BP-PR+, IP	R6400	3000	1
▲	B-490	FNHSL	41.28	15.24	-	-	-	-	THT-155-490-3	BBP12, BP-PR+, IP	R4300, R7950	3000	1
▲	B-492	FNHSL	41.28	15.24	-	-	-	-	THT-155-492-3	BBP12, BP-PR+, IP	R6400	3000	1
▲	B-490	FNHSL	41.28	15.24	-	-	-	-	THT-155-490-1.5-SC	BBP12, BP-PR+	R7950	1500	1
▲	B-492	FNHSL	44.45	25.40	-	-	-	-	M-125-492	BMP51, BMP53	-	180	1
▲	B-490	FNHSL	48.26	25.40	-	-	-	-	B33-156-490	BBP33	B30-R4300	1500	1
▲	B-492	FNHSL	48.26	25.40	-	-	-	-	B33-156-492	BBP33	B30-R6400	1500	1
▲	B-492	FNHSL	48.26	25.40	-	-	-	-	M71-78-492	BMP71	M71-R6400	250	1
▲	B-490	FNHSL	48.26	25.40	-	-	-	-	THT-156-490-3	BBP12, BP-PR+, IP	R4300, R7950	3000	1
▲	B-492	FNHSL	48.26	25.40	-	-	-	-	THT-156-492-3	BBP12, BP-PR+, IP	R6400	3000	1
▲	B-490	FNHSL	48.26	25.40	-	-	-	-	THT-156-490-1.5-SC	BBP12, BP-PR+	R7950	1500	1
▲	B-492	FNHSL	48.26	25.40	-	-	-	-	THT-156-492-1.5-SC	BBP12, BP-PR+	R6400	1500	1
▷	B-427	FNS	66.68	25.40	-	-	25.40	25.40	B33-131-427	BBP33	B30-R4300	1500	1
1.5 ml													
○	B-499	FNA	12.70	-	4.88	-	-	-	M21-500-499	BMP21-LAB	-	1	1
○	B-499	FNA	12.70	-	4.88	-	-	-	MC-500-499	BMP51, BMP53	-	1	1
○	B-7425	FNAH	12.70	-	6.40	-	-	-	M21-500-7425	BMP21-LAB	-	1	1
○	B-461	FNAHSL	12.70	-	6.40	-	12.70	-	M21-500-461-AW**	BMP21-LAB	-	1	1
○	B-499	FNA	12.70	-	9.10	-	-	-	M71C-500-499	BMP71	M71-R4300	1	1

*Label is rotated 90° on liner. **AW = All White / no transparent area.

>>>

Diagram

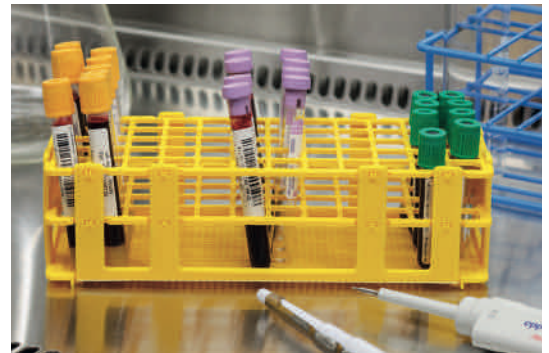
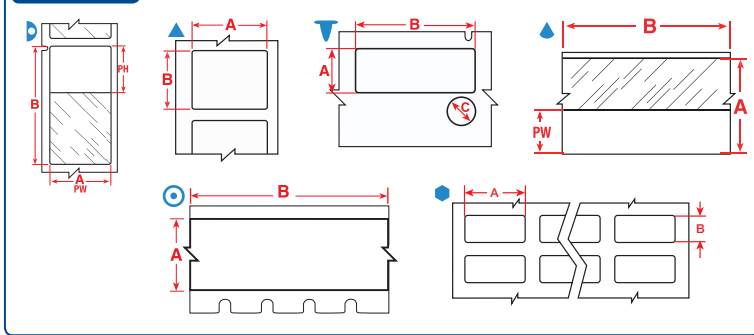

Labels are shown per vial / tube size and in order of label width.

The background colours in the Order Reference column represent the material colour.

See page 38 for Brady's range of label printers.

Diagram	Material	Special Properties	Label Width A (mm)	Label Height B (mm)	Label Length C (m)	Diameter D (mm)	Printable Area Width PW (mm)	Printable Area Height PH (mm)	Order Reference	Printer Compatibility	Printer Ribbon Series	Labels/Package	Labels per Row
1.5 - 2.0 ml													
▶	B-461	FNAHSL	15.24	41.28	-	-	15.24	25.40	B33-133-461	BBP33	B30-R4300	1500	3
▶	B-461	FNAHSL	15.24	41.28	-	-	15.24	25.40	THT-133-461-3*	BBP12, BP-PR+, IP	R4300, R7950	3000	1
▶	B-461	FNAHSL	15.24	41.28	-	-	15.24	25.40	THT-133-461-1.5-SC*	BBP12, BP-PR+	R7950	1500	1
▶	B-461	FNAHSL	15.24	66.68	-	-	15.24	25.40	THT-153-461-3*	BBP12, BP-PR+, IP	R4300, R7950	3000	1
▶	B-461	FNAHSL	15.24	66.68	-	-	15.24	25.40	THT-153-461-1.5-SC*	BBP12, BP-PR+	R7950	1500	1
▲	B-492	FNHL	25.40	12.70	-	-	-	-	B33-59-492	BBP33	B30-R6400	2500	1
▲	B-492	FNHL	25.40	12.70	-	-	-	-	THT-59-492-10	BBP12, BP-PR+, IP	R6400	10000	1
▲	B-492	FNHL	25.40	12.70	-	-	-	-	THT-59-492-2.5-SC	BBP12, BP-PR+	R6400	2500	1
▼	B-492	FHL	41.28	15.24	-	9.53	-	-	M-95-492	BMP51, BMP53	-	200	1
▲	B-492	FNHL	41.91	12.70	-	-	-	-	M-124-492	BMP51, BMP53	-	180	1
2.0 - 4.0 ml													
▶	B-461	FNAHSL	15.24	48.26	-	-	15.24	40.00	B33-638-461*	BBP33	B30-R4300	2000	1
▶	B-461	FNAHSL	15.24	48.26	-	-	15.24	40.00	BPT-638-461*	BBP12, BP-PR+	R7950	2000	1
▶	B-461	FNAHSL	15.24	48.26	-	-	15.24	40.00	M71-119-461	BMP71	M71-R6200	500	1
2.0 - 50.0 ml													
▲	B-427	FN S	19.05	-	4.30	-	9.53	-	M21-750-427	BMP21-LAB	-	1	-
○	B-499	FNA	19.05	-	4.88	-	-	-	M21-750-499	BMP21-LAB	-	1	1
○	B-499	FNA	19.05	-	4.88	-	-	-	MC-750-499	BMP51, BMP53	-	1	1
○	B-7425	FNAH	19.05	-	6.40	-	-	-	M21-750-7425	BMP21-LAB	-	1	1
○	B-461	FNAHSL	19.05	-	6.40	-	19.05	-	M21-750-461-AW**	BMP21-LAB	-	1	1
▲	B-427	FN S	19.05	-	7.62	-	9.53	-	MC-750-427	BMP51, BMP53	-	1	1
○	B-499	FNA	25.40	-	4.88	-	-	-	MC-1000-499	BMP51, BMP53	-	1	1
○	B-499	FNA	25.40	-	9.10	-	-	-	M71C-1000-499	BMP71	M71-R4300	1	1
4.0 - 8.0 ml													
●	B-499	FNA	25.40	66.68	-	-	-	-	B33-625-499	BBP33	B30-R6000HF	1500	3
●	B-499	FNA	25.40	66.68	-	-	-	-	BPT-625-499	BBP12, BP-PR+	R7950	1500	3
4.0 - 50.0 ml													
▶	B-461	FNAHSL	34.93	45.72	-	-	34.93	40.00	B33-632-461*	BBP33	B30-R4300	1500	1
▶	B-461	FNAHSL	34.93	45.72	-	-	34.93	40.00	BPT-632-461*	BBP12, BP-PR+	R7950	2000	1
5.0 - 50.0 ml													
○	B-499	FNA	48.26	-	9.10	-	-	-	M71C-1900-499	BMP71	M71-R4300	1	1
12.0 - 24.0 ml													
●	B-498	F R	12.70	36.50	-	-	-	-	B33-87-498	BBP33	B30-R6200	2500	6
●	B-498	F R	12.70	36.50	-	-	-	-	THT-87-498-5	BBP12, BP-PR+, IP	R4300, R7950	5000	6
12.0 - 50.0 ml													
▶	B-461	FNAHSL	25.40	133.35	-	-	25.40	38.10	B33-139-461	BBP33	B30-R4300	650	2
▶	B-461	FNAHSL	25.40	133.35	-	-	25.40	38.10	THT-139-461-2	BBP12, BP-PR+, IP	R4300, R7950	2000	2
14.0 - 15.0 ml													
▲	B-490	FNHL	55.88	38.10	-	-	-	-	THT-157-490-3	BBP12, BP-PR+, IP	R4300, R7950	3000	1
▲	B-490	FNHL	55.88	38.10	-	-	-	-	THT-157-490-1.5-SC	BBP12, BP-PR+	R7950	1500	1

*Label is rotated 90° on liner. **AW = All White / no transparent area.

>>

Vial / Tube Labels

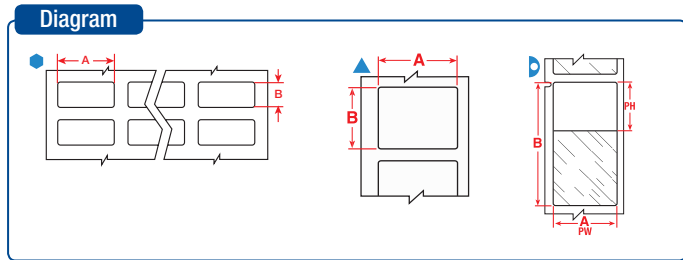

Labels are shown per vial / tube size and in order of label width.

The background colours in the Order Reference column represent the material colour.

See page 38 for Brady's range of label printers.

Diagram	Material	Special Properties	Label Width A (mm)	Label Height B (mm)	Label Length B (m)	Diameter C (mm)	Printable Area Width PW (mm)	Printable Area Height PH (mm)	Order Reference	Printer Compatibility	Printer Ribbon Series	Labels/Package	Labels per Row
15.0 - 50.0 ml													
⬡	B-499	FNA	12.70	25.40	-	-	-	-	B33-611-499	BBP33	B30-R6000HF	3000	3
⬡	B-498	F R	12.70	25.40	-	-	-	-	BPT-611-498	BBP12, BP-PR+	R7950	3000	3
⬡	B-499	FNA	12.70	25.40	-	-	-	-	BPT-611-499	BBP12, BP-PR+	R7950	3000	3
⬡	B-499	FNA	25.40	12.40	-	-	-	-	B33-659-499	BBP33	B30-R6000HF	1000	1
⬡	B-498	F R	25.40	12.40	-	-	-	-	BPT-659-498	BBP12, BP-PR+	R7950	1000	1
⬡	B-499	FNA	25.40	12.40	-	-	-	-	BPT-659-499	BBP12, BP-PR+	R7950	1000	1
⬡	B-499	FNA	25.40	36.50	-	-	-	-	B33-621-499	BBP33	B30-R6000HF	3000	3
⬡	B-498	F R	25.40	36.50	-	-	-	-	B33-89-498	BBP33	B30-R6200	2300	3
⬡	B-499	FNA	25.40	36.50	-	-	-	-	BPT-621-499	BBP12, BP-PR+	R7950	3000	3
⬡	B-461	FNAHSL	25.40	66.68	-	-	25.40	25.40	B33-276-461	BBP33	B30-R4300	1500	2
⬡	B-461	FNAHSL	38.10	88.90	-	-	38.10	31.75	B33-134-461*	BBP33	B30-R4300	1000	1
⬡	B-461	FNAHSL	38.10	88.90	-	-	38.10	31.75	THT-134-461-3*	BBP12, BP-PR+, IP	R4300, R7950	3000	1
50.0 ml													
⬡	B-492	FNHL	22.86	25.40	-	-	-	-	B33-180-492	BBP33	B30-R6400	1500	1
⬡	B-492	FNHL	22.86	25.40	-	-	-	-	THT-180-492-3	BBP12, BP-PR+, IP	R6400	3000	1
⬡	B-425	F	25.40	12.70	-	-	-	-	B33-5-425	BBP33	B30-R4300	5000	3
⬡	B-498	F R	25.40	12.70	-	-	-	-	B33-5-498	BBP33	B30-R6200	5000	3
⬡	B-425	F	25.40	12.70	-	-	-	-	THT-5-425-10	BBP12, BP-PR+, IP	R6400	10000	3
⬡	B-492	FNHL	25.40	25.40	-	-	-	-	B33-179-492	BBP33	B30-R6400	1900	1
⬡	B-492	FNHL	25.40	25.40	-	-	-	-	THT-179-492-3	BBP12, BP-PR+, IP	R6400	3000	1
⬡	B-492	FNHL	25.40	25.40	-	-	-	-	THT-179-492-2.5-SC	BBP12, BP-PR+	R6400	2500	1
⬡	B-490	FNHL	50.80	6.35	-	-	-	-	B33-151-490	BBP33	B30-R4300	2500	1
50.0 ml													
⬡	B-499	FNA	25.40	63.50	-	-	-	-	M71-21-499	BMP71	M71-R4300	100	1

*Label is rotated 90° on liner.



Vial and Tube ID

“Brady helps the world’s largest HIV research network develop more efficient, more accurate laboratory labelling protocols.

Adult Clinical Trials Group



VIAL TOP LABELS

Save time by using the Vial and Vial top combination labels - print your information in one go.

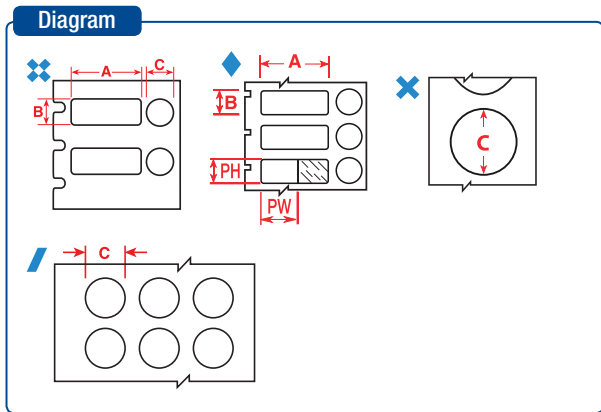

- F** Freezer environment
- A** Autoclave environment
- H** Hot water bath (100°C)
- S** Self-laminating label
- L** Low-profile (extremely thin) label
- R** Removable

Labels are shown per vial / tube size and in order of label width.

The background colours in the Order Reference column represent the material colour.

See page 38 for Brady's range of label printers.

Diagram	Material	Special Properties	Label Width A (mm)	Label Height B (mm)	Diameter C (mm)	Printable Area Width PW (mm)	Printable Area Height PH (mm)	Order Reference	Printer Compatibility	Printer Ribbon Series	Labels/Package	Labels per Row
0.5 - 0.7 ml												
❖	B-499	F A	25.40	9.53	9.53	-	-	M71-98-499	BMP71	M71-R4300	500	1
◆	B-461	F A H S L	25.40	9.53	9.53	20.00	9.53	B33-606-461	BBP33	B30-R4300	1000	1
◆	B-461	F A H S L	25.40	9.53	9.53	20.00	9.53	BPT-606-461	BBP12, BP-PR+	R7950	1000	1
0.5 - 1.5 ml												
✕	B-492	F H L	-	-	9.53	-	-	M-82-492	BMP51, BMP53	-	240	1
✕	B-499	F A	-	-	9.53	-	-	M-82-499	BMP51, BMP53	-	240	1
✕	B-499	F A	-	-	9.53	-	-	M-82-499-OR-BK	BMP51, BMP53	-	240	1
✕	B-499	F A	-	-	9.53	-	-	M-82-499-RD-BK	BMP51, BMP53	-	240	1
✕	B-499	F A	-	-	9.53	-	-	M-82-499-YL-BK	BMP51, BMP53	-	240	1
0.5 - 8.0 ml												
❖	B-492	F H L	25.40	9.53	9.53	-	-	THT-249-492-1.5-SC	BBP12, BP-PR+	R6400	1500	1
❖	B-499	F A	25.40	9.53	9.53	-	-	THT-249-499-1.5-SC	BBP12, BP-PR+	R7950	1500	1
❖	B-492	F H L	25.40	12.70	9.53	-	-	THT-250-492-1.5-SC	BBP12, BP-PR+	R6400	1500	1
❖	B-492	F H L	25.40	12.70	11.18	-	-	THT-251-492-1.5-SC	BBP12, BP-PR+	R6400	1500	1
0.6 - 1.5 ml												
/	B-492	F H L	-	-	9.53	-	-	B33-143-492	BBP33	B30-R6400	1500	4
/	B-499	F A	-	-	9.53	-	-	B33-143-499	BBP33	B30-R6000HF	1500	4
/	B-499	F A	-	-	9.53	-	-	M71-82-499	BMP71	M71-R4300	500	1
/	B-492	F H L	-	-	9.53	-	-	THT-143-492-3	BBP12, BP-PR+, IP	R6400	3000	4
/	B-499	F A	-	-	9.53	-	-	THT-143-499-3	BBP12, BP-PR+, IP	R4900	3000	4
/	B-492	F H L	-	-	9.53	-	-	THT-143-492-1.5-SC	BBP12, BP-PR+	R6400	1500	4
0.6 - 50.0 ml												
/	B-499	F A	-	-	9.53	-	-	B33-602-499	BBP33	B30-R6000HF	3000	3
/	B-461	F A H S L	-	-	9.53	-	-	B33-602-461AW**	BBP33	B30-R4300	3000	3
/	B-499	F A	-	-	9.53	-	-	B33-602-499YL	BBP33	B30-R6000HF	3000	3
/	B-499	F A	-	-	9.53	-	-	BPT-602-499	BBP12, BP-PR+	R7950	3000	3
✕	B-461	F A H S L	-	-	9.53	-	-	BPT-602-461AW**	BBP12, BP-PR+	R7950	3000	3
/	B-499	F A	-	-	9.53	-	-	BPT-602-499YL	BBP12, BP-PR+	R7950	3000	3
/	B-499	F A	-	-	12.70	-	-	B33-603-499	BBP33	B30-R6000HF	3000	3
/	B-499	F A	-	-	12.70	-	-	B33-603-499YL	BBP33	B30-R6000HF	3000	3
/	B-499	F A	-	-	12.70	-	-	BPT-603-499	BBP12, BP-PR+	R7950	3000	3
/	B-499	F A	-	-	12.70	-	-	BPT-603-499YL	BBP12, BP-PR+	R7950	3000	3
/	B-461	F A H S L	-	-	15.24	-	-	B33-604-461AW**	BBP33	B30-R4300	3000	3
✕	B-461	F A H S L	-	-	15.24	-	-	BPT-604-461AW**	BBP12, BP-PR+	R7950	3000	3

**AW = All White / no transparent area.

Vial Top Labels

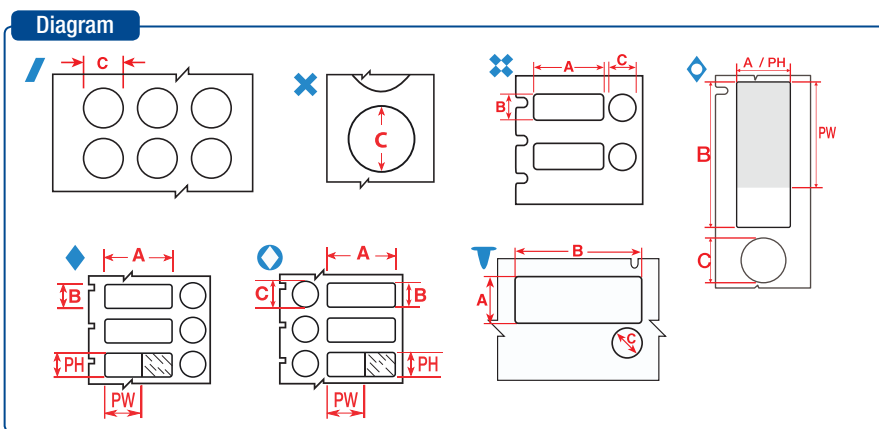

Diagram	Material	Special Properties	Label Width A (mm)	Label Height B (mm)	Diameter C (mm)	Printable Area Width PW (mm)	Printable Area Height PH (mm)	Order Reference	Printer Compatibility	Printer Ribbon Series	Labels/Package	Labels per Row
1.0 - 2.0 ml												
/	B-490	F H L	-	-	12.70	-	-	B33-144-490	BBP33	B30-R4300	2500	3
/	B-492	F H L	-	-	12.70	-	-	B33-144-492	BBP33	B30-R6400	1500	3
/	B-499	F A	-	-	12.70	-	-	B33-144-499	BBP33	B30-R6000HF	1500	3
X	B-499	F A	-	-	12.70	-	-	M71-83-499	BMP71	M71-R4300	500	1
/	B-492	F H L	-	-	12.70	-	-	THT-144-492-3	BBP12, BP-PR+, IP	R6400	3000	3
/	B-499	F A	-	-	12.70	-	-	THT-144-499-3	BBP12, BP-PR+, IP	R4900	3000	3
/	B-492	F H L	-	-	12.70	-	-	THT-144-492-1.5-SC	BBP12, BP-PR+	R6400	1500	3
/	B-499	F A	-	-	12.70	-	-	THT-144-499-1.5-SC	BBP12, BP-PR+	R7950	1500	3
◇	B-461	F A H S L	15.24	41.28	12.70	15.24	30.00	M71-116-461	BMP71	M71-R6200	150	1
⊗	B-492	F H L	25.40	9.53	9.53	-	-	B33-163-492	BBP33	B30-R6400	1500	1
⊗	B-499	F A	25.40	9.53	9.53	-	-	B33-163-499	BBP33	B30-R6000HF	1500	1
⊗	B-492	F H L	25.40	9.53	9.53	-	-	M-118-492	BMP51, BMP53	-	240	1
⊗	B-499	F A	25.40	9.53	9.53	-	-	M-118-499	BMP51, BMP53	-	240	1
⊗	B-492	F H L	25.40	9.53	9.53	-	-	THT-163-492-3	BBP12, BP-PR+, IP	R6400	3000	1
⊗	B-499	F A	25.40	9.53	9.53	-	-	THT-163-499-3	BBP12, BP-PR+, IP	R4900	3000	1
⊗	B-492	F H L	25.40	12.70	9.53	-	-	M71-118-492	BMP71	M71-R6400	500	1
⊗	B-492	F H L	25.40	12.70	9.53	-	-	THT-181-492-3	BBP12, BP-PR+, IP	R6400	3000	1
⊗	B-492	F H L	25.40	12.70	11.18	-	-	B33-182-492	BBP33	B30-R6400	1500	1
⊗	B-492	F H L	25.40	12.70	11.18	-	-	THT-182-492-3	BBP12, BP-PR+, IP	R6400	3000	1
◇	B-461	F A H S L	40.00	15.00	9.00	30.00	15.00	BPTLAB-20-461-2.5	BBP12, BP-PR+	R7950	2500	1
◇	B-461	F A H S L	40.00	15.00	9.53	30.00	15.00	M71-101-461	BMP71	M71-R6200	250	1
⊗	B-499	F A	41.28	15.24	12.70	-	-	BPT-608-499	BBP12, BP-PR+	R7950	1000	1
◇	B-461	F A H S L	41.28	15.24	12.70	30.00	15.24	B33-608-461	BBP33	B30-R4300	1000	1
◇	B-461	F A H S L	41.28	15.24	12.70	30.00	15.24	BPT-608-461	BBP12, BP-PR+	R7950	1000	1
1.0 - 8.0 ml												
⊗	B-490	F H L	22.86	12.70	12.70	-	-	B33-126-490	BBP33	B30-R4300	2500	1
⊗	B-499	F A	22.86	12.70	12.70	-	-	B33-126-499	BBP33	B30-R6000HF	1500	1
⊗	B-499	F A	22.86	12.70	12.70	-	-	M71-126-499	BMP71	M71-R4300	500	1
⊗	B-499	F A	22.86	12.70	12.70	-	-	THT-126-499-3	BBP12, BP-PR+, IP	R4900	3000	1
⊗	B-492	F H L	41.28	15.24	9.53	-	-	B33-190-492	BBP33	R6400	1500	1
⊗	B-492	F H L	41.28	15.24	9.53	-	-	THT-190-492-3	BBP12, BP-PR+, IP	R6400	3000	1
1.5 - 2.0 ml												
X	B-492	F H L	-	-	12.70	-	-	M-83-492	BMP51, BMP53	-	240	1
X	B-499	F A	-	-	12.70	-	-	M-83-499	BMP51, BMP53	-	240	1
X	B-499	F A	-	-	12.70	-	-	M-83-499-OR-BK	BMP51, BMP53	-	240	1
X	B-499	F A	-	-	12.70	-	-	M-83-499-RD-BK	BMP51, BMP53	-	240	1
X	B-499	F A	-	-	12.70	-	-	M-83-499-YL-BK	BMP51, BMP53	-	240	1
⊗	B-492	F H L	25.40	12.70	9.53	-	-	M-120-492	BMP51, BMP53	-	240	1
⊗	B-499	F A	25.40	12.70	9.53	-	-	M-120-499	BMP51, BMP53	-	240	1
⊗	B-492	F H L	25.40	12.70	11.18	-	-	M-117-492	BMP51, BMP53	-	240	1
⊗	B-499	F A	25.40	12.70	11.18	-	-	M-117-499	BMP51, BMP53	-	240	1
∇	B-492	F H L	41.28	15.24	9.53	-	-	M-95-492	BMP51, BMP53	-	200	1

Centrifuge / Microcentrifuge Labels

- F** Freezer environment
- N** Liquid nitrogen environment
- A** Autoclave environment
- H** Hot water bath (100°C)
- S** Self-laminating label
- L** Low-profile (extremely thin) label
- R** Removable

CENTRIFUGE / MICROCENTRIFUGE LABELS

Brady offers a wide range of Centrifuge, Eppendorf and PCR Labels. When applying a self-laminating label, we recommend you avoid touching the adhesive side of the label when wrapping it around a vial or tube, to ensure maximum adhesion.

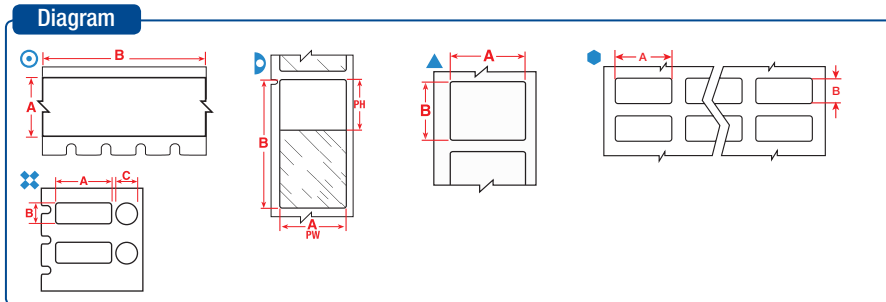
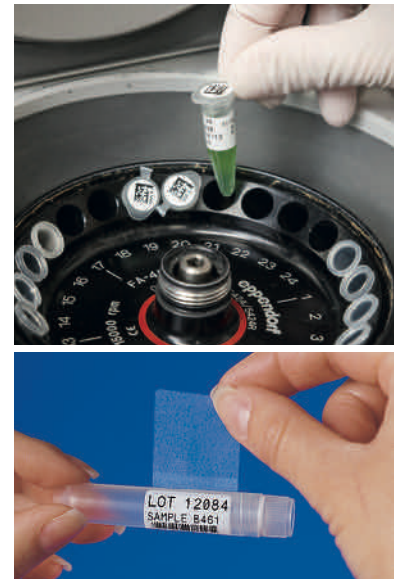

Labels are shown per vial / tube size and in order of label width.

The background colours in the Order Reference column represent the material colour.

See page 38 for Brady's range of label printers.

Diagram	Material	Special Properties	Label Width A (mm)	Label Height B (mm)	Label Length B (m)	Diameter C (mm)	Printable Area Width PW (mm)	Printable Area Height PH (mm)	Order Reference	Printer Compatibility	Printer Ribbon Series	Labels/Package	Labels per Row
0.5 ml													
⊙	B-423	F AH	6.35	—	6.40	—	—	—	M21-250-423	BMP21-LAB	—	1	1
▷	B-461	FNAHSL	6.35	27.94	—	—	6.35	22.00	B33-627-461*	BBP33	B30-R4300	1000	1
▷	B-461	FNAHSL	6.35	27.94	—	—	6.35	22.00	BPT-627-461*	BBP12	R7950	1000	1
0.5 - 0.7 ml													
▷	B-461	FNAHSL	5.08	22.86	—	—	5.08	18.00	BPT-614-461*	BBP12	R7950	2000	1
▷	B-461	FNAHSL	5.08	22.86	—	—	5.08	18.23	B33-614-461*	BBP33	B30-R4300	2000	1
▷	B-461	FNAHSL	9.53	19.05	—	—	9.53	19.05	B33-123-461*	BBP33	B30-R4300	1500	1
▷	B-461	FNAHSL	9.53	19.05	—	—	9.53	19.05	THT-123-461-1.5-SC*	BBP12, BP-PR+	R7950	1500	1
▲	B-498	F R	9.53	25.40	—	—	—	—	M71-16-498	BMP71	M71-R6200	500	1
▲	B-499	FNA	9.53	25.40	—	—	—	—	M71-16-499	BMP71	M71-R4300	500	1
▷	B-461	FNAHSL	9.53	28.58	—	—	9.53	19.05	M-123-461	BMP51, BMP53	—	360	1
▷	B-461	FNAHSL	9.53	45.72	—	—	9.53	19.05	M71-73-461	BMP71	M71-R6200	250	1
▷	B-461	FNAHSL	9.53	45.72	—	—	9.53	19.05	THT-123-461-3*	BBP12, BP-PR+, IP	R4300, R7950	3000	1
⬢	B-490	FNHL	12.70	19.05	—	—	—	—	B33-68-490	BBP33	B30-R4300	2500	4
⬢	B-499	FNA	12.70	19.05	—	—	—	—	B33-68-499	BBP33	B30-R6000HF	1500	4
⬢	B-499	FNA	12.70	19.05	—	—	—	—	THT-68-499-10	BBP12, BP-PR+, IP	R4900	10000	4
▷	B-461	FNAHSL	12.70	28.58	—	—	12.70	19.05	M-122-461	BMP51, BMP53	—	360	1
▷	B-461	FNAHSL	12.70	44.45	—	—	12.70	19.05	M-72-461	BMP51, BMP53	—	180	1
▷	B-461	FNAHSL	12.70	45.72	—	—	12.70	19.05	B33-122-461*	BBP33	B30-R4300	1500	1
▷	B-461	FNAHSL	12.70	45.72	—	—	12.70	19.05	THT-122-461-3*	BBP12, BP-PR+, IP	R4300, R7950	3000	1
▷	B-461	FNAHSL	12.70	45.72	—	—	12.70	19.05	THT-122-461-1.5-SC*	BBP12, BP-PR+	R7950	1500	1
▷	B-461	FNAHSL	12.70	55.88	—	—	12.70	19.05	B33-127-461	BBP33	B30-R4300	1500	3
▷	B-427	FN S	12.70	55.88	—	—	12.70	19.05	THT-127-427-3*	BBP12, BP-PR+, IP	R4300, R7950	3000	1
▷	B-461	FNAHSL	12.70	55.88	—	—	12.70	19.05	THT-127-461-3*	BBP12, BP-PR+, IP	R4300, R7950	3000	1
▷	B-461	FNAHSL	12.70	55.88	—	—	12.70	19.05	THT-127-461-1.5-SC*	BBP12, BP-PR+	R7950	1500	1
▲	B-498	F R	19.05	12.70	—	—	—	—	BM71-11-498	BMP71	M71-R6200	5000	1
▲	B-499	FNA	19.05	12.70	—	—	—	—	BM71-11-499	BMP71	M71-R4300	5000	1
▲	B-499	FNA	19.05	12.70	—	—	—	—	M-11-499	BMP51, BMP53	—	220	1
▲	B-498	F R	19.05	12.70	—	—	—	—	M71-11-498	BMP71	M71-R6200	500	1
▲	B-499	FNA	19.05	12.70	—	—	—	—	M71-11-499	BMP71	M71-R4300	500	1
⬢	B-492	FNHL	25.40	9.53	—	—	—	—	B33-152-492	BBP33	B30-R6400	2500	2
⬢	B-499	FNA	25.40	9.53	—	—	—	—	B33-152-499	BBP33	B30-R6000HF	1500	2
▲	B-492	FNHL	25.40	9.53	—	—	—	—	M71-16-492	BMP71	M71-R6400	500	1
⊘	B-499	FA	25.40	9.53	—	9.53	—	—	M71-98-499	BMP71	M71-R4300	500	1
⬢	B-492	FNHL	25.40	9.53	—	—	—	—	THT-152-492-3	BBP12, BP-PR+, IP	R6400	3000	2

*Label is rotated 90° on liner.

i These labels are also suitable for Eppendorf tubes and PCR process.

Centrifuge / Microcentrifuge Labels

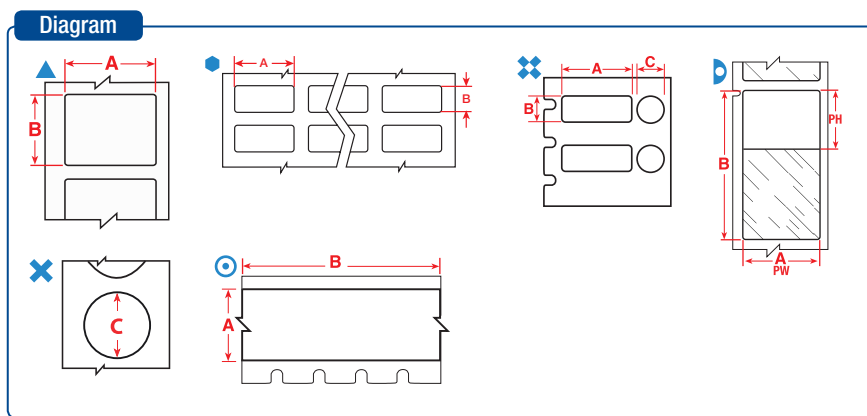

Labels are shown per vial / tube size and in order of label width.

The background colours in the Order Reference column represent the material colour.

See page 38 for Brady's range of label printers.

Diagram	Material	Special Properties	Label Width A (mm)	Label Height B (mm)	Label Length B (m)	Diameter C (mm)	Printable Area Width PW (mm)	Printable Area Height PH (mm)	Order Reference	Printer Compatibility	Printer Ribbon Series	Labels/Package	Labels per Row
0.5 - 0.7 ml													
●	B-499	FNA	25.40	9.53	-	-	-	-	THT-152-499-3	BBP12, BP-PR+, IP	R4900	3000	2
▲	B-492	FNHL	25.40	9.53	-	-	-	-	THT-152-492-2.5-SC	BBP12, BP-PR+	R6400	2500	2
●	B-499	FNA	25.40	9.53	-	-	-	-	THT-152-499-1.5-SC	BBP12, BP-PR+	R7950	1500	2
●	B-425	F	25.40	9.98	-	-	-	-	THT-30-425-10	BBP12, BP-PR+, IP	R6400	10000	3
▲	B-490	FNHL	31.75	9.53	-	-	-	-	B33-154-490	BBP33	B30-R4300	1500	1
▲	B-490	FNHL	31.75	9.53	-	-	-	-	M-112-490	BMP51, BMP53	-	360	1
▲	B-492	FNHL	31.75	9.53	-	-	-	-	M-112-492	BMP51, BMP53	-	360	1
▲	B-490	FNHL	31.75	9.53	-	-	-	-	THT-154-490-3	BBP12, BP-PR+, IP	R4306	3000	1
▲	B-490	FNHL	31.75	9.53	-	-	-	-	THT-154-490-1.5-SC	BBP12, BP-PR+	R7950	1500	1
0.5 - 1.5 ml													
×	B-492	FHL	-	-	-	9.53	-	-	M-82-492	BMP51, BMP53	-	240	1
×	B-499	FA	-	-	-	9.53	-	-	M-82-499-RD-BK	BMP51, BMP53	-	240	1
0.6 ml													
○	B-499	FNA	9.53	-	4.88	-	-	-	M21-375-499	BMP21-LAB	-	1	1
○	B-499	FNA	9.53	-	4.88	-	-	-	MC-375-499	BMP51, BMP53	-	1	1
○	B-461	FNAHSL	9.53	-	6.40	-	9.53	-	M21-375-461-AW**	BMP21-LAB	-	1	1
▲	B-492	FNHL	9.53	20.96	-	-	-	-	M-130-492	BMP51, BMP53	-	220	1
▲	B-499	FNA	9.53	20.96	-	-	-	-	M-130-499	BMP51, BMP53	-	220	1
▲	B-499	FNA	22.86	12.70	-	-	-	-	M71-84-499	BMP71	M71-R4300	500	1
▲	B-499	FNA	22.86	12.70	-	-	-	-	M-84-499	BMP51, BMP53	-	200	1
▲	B-492	FNHL	31.75	6.35	-	-	-	-	M-155-492	BMP51, BMP53	-	180	1
1.0 - 2.0 ml													
⊗	B-492	FHL	25.40	9.53	-	9.53	-	-	M-118-492	BMP51, BMP53	-	240	1
⊗	B-499	FA	25.40	9.53	-	9.53	-	-	M-118-499	BMP51, BMP53	-	240	1
1.0 - 8.0 ml													
▲	B-490	FNHL	41.28	15.24	-	-	-	-	THT-155-490-3	BBP12, BP-PR+, IP	R4300, R7950	3000	1
▲	B-492	FNHL	12.70	25.40	-	-	-	-	M-131-492	BMP51, BMP53	-	180	1
▲	B-499	FNA	12.70	25.40	-	-	-	-	M-131-499	BMP51, BMP53	-	180	1
▷	B-461	FNAHSL	12.70	55.88	-	-	12.70	19.05	M-74-461	BMP51, BMP53	-	140	1
▷	B-461	FNAHSL	15.24	41.28	-	-	15.24	25.40	M71-76-461	BMP71	M71-R6200	500	1
▲	B-490	FNHL	15.24	45.72	-	-	-	-	M-126-490	BMP51, BMP53	-	180	1
▷	B-461	FNAHSL	15.24	45.72	-	-	15.24	25.40	M-126-461	BMP51, BMP53	-	180	1
▷	B-461	FNAHSL	15.24	66.68	-	-	15.24	25.40	B33-153-461*	BBP33	B30-R4300	1500	1
▷	B-461	FNAHSL	15.24	66.68	-	-	15.24	25.40	M71-86-461	BMP71	M71-R6200	100	1
▷	B-461	FNAHSL	15.24	66.68	-	-	15.24	25.40	M-86-461	BMP51, BMP53	-	120	1
⊗	B-499	FA	22.86	12.70	-	12.70	-	-	M71-126-499	BMP71	M71-R4300	500	1
⊗	B-499	FA	22.86	12.70	-	12.70	-	-	THT-126-499-3	BBP12, BP-PR+, IP	R4900	3000	1
▲	B-490	FNHL	41.28	15.24	-	-	-	-	B33-155-490	BBP33	B30-R4300	1500	1

*Label is rotated 90° on liner. **AW = All White / no transparent area.

i These labels are also suitable for Eppendorf tubes and PCR process.

Centrifuge / Microcentrifuge Labels

Diagram

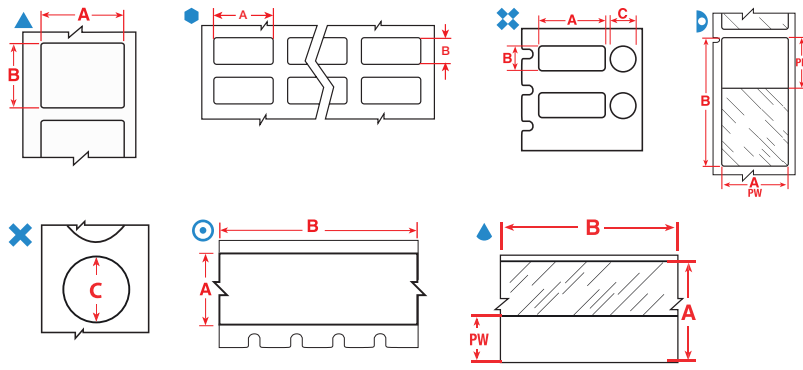
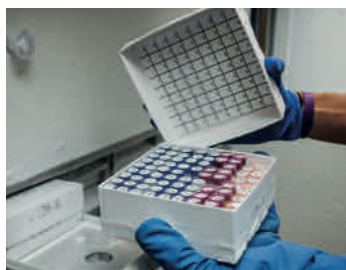

Diagram	Material	Special Properties	Label Width A (mm)	Label Height B (mm)	Label Length B (m)	Diameter C (mm)	Printable Area Width PW (mm)	Printable Area Height PH (mm)	Order Reference	Printer Compatibility	Printer Ribbon Series	Labels/Package	Labels per Row
1.0 - 8.0 ml													
▲	B-492	F N H L	41.28	15.24	-	-	-	-	B33-155-492	BBP33	R6400	1500	1
▲	B-490	F N H L	41.28	15.24	-	-	-	-	M71-76-490	BMP71	M71-R4300	500	1
▲	B-490	F N H L	41.28	15.24	-	-	-	-	THT-155-490-1.5-SC	BBP12, BP-PR+	R7950	1500	1
▲	B-492	F N H L	41.28	15.24	-	-	-	-	THT-155-492-3	BBP12, BP-PR+, IP	R6400	3000	1
1.5 ml													
⊙	B-499	F N A	12.70	-	4.88	-	-	-	M21-500-499	BMP21-LAB	-	1	1
⊙	B-499	F N A	12.70	-	4.88	-	-	-	MC-500-499	BMP51, BMP53	-	1	1
⊙	B-461	F N A H S L	12.70	-	6.40	-	12.70	-	M21-500-461-AW**	BMP21-LAB	-	1	1
⊙	B-492	F N H L	12.70	-	7.62	-	-	-	MC-500-492	BMP51, BMP53	-	1	1
⊙	B-461	F N A H S L	12.70	-	7.62	-	12.70	-	MC-500-461-AW**	BMP51, BMP53	-	1	1
⊙	B-499	F N A	12.70	-	9.10	-	-	-	M71C-500-499	BMP71	M71-R4300	1	1
1.5 - 2.0 ml													
×	B-492	F H L	-	-	-	12.70	-	-	M-83-492	BMP51, BMP53	-	240	1
×	B-499	F A	-	-	-	12.70	-	-	M-83-499-OR-BK	BMP51, BMP53	-	240	1
×	B-499	F A	-	-	-	12.70	-	-	M-83-499-RD-BK	BMP51, BMP53	-	240	1
▲	B-490	F N H L	12.70	41.91	-	-	-	-	M-124-490	BMP51, BMP53	-	180	1
▷	B-461	F N A H S L	12.70	41.91	-	-	12.70	19.05	M-124-461	BMP51, BMP53	-	180	1
▷	B-461	F N A H S L	15.24	41.28	-	-	15.24	25.40	THT-133-461-1.5-SC*	BBP12, BP-PR+	R7950	1500	1
▷	B-461	F N A H S L	15.24	41.28	-	-	15.24	25.40	THT-133-461-3*	BBP12, BP-PR+, IP	R4300, R7950	3000	1
▷	B-461	F N A H S L	15.24	66.68	-	-	15.24	25.40	THT-153-461-1.5-SC*	BBP12, BP-PR+	R7950	1500	1
▷	B-461	F N A H S L	15.24	66.68	-	-	15.24	25.40	THT-153-461-3*	BBP12, BP-PR+, IP	R4300, R7950	3000	1
▲	B-492	F N H L	25.40	12.70	-	-	-	-	B33-59-492	BBP33	B30-R6400	2500	1
▲	B-492	F N H L	25.40	12.70	-	-	-	-	THT-59-492-10	BBP12, BP-PR+, IP	R6400	10000	1
▲	B-492	F N H L	25.40	12.70	-	-	-	-	THT-59-492-2.5-SC	BBP12, BP-PR+	R6400	2500	1
⊗	B-492	F H L	25.40	12.70	-	9.53	-	-	M-120-492	BMP51, BMP53	-	240	1
⊗	B-499	F A	25.40	12.70	-	9.53	-	-	M-120-499	BMP51, BMP53	-	240	1
⊗	B-492	F H L	25.40	12.70	-	11.18	-	-	M-117-492	BMP51, BMP53	-	240	1
⊗	B-499	F A	25.40	12.70	-	11.18	-	-	M-117-499	BMP51, BMP53	-	240	1
▲	B-492	F N H L	41.91	12.70	-	-	-	-	M-124-492	BMP51, BMP53	-	180	1
2.0 - 50.0 ml													
▲	B-427	F N S	19.05	-	4.30	-	9.53	-	M21-750-427	BMP21-PLUS; BMP21	-	1	-
⊙	B-499	F N A	19.05	-	4.88	-	-	-	M21-750-499	BMP21-LAB	-	1	1
⊙	B-499	F N A	19.05	-	4.88	-	-	-	MC-750-499	BMP51, BMP53	-	1	1
⊙	B-461	F N A H S L	19.05	-	6.40	-	19.05	-	M21-750-461-AW**	BMP21-LAB	-	1	1
▲	B-427	F N S	19.05	-	7.62	-	9.53	-	MC-750-427	BMP51, BMP53	-	1	1
⊙	B-499	F N A	25.40	-	4.88	-	-	-	MC-1000-499	BMP51, BMP53	-	1	1
⊙	B-499	F N A	25.40	-	9.10	-	-	-	M71C-1000-499	BMP71	M71-R4300	1	1
5.0 - 50.0 ml													
⊙	B-499	F N A	48.26	-	9.10	-	-	-	M71C-1900-499	BMP71	M71-R4300	1	1

*Label is rotated 90° on liner. **AW = All White / no transparent area.

i These labels are also suitable for Eppendorf tubes and PCR process.

Cryo Tubes & Vials



CRYO TUBES & VIALS

Brady's offers a range of labels designed specifically to identify laboratory samples for cryo storage. These labels can be applied to room temperature or to already frozen samples, albeit with a small overlap. The label will remain legible and will stick to the sample container during processing, even when exposed to extreme heat or chemicals like DMSO, Xylene and Ethanol, ensuring secure sample identification in the most challenging laboratory conditions.

- F** Freezer environment
- N** Liquid nitrogen environment
- A** Autoclave environment
- H** Hot water bath (100°C)
- S** Self-laminating label
- L** Low-profile (extremely thin) label
- R** Removable

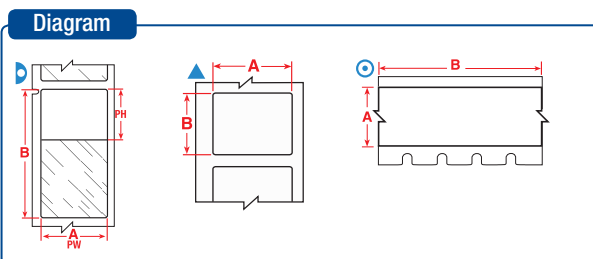

The background colours in the Order Reference column represent the material colour

See page 38 for Brady's range of label printers.

Labels are shown per vial / tube size and in order of label width.

Diagram	Material	Special Properties	Label Width A (mm)	Label Height B (mm)	Label Length B (m)	Printable Area Width PW (mm)	Printable Area Height PH (mm)	Order Reference	Printer Compatibility	Printer Ribbon Series	Labels/Package	Labels per Row
0.5 - 0.7 ml												
▶	B-461	F N A H S L	9.53	28.58	–	9.53	19.05	M-123-461	BMP51, BMP53	–	360	1
▶	B-461	F N A H S L	12.70	28.58	–	12.70	19.05	M-122-461	BMP51, BMP53	–	360	1
▶	B-461	F N A H S L	12.70	44.45	–	12.70	19.05	M-72-461	BMP51, BMP53	–	180	1
▲	B-499	F N A	19.05	12.70	–	–	–	BM71-11-499	BMP71	M71-R4300	5000	1
▲	B-499	F N A	19.05	12.70	–	–	–	M-11-499	BMP51, BMP53	–	220	1
▲	B-499	F N A	19.05	12.70	–	–	–	M71-11-499	BMP71	M71-R4300	500	1
▲	B-490	F N H L	31.75	9.53	–	–	–	M-112-490	BMP51, BMP53	–	360	1
0.6 ml												
⊙	B-499	F N A	9.53	–	4.88	–	–	M21-375-499	BMP21-LAB	–	1	1
⊙	B-499	F N A	9.53	–	4.88	–	–	MC-375-499	BMP51, BMP53	–	1	1
⊙	B-461	F N A H S L	9.53	–	6.40	9.53	–	M21-375-461-AW**	BMP21-LAB	–	1	1
⊙	B-461	F N A H S L	9.53	–	7.62	9.53	–	MC-375-461-AW**	BMP51, BMP53	–	1	1
▲	B-492	F N H L	9.53	20.96	–	–	–	M-130-492	BMP51, BMP53	–	220	1
▲	B-499	F N A	9.53	20.96	–	–	–	M-130-499	BMP51, BMP53	–	220	1
▲	B-499	F N A	22.86	12.70	–	–	–	M-84-499	BMP51, BMP53	–	200	1
1.0 - 8.0 ml												
▲	B-492	F N H L	12.70	25.40	–	–	–	M-131-492	BMP51, BMP53	–	180	1
▲	B-499	F N A	12.70	25.40	–	–	–	M-131-499	BMP51, BMP53	–	180	1
▶	B-461	F N A H S L	12.70	55.88	–	12.70	19.05	M-74-461	BMP51, BMP53	–	140	1
▲	B-490	F N H L	15.24	45.72	–	–	–	M-126-490	BMP51, BMP53	–	180	1
▶	B-461	F N A H S L	15.24	45.72	–	15.24	25.40	M-126-461	BMP51, BMP53	–	180	1
▶	B-461	F N A H S L	15.24	66.68	–	15.24	25.40	M-86-461	BMP51, BMP53	–	120	1
▲	B-490	F N H L	25.40	44.45	–	–	–	M-125-490	BMP51, BMP53	–	180	1
▶	B-461	F N A H S L	25.40	44.45	–	25.40	25.40	M-125-461	BMP51, BMP53	–	180	1
▶	B-461	F N A H S L	25.40	66.68	–	25.40	25.40	BM71-75-461	BMP71	M71-R6200	1000	1
▶	B-461	F N A H S L	25.40	66.68	–	25.40	25.40	M-75-461	BMP51, BMP53	–	120	1

**AW = All White / no transparent area.

>>

i Part number explanation

Most Brady references for printable labels follow the same three-part format: The first code indicates the technology, the second part is a number indicating the label size (where applicable) and the third part indicates the Brady material (where applicable).

M71-73-461

BMP71
Technology

Label size
code

Material
(B-number)

Diagram

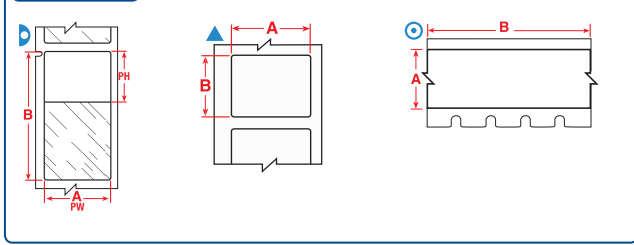

Labels are shown per vial / tube size and in order of label width.

The background colours in the Order Reference column represent the material colour.

See page 38 for Brady's range of label printers.

Diagram	Material	Special Properties	Label Width A (mm)	Label Height B (mm)	Label Length B (m)	Printable Area Width PW (mm)	Printable Area Height PH (mm)	Order Reference	Printer Compatibility	Printer Ribbon Series	Labels/Package	Labels per Row
1.0 - 15 ml												
▲	B-492	F N H L	22.86	25.40	-	-	-	M-156-492	BMP51, BMP53	-	180	1
1.5 ml												
◎	B-499	F N A	12.70	-	4.88	-	-	M21-500-499	BMP21-LAB	-	1	1
◎	B-499	F N A	12.70	-	4.88	-	-	MC-500-499	BMP51, BMP53	-	1	1
◎	B-461	F N A H S L	12.70	-	6.40	12.70	-	M21-500-461-AW**	BMP21-LAB	-	1	1
◎	B-461	F N A H S L	12.70	-	7.62	12.70	-	MC-500-461-AW**	BMP51, BMP53	-	1	1
◎	B-499	F N A	12.70	-	9.10	-	-	M71C-500-499	BMP71	M71-R4300	1	1
2.0 - 50.0 ml												
◎	B-499	F N A	19.05	-	4.88	-	-	M21-750-499	BMP21-LAB	-	1	1
◎	B-499	F N A	19.05	-	4.88	-	-	MC-750-499	BMP51, BMP53	-	1	1
◎	B-461	F N A H S L	19.05	-	6.40	19.05	-	M21-750-461-AW**	BMP21-LAB	-	1	1
◎	B-499	F N A	25.40	-	4.88	-	-	MC-1000-499	BMP51, BMP53	-	1	1
◎	B-461	F N A H S L	25.40	-	7.62	25.40	-	MC-1000-461-AW**	BMP51, BMP53	-	1	1
◎	B-499	F N A	25.40	-	9.10	-	-	M71C-1000-499	BMP71	M71-R4300	1	1
4.0 - 50.0 ml												
◎	B-461	F N A H S L	31.75	-	7.62	31.75	-	MC-1250-461-AW**	BMP51, BMP53	-	1	1
12.0 - 14.0 ml												
▶	B-461	F N A H S L	38.10	95.25	-	38.10	31.75	M-119-461	BMP51, BMP53	-	80	1
12.0 - 24.0 ml												
▲	B-492	F N H L	25.40	48.26	-	-	-	M-78-492	BMP51, BMP53	-	100	1
▲	B-499	F N A	38.10	12.70	-	-	-	M71-29-499	BMP71	M71-R4300	500	1
▲	B-499	F N A	38.10	31.75	-	-	-	M-132-499	BMP51, BMP53	-	160	1

**AW = All White / no transparent area.



B-492 (FreezerBondz™)

“The special FreezerBondz™ labels are very reliable: they stick to the glass vials we use for our frozen fish tissue samples and, just as important, they remain readable to maintain accurate sample identification in long-term storage.”

Centre for Ecology & Hydrology, UK



Conical / Large Tube Labels



CONICAL / LARGE TUBE LABELS

Brady offers several sample identification labels which are perfect to identify conicals. They are easy to handle, have great flexibility and easily wrap around curved sample containers. Your sample identification label will remain attached and legible, even when the sample is stored in a freezer, in liquid nitrogen or heated in an autoclave.

- F** Freezer environment
- N** Liquid nitrogen environment
- A** Autoclave environment
- H** Hot water bath (100°C)
- S** Self-laminating label
- L** Low-profile (extremely thin) label
- R** Removable

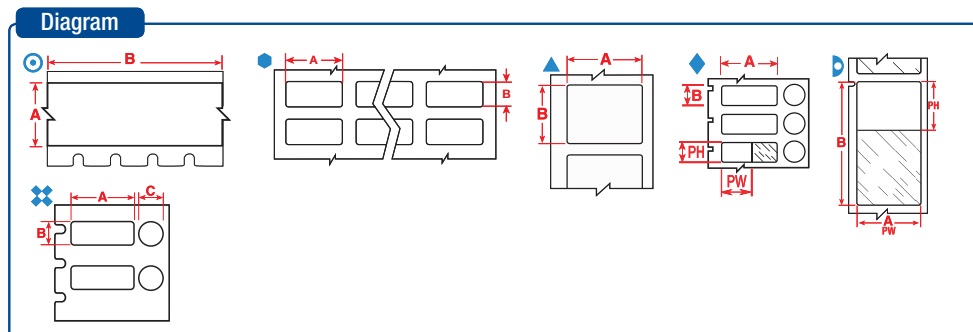

Labels are shown per vial / tube size and in order of label width.

The background colours in the Order Reference column represent the material colour.

See page 38 for Brady's range of label printers.

Diagram	Material	Special Properties	Label Width A (mm)	Label Height B (mm)	Label Length B (m)	Diameter C (mm)	Printable Area Width PW (mm)	Printable Area Height PH (mm)	Order Reference	Printer Compatibility	Printer Ribbon Series	Labels/Package	Labels per Row
0.5 ml													
○	B-423	F A H	6.35	-	6.40	-	-	-	M21-250-423	BMP21-LAB	-	1	1
0.5 - 0.7 ml													
●	B-499	F N A	12.70	19.05	-	-	-	-	B33-68-499	BBP33	B30-R6000HF	1500	4
●	B-499	F N A	12.70	19.05	-	-	-	-	THT-68-499-10	BBP12, BP-PR+, IP	R4900	10000	4
▲	B-499	F N A	12.70	25.40	-	-	-	-	B33-620-499	BBP33	B30-R6000HF	1000	1
▲	B-499	F N A	12.70	25.40	-	-	-	-	BPT-620-499	BBP12, BP-PR+	R7950	1000	1
▷	B-461	F N A H S L	12.70	55.88	-	-	12.70	19.05	B33-127-461	BBP33	B30-R4300	1500	3
▷	B-427	F N S	12.70	55.88	-	-	12.70	19.05	THT-127-427-3*	BBP12, BP-PR+, IP	R4300, R7950	3000	1
▷	B-461	F N A H S L	12.70	55.88	-	-	12.70	19.05	THT-127-461-1.5-SC*	BBP12, BP-PR+	R7950	1500	1
▷	B-461	F N A H S L	12.70	55.88	-	-	12.70	19.05	THT-127-461-3*	BBP12, BP-PR+, IP	R4300, R7950	3000	1
▲	B-499	F N A	19.05	12.70	-	-	-	-	M71-11-499	BMP71	M71-R4300	500	1
●	B-492	F N H L	25.40	9.53	-	-	-	-	B33-152-492	BBP33	B30-R6400	2500	2
●	B-499	F N A	25.40	9.53	-	-	-	-	B33-152-499	BBP33	B30-R6000HF	1500	2
▲	B-492	F N H L	25.40	9.53	-	-	-	-	M71-16-492	BMP71	M71-R6400	500	1
▲	B-492	F N H L	25.40	9.53	-	-	-	-	THT-152-492-2.5-SC	BBP12, BP-PR+	R6400	2500	2
●	B-492	F N H L	25.40	9.53	-	-	-	-	THT-152-492-3	BBP12, BP-PR+, IP	R6400	3000	2
●	B-499	F N A	25.40	9.53	-	-	-	-	THT-152-499-1.5-SC	BBP12, BP-PR+	R7950	1500	2
●	B-499	F N A	25.40	9.53	-	-	-	-	THT-152-499-3	BBP12, BP-PR+, IP	R4900	3000	2
✕	B-499	F A	25.40	9.53	-	9.53	-	-	M71-98-499	BMP71	M71-R4300	500	1
◆	B-461	F A H S L	25.40	9.53	-	9.53	20.00	9.53	B33-606-461	BBP33	B30-R4300	1000	1
◆	B-461	F A H S L	25.40	9.53	-	9.53	20.00	9.53	BPT-606-461	BBP12, BP-PR+	R7950	1000	1
●	B-425	F	25.40	9.98	-	-	-	-	THT-30-425-10	BBP12, BP-PR+, IP	R6400	10000	3
0.5 - 8.0 ml													
✕	B-492	F H L	25.40	9.53	-	9.53	-	-	THT-249-492-1.5-SC	BBP12, BP-PR+	R6400	1500	1
✕	B-499	F A	25.40	9.53	-	9.53	-	-	THT-249-499-1.5-SC	BBP12, BP-PR+	R7950	1500	1
✕	B-492	F H L	25.40	12.70	-	9.53	-	-	THT-250-492-1.5-SC	BBP12, BP-PR+	R6400	1500	1
✕	B-492	F H L	25.40	12.70	-	11.18	-	-	THT-251-492-1.5-SC	BBP12, BP-PR+	R6400	1500	1
0.6 ml													
○	B-499	F N A	9.53	-	4.88	-	-	-	M21-375-499	BMP21-LAB	-	1	1
○	B-499	F N A	9.53	-	4.88	-	-	-	MC-375-499	BMP51, BMP53	-	1	1
○	B-461	F N A H S L	9.53	-	6.40	-	9.53	-	M21-375-461-AW**	BMP21-LAB	-	1	1
▲	B-499	F N A	22.86	12.70	-	-	-	-	B33-125-499	BBP33	B30-R6000HF	1500	1
▲	B-499	F N A	22.86	12.70	-	-	-	-	M71-84-499	BMP71	M71-R4300	500	1
▲	B-499	F N A	22.86	12.70	-	-	-	-	THT-125-499-1.5-SC	BBP12, BP-PR+	R7950	1500	1
▲	B-499	F N A	22.86	12.70	-	-	-	-	THT-125-499-3	BBP12, BP-PR+, IP	R4900	3000	1

*Label is rotated 90° on liner. **AW = All White / no transparent area.

Conical / Large Tube Labels

Diagram

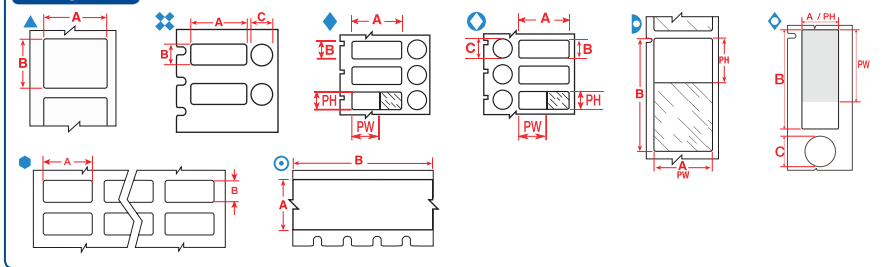
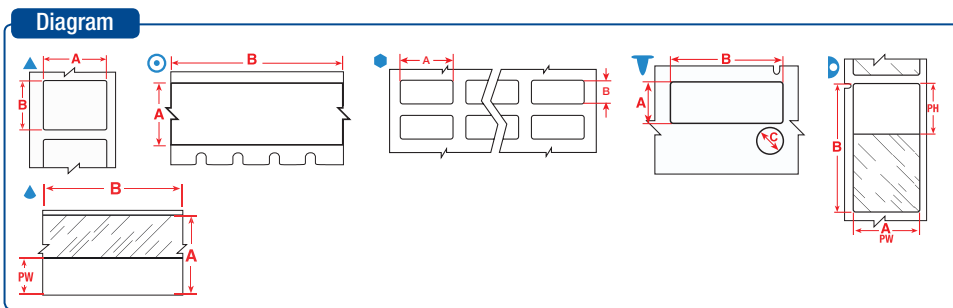

Diagram	Material	Special Properties	Label Width A (mm)	Label Height B (mm)	Label Length B (m)	Diameter C (mm)	Printable Area Width PW (mm)	Printable Area Height PH (mm)	Order Reference	Printer Compatibility	Printer Ribbon Series	Labels/Package	Labels per Row
1.0 - 2.0 ml													
▷	B-461	FNAHSL	15.00	40.00	-	-	15.00	30.00	BPTLAB-21-461-2.5	BBP12, BP-PR+	R7950	2500	1
▷	B-461	FNAHSL	15.24	38.10	-	-	15.24	33.00	BPT-628-461*	BBP12, BP-PR+	R7950	2500	2
▷	B-461	FNAHSL	15.24	38.10	-	-	15.24	33.00	M71-100-461	BMP71	M71-R6200	500	1
▷	B-461	FNAHSL	15.24	38.10	-	-	15.24	33.03	B33-628-461*	BBP33	B30-R4300	2500	2
◊	B-461	F AHSL	15.24	41.28	-	12.70	15.24	30.00	M71-116-461	BMP71	M71-R6200	150	1
▷	B-461	FNAHSL	15.24	66.68	-	-	15.24	25.40	B33-612-461	BBP33	B30-R4300	1500	3
▷	B-461	FNAHSL	15.24	66.68	-	-	15.24	25.40	BPT-612-461	BBP12, BP-PR+	R7950	1500	3
⊗	B-492	F H L	25.40	9.53	-	9.53	-	-	THT-163-492-3	BBP12, BP-PR+, IP	R6400	3000	1
⊗	B-499	F A	25.40	9.53	-	9.53	-	-	THT-163-499-3	BBP12, BP-PR+, IP	R4900	3000	1
⊗	B-492	F H L	25.40	12.70	-	9.53	-	-	M71-118-492	BMP71	M71-R6400	500	1
⊗	B-492	F H L	25.40	12.70	-	9.53	-	-	THT-181-492-3	BBP12, BP-PR+, IP	R6400	3000	1
⊗	B-492	F H L	25.40	12.70	-	11.18	-	-	THT-182-492-3	BBP12, BP-PR+, IP	R6400	3000	1
◆	B-461	F AHSL	40.00	15.00	-	9.00	30.00	15.00	BPTLAB-20-461-2.5	BBP12, BP-PR+	R7950	2500	1
◆	B-461	F AHSL	40.00	15.00	-	9.53	30.00	15.00	M71-101-461	BMP71	M71-R6200	250	1
⊗	B-499	F A	41.28	15.24	-	12.70	-	-	BPT-608-499	BBP12, BP-PR+	R7950	1000	1
◊	B-461	F AHSL	41.28	15.24	-	12.70	30.00	15.24	B33-608-461	BBP33	B30-R4300	1000	1
◆	B-461	F AHSL	41.28	15.24	-	12.70	30.00	15.24	BPT-608-461	BBP12, BP-PR+	R7950	1000	1
1.0 - 8.0 ml													
▷	B-461	FNAHSL	15.24	41.28	-	-	15.24	25.40	M71-76-461	BMP71	M71-R6200	500	1
▷	B-461	FNAHSL	15.24	66.68	-	-	15.24	25.40	M71-86-461	BMP71	M71-R6200	100	1
▷	B-427	FN S	19.05	44.45	-	-	19.05	12.70	B33-73-427	BBP33	B30-R4300	3500	4
▷	B-427	FN S	19.05	44.45	-	-	19.05	12.70	THT-62-427-3.5*	BBP12, BP-PR+, IP	R4300, R7950	3500	1
▷	B-427	FN S	19.05	44.45	-	-	19.05	12.70	THT-73-427-10	BBP12, BP-PR+, IP	R4300, R7950	10000	4
▲	B-427	FN S	20.00	20.00	-	-	20.00	20.00	BPTLAB-35-427-YL	BBP12, BP-PR+	R7950	1000	1
⊗	B-499	F A	22.86	12.70	-	12.70	-	-	B33-126-499	BBP33	B30-R6000HF	1500	1
⊗	B-499	F A	22.86	12.70	-	12.70	-	-	M71-126-499	BMP71	M71-R4300	500	1
⊗	B-499	F A	22.86	12.70	-	12.70	-	-	THT-126-499-3	BBP12, BP-PR+, IP	R4900	3000	1
▲	B-492	FN H L	25.40	19.05	-	-	-	-	THT-88-492-2.5-SC	BBP12, BP-PR+	R6400	2500	2
▲	B-492	FN H L	25.40	19.05	-	-	-	-	THT-88-492-5	BBP12, BP-PR+, IP	R6400	5000	2
▷	B-461	FNAHSL	25.40	66.68	-	-	25.40	25.40	BM71-75-461	BMP71	M71-R6200	1000	1
▷	B-461	FNAHSL	25.40	66.68	-	-	25.40	25.40	M71-115-461	BMP71	M71-R6200	100	1
▷	B-461	FNAHSL	25.40	66.68	-	-	25.40	25.40	THT-131-461-1.5-SC*	BBP12, BP-PR+	R7950	1500	1
▷	B-461	FNAHSL	25.40	66.68	-	-	25.40	25.40	THT-131-461-3*	BBP12, BP-PR+, IP	R4300, R7950	3000	1
▲	B-490	FN H L	41.28	15.24	-	-	-	-	B33-155-490	BBP33	B30-R4300	1500	1
▲	B-492	FN H L	41.28	15.24	-	-	-	-	B33-155-492	BBP33	R6400	1500	1
▲	B-490	FN H L	41.28	15.24	-	-	-	-	M71-76-490	BMP71	M71-R4300	500	1
▲	B-490	FN H L	41.28	15.24	-	-	-	-	THT-155-490-1.5-SC	BBP12, BP-PR+	R7950	1500	1
▲	B-490	FN H L	41.28	15.24	-	-	-	-	THT-155-490-3	BBP12, BP-PR+, IP	R4300, R7950	3000	1
▲	B-492	FN H L	41.28	15.24	-	-	-	-	THT-155-492-3	BBP12, BP-PR+, IP	R6400	3000	1
⊗	B-492	F H L	41.28	15.24	-	9.53	-	-	B33-190-492	BBP33	R6400	1500	1
⊗	B-492	F H L	41.28	15.24	-	9.53	-	-	THT-190-492-3	BBP12, BP-PR+, IP	R6400	3000	1
▲	B-492	FN H L	44.45	25.40	-	-	-	-	M-125-492	BMP51, BMP53	-	180	1
▲	B-490	FN H L	48.26	25.40	-	-	-	-	B33-156-490	BBP33	B30-R4300	1500	1
▲	B-492	FN H L	48.26	25.40	-	-	-	-	B33-156-492	BBP33	B30-R6400	1500	1
▲	B-492	FN H L	48.26	25.40	-	-	-	-	M71-78-492	BMP71	M71-R6400	250	1
▲	B-499	FNA	48.26	25.40	-	-	-	-	M71-78-499	BMP71	M71-R4300	250	1
▲	B-490	FN H L	48.26	25.40	-	-	-	-	THT-156-490-1.5-SC	BBP12, BP-PR+	R7950	1500	1
▲	B-490	FN H L	48.26	25.40	-	-	-	-	THT-156-490-3	BBP12, BP-PR+, IP	R4300, R7950	3000	1
▲	B-492	FN H L	48.26	25.40	-	-	-	-	THT-156-492-1.5-SC	BBP12, BP-PR+	R6400	1500	1
▲	B-492	FN H L	48.26	25.40	-	-	-	-	THT-156-492-3	BBP12, BP-PR+, IP	R6400	3000	1

*Label is rotated 90° on liner.

Conical / Large Tube Labels



Labels are shown per vial / tube size and in order of label width.

The background colours in the Order Reference column represent the material colour.

See page 38 for Brady's range of label printers.

Diagram	Material	Special Properties	Label Width A (mm)	Label Height B (mm)	Label Length B (m)	Diameter C (mm)	Printable Area Width PW (mm)	Printable Area Height PH (mm)	Order Reference	Printer Compatibility	Printer Ribbon Series	Labels/Package	Labels per Row
1.0 - 15 ml													
▲	B-492	F N H L	22.86	25.40	-	-	-	-	M-156-492	BMP51, BMP53	-	180	1
1.5 ml													
○	B-499	F N A	12.70	-	4.88	-	-	-	M21-500-499	BMP21-LAB	-	1	1
○	B-499	F N A	12.70	-	4.88	-	-	-	MC-500-499	BMP51, BMP53	-	1	1
○	B-461	F N A H S L	12.70	-	6.40	-	12.70	-	M21-500-461-AW**	BMP21-LAB	-	1	1
○	B-499	F N A	12.70	-	9.10	-	-	-	M71C-500-499	BMP71	M71-R4300	1	1
1.5 - 2.0 ml													
▷	B-461	F N A H S L	15.24	41.28	-	-	15.24	25.40	B33-133-461	BBP33	B30-R4300	1500	3
▷	B-461	F N A H S L	15.24	41.28	-	-	15.24	25.40	THT-133-461-1.5-SC*	BBP12, BP-PR+	R7950	1500	1
▷	B-461	F N A H S L	15.24	41.28	-	-	15.24	25.40	THT-133-461-3*	BBP12, BP-PR+, IP	R4300, R7950	3000	1
▷	B-461	F N A H S L	15.24	66.68	-	-	15.24	25.40	THT-153-461-1.5-SC*	BBP12, BP-PR+	R7950	1500	1
▷	B-461	F N A H S L	15.24	66.68	-	-	15.24	25.40	THT-153-461-3*	BBP12, BP-PR+, IP	R4300, R7950	3000	1
▲	B-492	F N H L	25.40	12.70	-	-	-	-	B33-59-492	BBP33	B30-R6400	2500	1
●	B-430	F A H	25.40	12.70	-	-	-	-	THT-39-430-10	BBP12, BP-PR+, IP	R6000	10000	3
▲	B-492	F N H L	25.40	12.70	-	-	-	-	THT-59-492-10	BBP12, BP-PR+, IP	R6400	10000	1
▲	B-492	F N H L	25.40	12.70	-	-	-	-	THT-59-492-2.5-SC	BBP12, BP-PR+	R6400	2500	1
▽	B-492	F H L	41.28	15.24	-	9.53	-	-	M-95-492	BMP51, BMP53	-	200	1
▲	B-492	F N H L	41.91	12.70	-	-	-	-	M-124-492	BMP51, BMP53	-	180	1
2.0 - 4.0 ml													
▷	B-461	F N A H S L	15.24	48.26	-	-	15.24	40.00	B33-638-461*	BBP33	B30-R4300	2000	1
▷	B-461	F N A H S L	15.24	48.26	-	-	15.24	40.00	BPT-638-461*	BBP12, BP-PR+	R7950	2000	1
▷	B-461	F N A H S L	15.24	48.26	-	-	15.24	40.00	M71-119-461	BMP71	M71-R6200	500	1
2.0 - 50.0 ml													
▲	B-427	F N S	19.05	-	4.30	-	9.53	-	M21-750-427	BMP21-LAB	-	1	-
○	B-499	F N A	19.05	-	4.88	-	-	-	M21-750-499	BMP21-LAB	-	1	1
○	B-499	F N A	19.05	-	4.88	-	-	-	MC-750-499	BMP51, BMP53	-	1	1
○	B-461	F N A H S L	19.05	-	6.40	-	19.05	-	M21-750-461-AW**	BMP21-LAB	-	1	1
▲	B-427	F N S	19.05	-	7.62	-	9.53	-	MC-750-427	BMP51, BMP53	-	1	1
▲	B-427	F N S	25.40	-	4.30	-	9.53	-	M21-1000-427	BMP21-LAB	-	1	-
○	B-499	F N A	25.40	-	4.88	-	-	-	MC-1000-499	BMP51, BMP53	-	1	1
▲	B-427	F N S	25.40	-	7.62	-	9.53	-	MC-1000-427	BMP51, BMP53	-	1	1
○	B-461	F N A H S L	25.40	-	7.62	-	25.40	-	MC-1000-461-AW**	BMP51, BMP53	-	1	1
○	B-499	F N A	25.40	-	9.10	-	-	-	M71C-1000-499	BMP71	M71-R4300	1	1
4.0 - 8.0 ml													
●	B-499	F N A	25.40	66.68	-	-	-	-	B33-625-499	BBP33	B30-R6000HF	1500	3
●	B-499	F N A	25.40	66.68	-	-	-	-	BPT-625-499	BBP12, BP-PR+	R7950	1500	3
4.0 - 50.0 ml													
▲	B-427	F N S	30.48	-	4.30	-	12.70	-	M21-1250-427	BMP21-LAB	-	1	-
▲	B-427	F N S	31.75	-	7.62	-	12.70	-	MC-1250-427	BMP51, BMP53	-	1	1
○	B-461	F N A H S L	31.75	-	7.62	-	31.75	-	MC-1250-461-AW**	BMP51, BMP53	-	1	1
▷	B-461	F N A H S L	34.93	45.72	-	-	34.93	40.00	B33-632-461*	BBP33	B30-R4300	1500	1
▷	B-461	F N A H S L	34.93	45.72	-	-	34.93	40.00	BPT-632-461*	BBP12, BP-PR+	R7950	2000	1
5.0 - 50.0 ml													
▲	B-427	F N S	38.10	-	4.30	-	12.70	-	M21-1500-427	BMP21-LAB	-	1	-
▲	B-427	F N S	38.10	-	7.62	-	12.70	-	MC-1500-427	BMP51, BMP53	-	1	1
○	B-499	F N A	48.26	-	9.10	-	-	-	M71C-1900-499	BMP71	M71-R4300	1	1

*Label is rotated 90° on liner. **AW = All White / no transparent area.

Conical / Large Tube Labels

Diagram

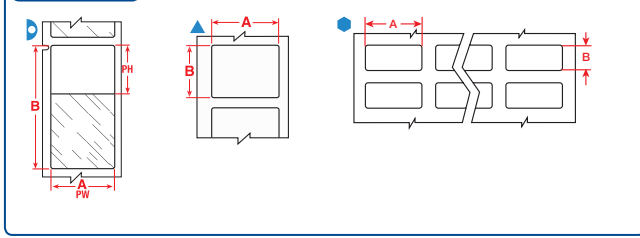

The background colours in the Order Reference column represent the material colour.

See page 38 for Brady's range of label printers.

Labels are shown per vial / tube size and in order of label width.

Diagram	Material	Special Properties	Label Width A (mm)	Label Height B (mm)	Label Length B (m)	Diameter C (mm)	Printable Area Width PW (mm)	Printable Area Height PH (mm)	Order Reference	Printer Compatibility	Printer Ribbon Series	Labels/Package	Labels per Row
12.0 - 14.0 ml													
▷	B-461	FNAHSL	38.10	95.25	-	-	38.10	31.75	M-119-461	BMP51, BMP53	-	80	1
12.0 - 24.0 ml													
▲	B-492	F N H L	25.40	48.26	-	-	-	-	M-78-492	BMP51, BMP53	-	100	1
▲	B-498	F R	38.10	12.70	-	-	-	-	BM71-29-498	BMP71	M71-R6200	5000	1
▲	B-498	F R	38.10	12.70	-	-	-	-	M71-29-498	BMP71	M71-R6200	500	1
▲	B-499	FNA	38.10	12.70	-	-	-	-	M71-29-499	BMP71	M71-R4300	500	1
▲	B-499	FNA	38.10	31.75	-	-	-	-	M-132-499	BMP51, BMP53	-	160	1
12.0 - 50.0 ml													
▷	B-461	FNAHSL	25.40	133.35	-	-	25.40	38.10	B33-139-461	BBP33	B30-R4300	650	2
▷	B-461	FNAHSL	25.40	133.35	-	-	25.40	38.10	THT-139-461-2	BBP12, BP-PR+, IP	R4300, R7950	2000	2
14.0 - 15.0 ml													
▲	B-490	F N H L	38.10	55.88	-	-	-	-	M-113-490	BMP51, BMP53	-	140	1
▷	B-461	FNAHSL	38.10	57.15	-	-	38.10	31.75	M-129-461	BMP51, BMP53	-	140	1
▷	B-427	F N S	38.10	63.50	-	-	38.10	19.05	B33-517-427	BBP33	B30-R4300	1000	2
▷	B-427	F N S	38.10	63.50	-	-	38.10	19.05	BPT-517-427	BBP12, BP-PR+	R7950	2000	2
▷	B-427	F N S	38.10	63.50	-	-	38.10	19.05	M-116-427	BMP51, BMP53	-	80	1
▲	B-490	F N H L	55.88	38.10	-	-	-	-	THT-157-490-1.5-SC	BBP12, BP-PR+	R7950	1500	1
▲	B-490	F N H L	55.88	38.10	-	-	-	-	THT-157-490-3	BBP12, BP-PR+, IP	R4300, R7950	3000	1
15.0 - 50.0 ml													
▷	B-461	FNAHSL	19.05	38.10	-	-	19.05	33.00	BPT-629-461*	BBP12, BP-PR+	R7950	2500	2
●	B-499	FNA	20.32	36.50	-	-	-	-	B33-165-499	BBP33	B30-R6000HF	2500	4
●	B-498	F R	20.32	36.50	-	-	-	-	B33-95-498	BBP33	B30-R6200	2300	3
●	B-498	F R	20.32	36.50	-	-	20.32	36.50	THT-95-498-5	BBP12, BP-PR+, IP	R4300, R7950	5000	3
●	B-499	FNA	20.32	36.50	-	-	36.50	20.32	THT-69-499-3	BBP12, BP-PR+, IP	R4900	3000	2
●	B-499	FNA	22.86	38.10	-	-	-	-	BPT-618-499	BBP12, BP-PR+	R7950	3000	3
●	B-499	FNA	25.40	36.50	-	-	-	-	B33-621-499	BBP33	B30-R6000HF	3000	3
●	B-498	F R	25.40	36.50	-	-	-	-	BPT-621-498	BBP12, BP-PR+	R7950	3000	3
●	B-499	FNA	25.40	36.50	-	-	-	-	BPT-621-499	BBP12, BP-PR+	R7950	3000	3
●	B-498	F R	25.40	36.50	-	-	36.50	25.40	THT-89-498-5	BBP12, BP-PR+, IP	R4300, R7950	5000	3
▷	B-461	FNAHSL	25.40	66.68	-	-	25.40	25.40	B33-276-461	BBP33	B30-R4300	1500	2
▷	B-461	FNAHSL	38.10	88.90	-	-	38.10	31.75	B33-134-461*	BBP33	B30-R4300	1000	1
▷	B-461	FNAHSL	38.10	88.90	-	-	38.10	31.75	THT-134-461-3*	BBP12, BP-PR+, IP	R4300, R7950	3000	1
▲	B-461	FNAHSL	48.26	25.40	-	-	48.26	25.40	B33-636-461AW**	BBP33	B30-R4300	2000	1
▲	B-461	FNAHSL	48.26	25.40	-	-	48.26	25.40	BPT-636-461-AW**	BBP12, BP-PR+	R7950	2000	1
▲	B-427	F N S	55.88	38.10	-	-	55.88	38.10	B33-640-427AW**	BBP33	B30-R4300	1500	1
▲	B-427	F N S	55.88	38.10	-	-	55.88	38.10	BPT-640-427-AW**	BBP12, BP-PR+	R7950	2000	1
▲	B-461	FNAH L	57.15	19.05	-	-	57.15	19.05	B33-642-461AW**	BBP33	B30-R4300	2000	1
▲	B-461	FNAHSL	57.15	19.05	-	-	57.15	19.05	BPT-642-461-AW**	BBP12, BP-PR+	R7950	2000	1
▲	B-427	F N S	66.68	25.40	-	-	66.68	25.40	B33-648-427AW**	BBP33	B30-R4300	1500	1
▲	B-427	F N S	66.68	25.40	-	-	66.68	25.40	BPT-648-427-AW**	BBP12, BP-PR+	R7950	2000	1
▲	B-461	FNAHSL	88.90	38.10	-	-	88.90	38.10	B33-650-461AW**	BBP33	B30-R4300	2000	1
▲	B-461	FNAHSL	88.90	38.10	-	-	88.90	38.10	BPT-650-461-AW**	BBP12, BP-PR+	R7950	2000	1

*Label is rotated 90° on liner. **AW = All White / no transparent area.

>>>

Conical / Large Tube Labels

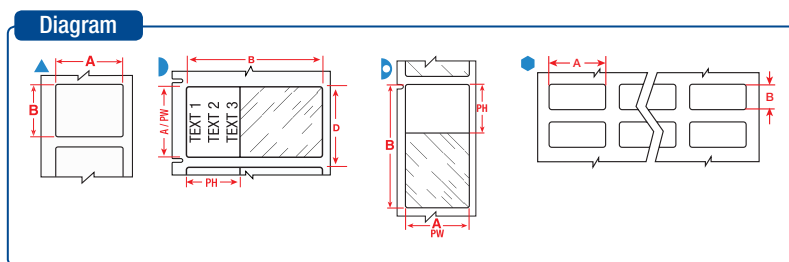

The background colours in the Order Reference column represent the material colour.

See page 38 for Brady's range of label printers.

Labels are shown per vial / tube size and in order of label width.

Diagram	Material	Special Properties	Label Width A (mm)	Label Height B (mm)	Label Length B (m)	Diameter C (mm)	Printable Area Width PW (mm)	Printable Area Height PH (mm)	Order Reference	Printer Compatibility	Printer Ribbon Series	Labels/Package	Labels per Row
50.0 ml													
	B-423	F AH	12.70	12.70	-	-	-	-	BM71-7-423	BMP71	M71-R6000HF	5000	1
	B-423	F AH	12.70	12.70	-	-	-	-	M71-7-423	BMP71	M71-R6000HF	500	1
	B-427	FN S	19.05	38.10	-	-	19.05	12.70	BM71-30-427	BMP71	M71-R4300	2500	1
	B-427	FN S	19.05	38.10	-	-	19.05	12.70	M71-30-427	BMP71	M71-R4300	250	1
	B-427	FN S	19.05	38.10	-	-	19.05	12.70	M-90-427	BMP51, BMP53	-	180	1
	B-461	FNAHSL	19.05	38.10	-	-	19.05	33.02	B33-629-461*	BBP33	B30-R4300	2500	2
	B-492	FN H L	22.86	25.40	-	-	-	-	THT-180-492-3	BBP12, BP-PR+, IP	R6400	3000	1
	B-423	F AH	25.40	4.75	-	-	-	-	M71-14-423	BMP71	M71-R6000HF	750	1
	B-423	F AH	25.40	4.75	-	-	-	-	THT-41-423-10	BBP12, BP-PR+, IP	R6000HF	10000	3
	B-423	F AH	25.40	6.35	-	-	-	-	THT-51-423-10	BBP12, BP-PR+, IP	R6000HF	10000	3
	B-423	F AH	25.40	6.99	-	-	-	-	M71-15-423	BMP71	M71-R6000HF	750	1
	B-423	F AH	25.40	12.70	-	-	-	-	M71-17-423	BMP71	M71-R6000HF	500	1
	B-492	FN H L	25.40	12.70	-	-	-	-	M71-17-492	BMP71	M71-R6400	500	1
	B-498	F R	25.40	12.70	-	-	-	-	M71-17-498	BMP71	M71-R6200	500	1
	B-492	FN H L	25.40	25.40	-	-	-	-	B33-179-492	BBP33	B30-R6400	1900	1
	B-492	FN H L	25.40	25.40	-	-	-	-	THT-179-492-2.5-SC	BBP12, BP-PR+	R6400	2500	1
	B-492	FN H L	25.40	25.40	-	-	-	-	THT-179-492-3	BBP12, BP-PR+, IP	R6400	3000	1
	B-427	FN S	25.40	38.10	-	-	25.40	12.70	BM71-31-427	BMP71	M71-R4300	2500	1
	B-427	FN S	25.40	38.10	-	-	25.40	12.70	M71-31-427	BMP71	M71-R4300	250	1
	B-461	FNAHSL	25.40	38.10	-	-	25.40	12.70	M71-31-461	BMP71	M71-R6200	250	1
	B-427	FN S	25.40	38.10	-	-	25.40	12.70	M-91-427	BMP51, BMP53	-	180	1
	B-499	FNA	25.40	48.26	-	-	-	-	M-128-499	BMP51, BMP53	-	100	1
	B-499	FNA	25.40	50.80	-	-	-	-	B33-137-499	BBP33	B30-R6000HF	1100	1
	B-423	F AH	25.40	50.80	-	-	-	-	BM71-20-423	BMP71	M71-R6000HF	1000	1
	B-423	F AH	25.40	50.80	-	-	-	-	M71-20-423	BMP71	M71-R6000HF	100	1
	B-427	FN S	25.40	50.80	-	-	25.40	50.80	THT-137-427-3-AW**	BBP12, BP-PR+, IP	R4300, R7950	3000	1
	B-499	FNA	25.40	63.50	-	-	-	-	M71-21-499	BMP71	M71-R4300	100	1
	B-423	F AH	25.40	76.20	-	-	-	-	M71-22-423	BMP71	M71-R6000HF	100	1
	B-499	FNA	38.10	19.05	-	-	-	-	B33-136-499	BBP33	B30-R6000HF	1500	1
	B-499	FNA	38.10	19.05	-	-	-	-	M71-30-499	BMP71	M71-R4300	250	1
	B-499	FNA	38.10	19.05	-	-	-	-	THT-136-499-1.5-SC	BBP12, BP-PR+	R7950	1500	1
	B-499	FNA	38.10	19.05	-	-	-	-	THT-136-499-3	BBP12, BP-PR+, IP	R4900	3000	1
	B-427	FN S	38.10	19.05	-	-	38.10	19.05	B33-135-427AW**	BBP33	B30-R4300	1500	1
	B-427	FN S	38.10	19.05	-	-	38.10	19.05	M71-30-427-AW**	BMP71	M71-R4300	250	1
	B-427	FN S	38.10	19.05	-	-	38.10	19.05	THT-135-427-3-AW**	BBP12, BP-PR+, IP	R4300, R7950	3000	1
	B-423	F AH	38.10	25.40	-	-	-	-	M71-31-423	BMP71	M71-R6000HF	250	1
	B-498	F R	38.10	25.40	-	-	-	-	M71-31-498	BMP71	M71-R6200	250	1
	B-499	FNA	38.10	25.40	-	-	-	-	M71-31-499	BMP71	M71-R4300	250	1
	B-490	FN H L	38.10	98.42	-	-	-	-	M-114-490	BMP51, BMP53	-	80	1
	B-490	FN H L	50.80	6.35	-	-	-	-	B33-151-490	BBP33	B30-R4300	2500	1
	B-499	FNA	50.80	25.40	-	-	-	-	THT-137-499-1.5-SC	BBP12, BP-PR+	R7950	1500	1
	B-499	FNA	50.80	25.40	-	-	-	-	THT-137-499-3	BBP12, BP-PR+, IP	R4900	3000	1
	B-427	FN S	50.80	25.40	-	-	50.80	25.40	B33-137-427AW**	BBP33	B30-R4300	1500	1
	B-490	FN H L	95.25	38.10	-	-	-	-	THT-158-490-1.5-SC	BBP12, BP-PR+	R7950	1500	1
	B-490	FN H L	95.25	38.10	-	-	-	-	THT-158-490-3	BBP12, BP-PR+, IP	R4300, R7950	3000	1

*Label is rotated 90° on liner. **AW = All White / no transparent area.

SLIDE LABELS

Brady offers labels specifically designed to identify slides and to resist exposure to harsh chemicals during the slide staining process. They perform well in the hematoxylin and eosin slide staining process and offer superior chemical resistance also useful in other laboratory contexts.

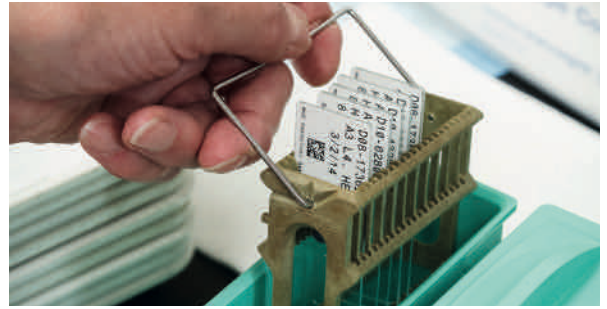

Diagram

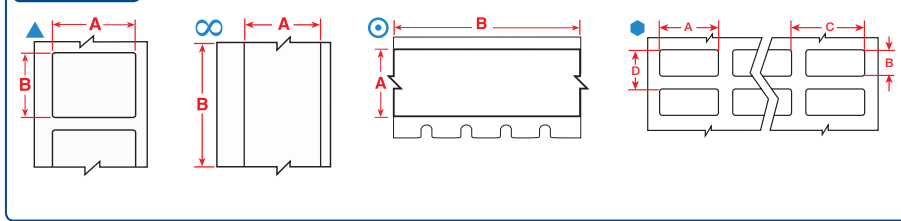

- F** Freezer environment
- N** Liquid nitrogen environment
- A** Autoclave environment
- H** Hot water bath (100°C)
- S** Self-laminating label
- L** Low-profile (extremely thin) label
- R** Removable

Labels are shown in order of label width.

The background colours in the Order Reference column represent the material colour.

See page 38 for Brady's range of label printers.

Diagram	Material	Special Properties	Label Width A (mm)	Label Height B (mm)	Label Length B (m)	Order Reference	Printer Compatibility	Printer Ribbon Series	Labels/Package	Labels per Row
▲	B-488	F A	6.35	48.26	–	M-81-488	BMP51, BMP53	–	160	1
⊙	B-488	F A	9.53	–	6.40	M21-375-488	BMP21-LAB	–	1	1
⊙	B-488	F A	12.70	–	6.40	M21-500-488	BMP21-LAB	–	1	1
⊙	B-488	F A	19.05	–	6.40	M21-750-488	BMP21-LAB	–	1	1
▲	B-488	F A	19.05	22.86	–	M71-80-488	BMP71	M71-R4300	250	1
▲	B-481	F H	22.86	9.53	–	B33-195-481	BBP33	B30-R6400	3000	1
▲	B-481	F H	22.86	9.53	–	THT-195-481-3	BBP12, BP-PR+, IP	R6400	3000	1
▲	B-481	F H	22.86	19.05	–	B33-194-481	BBP33	B30-R6400	2000	1
●	B-488	F A	22.86	19.05	–	B33-616-488	BBP33	B30-R4300	3000	3
●	B-488	F A	22.86	19.05	–	BPT-616-488	BBP12, BP-PR+	R7950	3000	3
▲	B-481	F H	22.86	19.05	–	BPT-194-481	BBP12, BP-PR+	R6400	2500	1
▲	B-481	F H	22.86	19.05	–	M-194-481	BMP51, BMP53	–	320	1
▲	B-481	F H	22.86	19.05	–	THT-194-481-3	BBP12, BP-PR+, IP	R6400	3000	1
●	B-488	F A	22.86	19.05	–	THT-140-488-3	BBP12, BP-PR+, IP	R4300, R7950	3000	2
●	B-488	F A	22.86	19.05	–	THT-140-488-1.5-SC	BBP12, BP-PR+	R7950	1500	2
●	B-488	F A	22.86	22.86	–	B33-617-488	BBP33	B30-R4300	3000	3
●	B-488	F A	22.86	22.86	–	BPT-617-488	BBP12, BP-PR+	R7950	3000	3
▲	B-481	F H	22.86	22.86	–	BPT-164-481	BBP12, BP-PR+	R6400	2500	1
▲	B-481	F H	22.86	22.86	–	M-97-481	BMP51, BMP53	–	280	1
▲	B-488	F A	22.86	22.86	–	M-97-488	BMP51, BMP53	–	180	1
▲	B-481	F H	22.86	22.86	–	M71-97-481	BMP71	M71-R6400	250	1
▲	B-488	F A	22.86	22.86	–	M71-97-488	BMP71	M71-R4300	250	1
●	B-481	F H	22.86	22.86	–	THT-207-481-2.5-SC	BBP12, BP-PR+	R6400	2500	4
▲	B-481	F H	22.86	22.86	–	THT-164-481-3	BBP12, BP-PR+, IP	R6400	3000	1
▲	B-488	F A	22.86	22.86	–	THT-164-488-1	BBP12, BP-PR+, IP	R4300, R7950	1000	1
●	B-481	F H	22.86	22.86	–	THT-141-481-3	BBP12, BP-PR+, IP	R6400	3000	2
●	B-488	F A	22.86	22.86	–	THT-141-488-3	BBP12, BP-PR+, IP	R4300, R7950	3000	2
●	B-481	F H	22.90	22.90	–	THT-141-481-1.5-SC	BBP12, BP-PR+	R6400	1500	2
▲	B-481	F H	25.40	9.53	–	M-195-481	BMP51, BMP53	–	320	1
▲	B-488	F A	48.26	6.35	–	B33-635-488	BBP33	B30-R4300	2000	1
▲	B-488	F A	50.80	6.35	–	THT-15-488-2.5	BBP12, BP-PR+, IP	R7950	2500	1
▲	B-481	F H	63.50	5.08	–	THT-142-481-2.5	BBP12, BP-PR+, IP	R6400	2500	1
▲	B-481	F H	63.50	5.08	–	THT-142-481-2.5-SC	BBP12, BP-PR+	R6400	2500	1

Tissue Cassette Labels



TISSUE CASSETTE LABELS

Specifically designed to identify tissue cassettes, Brady's B-482 label withstands a temperature range from -80°C to 121°C and offers superior resistance to chemicals used in tissue processing enabling it to retain barcode legibility. The label must be used in combination with Brady's BSP™31 Label Attachment System for pre-process tissue cassette identification and complements the use of StainerBondz slide labels as part of a complete histology process.

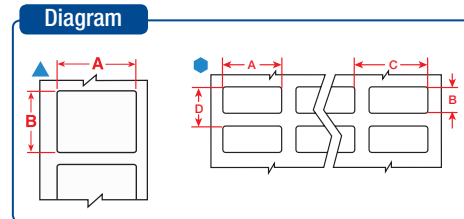

- F** Freezer environment
- N** Liquid nitrogen environment
- A** Autoclave environment
- H** Hot water bath (100°C)
- S** Self-laminating label
- L** Low-profile (extremely thin) label
- R** Removable

Labels are shown in order of label width.

The background colours in the Order Reference column represent the material colour.

See page 38 for Brady's range of label printers.

Diagram	Material	Special Properties	Label Width A (mm)	Label Height B (mm)	Order Reference	Printer Compatibility	Printer Ribbon Series	Labels/Package	Labels per Row
▲	B-482	F H	26.67	6.35	B33-199-482	BBP33	B30-R6400	3000	1
▲	B-482	F H	26.67	6.35	M-127-482	BMP51, BMP53	-	360	1
▲	B-482	F H	26.67	6.35	THT-199-482-3	BBP12, BP-PR Plus, IP	R6400	3000	1
▲	B-482	F H	26.67	6.35	THT-199-482-3-SC	BBP12, BP-PR Plus	R6400	3000	1
▲	B-482	F H	26.67	7.95	B33-213-482	BBP33	B30-R6400	3000	1
▲	B-482	F H	26.67	7.95	THT-213-482-3	BBP12, BP-PR Plus, IP	R6400	3000	1
▲	B-482	F H	26.67	7.95	THT-213-482-3-SC	BBP12, BP-PR Plus, IP	R6400	3000	1



Specimen Labelling Solution for Histology and Anatomic Pathology

As part of Brady's complete laboratory labelling solution, our combination of the B-482 Tissue Cassette label and the BSP™31 Label Attachment System, **ensures your specimen will stick throughout processing, embedding and sectioning.** See page 47 for more information on the BSP31.



B-498 Re-Identify Tissue Cassettes Labels

Tissue cassettes are often re-identified when labs collect samples from various biorepositories. Typically, each laboratory has its own unique way of identifying samples, which creates a need to re-identify samples in a common way.

Brady B-498 post-process labels offer customers the optimal way to organise these specimens and conduct further studies. These labels can be applied directly onto the cassettes, on pure paraffin wax and on top of another label or identifier.

This is not the same as Brady's B-482 tissue cassette solution. **B-498 Re-identify labels are applied after processing and are never used with the BSP31 label attachment system.**

Diagram	Material	Special Properties	Label Width A (mm)	Label Height B (mm)	Order Reference	Printer Compatibility	Printer Ribbon Series	Labels/Package	Labels per Row
●	B-498	F R	19.05	6.35	B33-1-498	BBP33	B30-R6200	5000	4
▲	B-498	F R	19.05	6.35	M71-10-498	BMP71	M71-R6200	750	1
▲	B-498	F R	19.05	6.35	THT-252-498-3	BBP12, BP-PR Plus, IP	R4300, R7950	3000	1
▲	B-498	F R	19.05	6.35	THT-252-498-3-SC	BBP12, BP-PR Plus	R7950	3000	1
●	B-498	F R	19.05	6.35	THT-1-498-10	BBP12, BP-PR Plus, IP	R4300, R7950	10000	4
▲	B-498	F R	19.05	12.70	M-11-498	BMP51, BMP53	-	220	1
▲	B-498	F R	19.05	19.05	THT-254-498-3	BBP12, BP-PR Plus, IP	R4300, R7950	3000	1
▲	B-498	F R	19.05	19.05	THT-254-498-1.5-SC	BBP12, BP-PR Plus	R7950	1500	1
▲	B-498	F R	25.40	4.75	THT-253-498-3	BBP12, BP-PR Plus, IP	R4300, R7950	3000	1
▲	B-498	F R	25.40	4.75	THT-253-498-3-SC	BBP12, BP-PR Plus	R7950	3000	1

- F** Freezer environment
- N** Liquid nitrogen environment
- A** Autoclave environment
- H** Hot water bath (100°C)
- S** Self-laminating label
- L** Low-profile (extremely thin) label
- R** Removable

STRAW AND ROD LABELS

Brady offers a range of labels designed to fit the small surface area of straws and rods and will withstand long-term storage.



Diagram

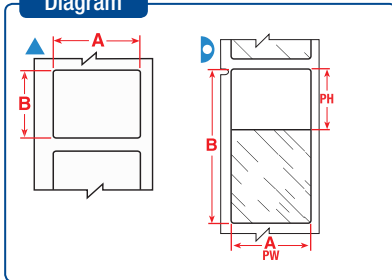

Labels are shown per straw size and in order of label width.

The background colours in the Order Reference column represent the material colour.

See page 38 for Brady's range of label printers.

Diagram	Material	Special Properties	Label Width A (mm)	Label Height B (mm)	Printable Area Width PW (mm)	Printable Area Height PH (mm)	Order Reference	Printer Compatibility	Printer Ribbon Series	Labels/Package	Labels per Row
0.25 ml Straw											
▲	B-427	FN S	20.00	20.00	20.00	20.00	BPTLAB-35-427-YL	BBP12, BP-PR+	R7950	1000	1
▷	B-427	FN S	25.40	25.40	25.40	9.53	B33-116-427	BBP33	B30-R4300	2500	2
▷	B-427	FN S	25.40	25.40	25.40	9.53	B33-211-427	BBP33	B30-R4300	3000	3
▷	B-427	FN S	25.40	25.40	25.40	9.53	BM71-19-427	BMP71	M71-R4300	2500	1
▷	B-427	FN S	25.40	25.40	25.40	9.53	BPT-211-427	BBP12, BP-PR+	R7950	3000	3
▷	B-427	FN S	25.40	25.40	25.40	9.53	M-49-427	BMP51, BMP53	-	260	1
▷	B-427	FN S	25.40	25.40	25.40	9.53	M71-19-427	BMP71	M71-R4300	250	1
▷	B-461	FN A H S L	25.40	25.40	25.40	9.53	M71-19-461	BMP71	M71-R4300	250	1
▷	B-427	FN S	25.40	25.40	25.40	9.53	M71-19-427-YL	BMP71	M71-R4300	250	1
▷	B-427	FN S	25.40	25.40	25.40	9.53	THT-116-427-5	BBP12, BP-PR+, IP	R4300, R7950	5000	2
▷	B-427	FN S	44.45	25.40	44.45	9.53	B33-120-427	BBP33	B30-R4300	1250	1
▷	B-427	FN S	44.45	25.40	44.45	9.53	M-133-427	BMP51, BMP53	-	140	1
▷	B-427	FN S	44.45	38.10	44.45	12.70	B33-121-427	BBP33	B30-R4300	1000	1
▷	B-427	FN S	44.45	38.10	44.45	12.70	M71-88-427	BMP71	M71-R4300	250	1
0.50 ml Straw											
▷	B-427	FN S	25.40	63.50	25.40	19.05	BM71-21-427	BMP71	M71-R4300	1000	1
▷	B-427	FN S	25.40	63.50	25.40	19.05	B33-511-427	BBP33	B30-R4300	1500	3
▷	B-427	FN S	25.40	63.50	25.40	19.05	BPT-511-427	BBP12, BP-PR+	R7950	3000	3
▷	B-427	FN S	25.40	63.50	25.40	19.05	M-51-427	BMP51, BMP53	-	110	1
▷	B-427	FN S	25.40	63.50	25.40	19.05	M71-21-427	BMP71	M71-R4300	100	1
▷	B-427	FN S	25.40	63.50	25.40	19.05	M71-21-427-YL	BMP71	M71-R4300	100	1
▷	B-427	FN S	44.45	38.10	44.45	12.70	M-134-427	BMP51, BMP53	-	140	1
Straw Rod											
▲	B-427	FN S	27.94	6.35	27.94	6.35	M-135-427-AW**	BMP51, BMP53	-	240	1
▷	B-461	FN A H S L	6.35	27.94	6.35	22.00	BPT-627-461*	BBP12, BP-PR+	R7950	1000	1

*Label is rotated 90° on liner. **AW = All White / no transparent area.

Part number explanation

Most Brady references for printable labels follow the same three-part format: The first code indicates the technology, the second part is a number indicating the label size (where applicable) and the third part indicates the Brady material (where applicable).

M71-73-461

Technology: M71
Label size code: 73
Material (B-number): 461

Well Plate Labels

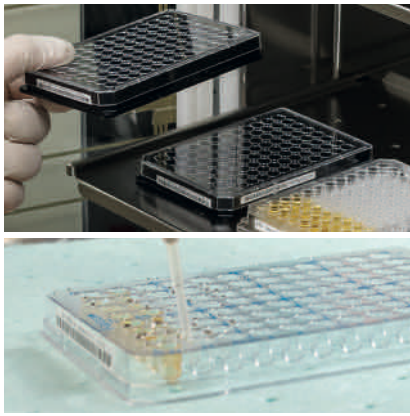

WELL PLATE LABELS

When total tracking of all sample collections is required then Brady has a solution for Well plate identification. Our well plate labels guarantee crystal clear text and barcoding for most lab environments.

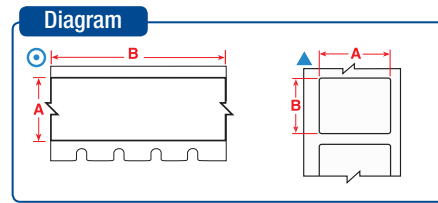

- F** Freezer environment
- N** Liquid nitrogen environment
- A** Autoclave environment
- H** Hot water bath (100°C)
- S** Self-laminating label
- L** Low-profile (extremely thin) label
- R** Removable

Labels are shown in order of label width.

The background colours in the Order Reference column represent the material colour.

See page 38 for Brady's range of label printers.

Diagram	Material	Special Properties	Label Width A (mm)	Label Height B (mm)	Label Length B (m)	Order Reference	Printer Compatibility	Printer Ribbon Series	Labels/Package	Labels per Row
⊙	B-423	F A H	6.35	–	6.40	M21-250-423	BMP21-LAB	–	1	1
⊙	B-430	F A H	6.35	–	6.40	M21-250-430	BMP21-LAB	–	1	1
⊙	B-595	F	6.35	–	6.40	M21-250-595-WT	BMP21-LAB	–	1	1
⊙	B-430	F A H	6.35	–	6.40	M21-250-430-WT-CL	BMP21-LAB	–	1	1
⊙	B-595	F	6.35	–	6.40	M21-250-595-YL	BMP21-LAB	–	1	1
▲	B-488	F A	6.35	48.26	–	M-81-488	BMP51, BMP53	–	160	1
▲	B-423	F A H	6.35	50.80	–	M71-2-423	BMP71	M71-R6000HF	100	1
⊙	B-499	F N A	9.53	–	4.88	M21-375-499	BMP21-LAB	–	1	1
⊙	B-499	F N A	9.53	–	4.88	MC-375-499	BMP51, BMP53	–	1	1
⊙	B-423	F A H	9.53	–	6.40	M21-375-423	BMP21-LAB	–	1	1
⊙	B-430	F A H	9.53	–	6.40	M21-375-430	BMP21-LAB	–	1	1
⊙	B-488	F A	9.53	–	6.40	M21-375-488	BMP21-LAB	–	1	1
⊙	B-7425	F N A H	9.53	–	6.40	M21-375-7425	BMP21-LAB	–	1	1
⊙	B-595	F	9.53	–	6.40	M21-375-595-BK	BMP21-LAB	–	1	1
⊙	B-595	F	9.53	–	6.40	M21-375-595-BL	BMP21-LAB	–	1	1
⊙	B-595	F	9.53	–	6.40	M21-375-595-GN	BMP21-LAB	–	1	1
⊙	B-595	F	9.53	–	6.40	M21-375-595-OR	BMP21-LAB	–	1	1
⊙	B-595	F	9.53	–	6.40	M21-375-595-RD	BMP21-LAB	–	1	1
⊙	B-595	F	9.53	–	6.40	M21-375-595-WT	BMP21-LAB	–	1	1
⊙	B-430	F A H	9.53	–	6.40	M21-375-430-WT-CL	BMP21-LAB	–	1	1
⊙	B-595	F	9.53	–	6.40	M21-375-595-YL	BMP21-LAB	–	1	1
⊙	B-595	F	9.53	–	7.62	MC-375-595-WT-BK	BMP51, BMP53	–	1	1
⊙	B-595	F	9.53	–	7.62	MC-375-595-YL-BK	BMP51, BMP53	–	1	1
⊙	B-430	F A H	9.53	–	15.24	M71C-375-430	BMP71	M71-R6000HF	1	1
⊙	B-499	F N A	12.70	–	4.88	M21-500-499	BMP21-LAB	–	1	1
⊙	B-499	F N A	12.70	–	4.88	MC-500-499	BMP51, BMP53	–	1	1
⊙	B-595	F	12.70	–	6.10	MC-500-595-CL-BK	BMP51, BMP53	–	1	1
⊙	B-595	F	12.70	–	6.10	MC-500-595-CL-WT	BMP51, BMP53	–	1	1
⊙	B-423	F A H	12.70	–	6.40	M21-500-423	BMP21-LAB	–	1	1
⊙	B-430	F A H	12.70	–	6.40	M21-500-430	BMP21-LAB	–	1	1
⊙	B-488	F A	12.70	–	6.40	M21-500-488	BMP21-LAB	–	1	1
⊙	B-7425	F N A H	12.70	–	6.40	M21-500-7425	BMP21-LAB	–	1	1
⊙	B-595	F	12.70	–	6.40	M21-500-595-BK	BMP21-LAB	–	1	1
⊙	B-595	F	12.70	–	6.40	M21-500-595-BL	BMP21-LAB	–	1	1
⊙	B-595	F	12.70	–	6.40	M21-500-595-GN	BMP21-LAB	–	1	1
⊙	B-595	F	12.70	–	6.40	M21-500-595-OR	BMP21-LAB	–	1	1
⊙	B-595	F	12.70	–	6.40	M21-500-595-RD	BMP21-LAB	–	1	1
⊙	B-595	F	12.70	–	6.40	M21-500-595-WT	BMP21-LAB	–	1	1
⊙	B-430	F A H	12.70	–	6.40	M21-500-430-WT-CL	BMP21-LAB	–	1	1
⊙	B-595	F	12.70	–	6.40	M21-500-595-YL	BMP21-LAB	–	1	1
⊙	B-595	F	12.70	–	7.62	MC-500-595-BK-WT	BMP51, BMP53	–	1	1
⊙	B-595	F	12.70	–	7.62	MC-500-595-BL-WT	BMP51, BMP53	–	1	1
⊙	B-595	F	12.70	–	7.62	MC-500-595-GN-WT	BMP51, BMP53	–	1	1
⊙	B-595	F	12.70	–	7.62	MC-500-595-OR-BK	BMP51, BMP53	–	1	1
⊙	B-595	F	12.70	–	7.62	MC-500-595-RD-WT	BMP51, BMP53	–	1	1
⊙	B-595	F	12.70	–	7.62	MC-500-595-WT-BK	BMP51, BMP53	–	1	1
⊙	B-595	F	12.70	–	7.62	MC-500-595-WT-RD	BMP51, BMP53	–	1	1
⊙	B-595	F	12.70	–	7.62	MC-500-595-YL-BK	BMP51, BMP53	–	1	1
⊙	B-499	F N A	12.70	–	9.10	M71C-500-499	BMP71	M71-R4300	1	1
⊙	B-430	F A H	12.70	–	15.24	M71C-500-430	BMP71	M71-R6000HF	1	1
⊙	B-595	F	12.70	–	15.24	M71C-500-595-BK	BMP71	M71-R6000HF	1	1
⊙	B-595	F	12.70	–	15.24	M71C-500-595-BL	BMP71	M71-R6000HF	1	1
⊙	B-595	F	12.70	–	15.24	M71C-500-595-CL	BMP71	M71-R6000HF	1	1

Diagram

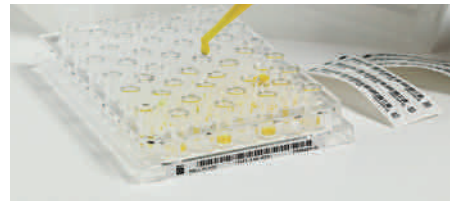
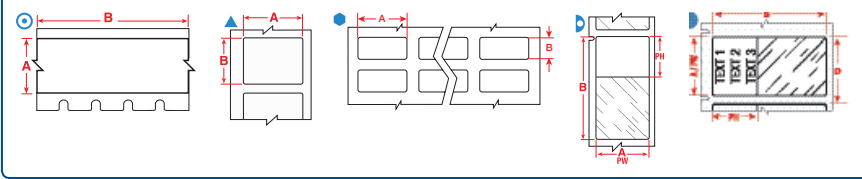
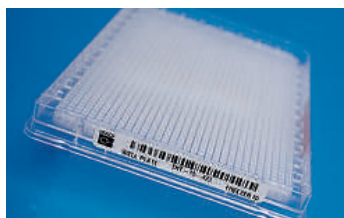
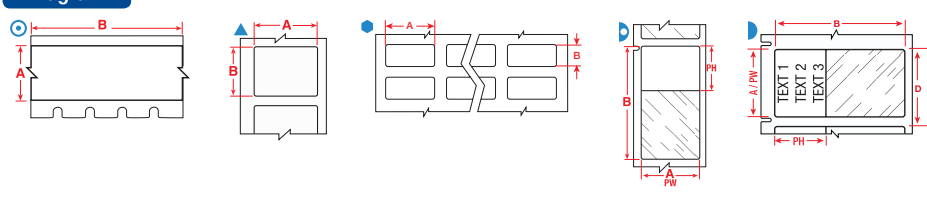

Diagram	Material	Special Properties	Label Width A (mm)	Label Height B (mm)	Label Length B (m)	Order Reference	Printer Compatibility	Printer Ribbon Series	Labels/ Package	Labels per Row
⊙	B-595	F	12.70	–	15.24	M71C-500-595-GN	BMP71	M71-R6000HF	1	1
⊙	B-595	F	12.70	–	15.24	M71C-500-595-OR	BMP71	M71-R6000HF	1	1
⊙	B-595	F	12.70	–	15.24	M71C-500-595-RD	BMP71	M71-R6000HF	1	1
⊙	B-595	F	12.70	–	15.24	M71C-500-595-WT	BMP71	M71-R6000HF	1	1
⊙	B-595	F	12.70	–	15.24	M71C-500-595-YL	BMP71	M71-R6000HF	1	1
⊙	B-595	F	12.70	–	30.40	B30C-500-595-BK	BBP33	B30-R10000-WT	1	1
⊙	B-595	F	12.70	–	30.40	B30C-500-595-BL	BBP33	B30-R10000-WT	1	1
⊙	B-595	F	12.70	–	30.40	B30C-500-595-CL	BBP33	B30-R10000	1	1
⊙	B-595	F	12.70	–	30.40	B30C-500-595-GN	BBP33	B30-R10000-WT	1	1
⊙	B-595	F	12.70	–	30.40	B30C-500-595-OR	BBP33	B30-R10000	1	1
⊙	B-595	F	12.70	–	30.40	B30C-500-595-RD	BBP33	B30-R10000-WT	1	1
⊙	B-595	F	12.70	–	30.40	B30C-500-595-WT	BBP33	B30-R10000	1	1
⊙	B-595	F	12.70	–	30.40	B30C-500-595-YL	BBP33	B30-R10000	1	1
▲	B-423	F AH	12.70	12.70	–	BM71-7-423	BMP71	M71-R6000HF	5000	1
▲	B-423	F AH	12.70	12.70	–	M71-7-423	BMP71	M71-R6000HF	500	1
⊙	B-499	F NA	19.05	–	4.88	M21-750-499	BMP21-LAB	–	1	1
⊙	B-499	F NA	19.05	–	4.88	MC-750-499	BMP51, BMP53	–	1	1
⊙	B-595	F	19.05	–	6.10	MC-750-595-CL-BK	BMP51, BMP53	–	1	1
⊙	B-595	F	19.05	–	6.10	MC-750-595-CL-WT	BMP51, BMP53	–	1	1
⊙	B-423	F AH	19.05	–	6.40	M21-750-423	BMP21-LAB	–	1	1
⊙	B-430	F AH	19.05	–	6.40	M21-750-430	BMP21-LAB	–	1	1
⊙	B-488	F A	19.05	–	6.40	M21-750-488	BMP21-LAB	–	1	1
⊙	B-7425	F NA AH	19.05	–	6.40	M21-750-7425	BMP21-LAB	–	1	1
⊙	B-595	F	19.05	–	6.40	M21-750-595-BK	BMP21-LAB	–	1	1
⊙	B-595	F	19.05	–	6.40	M21-750-595-BL	BMP21-LAB	–	1	1
⊙	B-595	F	19.05	–	6.40	M21-750-595-GN	BMP21-LAB	–	1	1
⊙	B-595	F	19.05	–	6.40	M21-750-595-OR	BMP21-LAB	–	1	1
⊙	B-595	F	19.05	–	6.40	M21-750-595-RD	BMP21-LAB	–	1	1
⊙	B-595	F	19.05	–	6.40	M21-750-595-WT	BMP21-LAB	–	1	1
⊙	B-430	F AH	19.05	–	6.40	M21-750-430-WT-CL	BMP21-LAB	–	1	1
⊙	B-595	F	19.05	–	6.40	M21-750-595-YL	BMP21-LAB	–	1	1
⊙	B-595	F	19.05	–	7.62	MC-750-595-BK-WT	BMP51, BMP53	–	1	1
⊙	B-595	F	19.05	–	7.62	MC-750-595-BL-WT	BMP51, BMP53	–	1	1
⊙	B-595	F	19.05	–	7.62	MC-750-595-GN-WT	BMP51, BMP53	–	1	1
⊙	B-595	F	19.05	–	7.62	MC-750-595-OR-BK	BMP51, BMP53	–	1	1
⊙	B-595	F	19.05	–	7.62	MC-750-595-RD-WT	BMP51, BMP53	–	1	1
⊙	B-595	F	19.05	–	7.62	MC-750-595-WT-BK	BMP51, BMP53	–	1	1
⊙	B-595	F	19.05	–	7.62	MC-750-595-WT-RD	BMP51, BMP53	–	1	1
⊙	B-595	F	19.05	–	7.62	MC-750-595-YL-BK	BMP51, BMP53	–	1	1
●	B-8423	F A	19.05	6.35	–	BPT1-8423-2.5	BBP12, BP-PR+	R6000	2500	5
▷	B-427	F N S	19.05	38.10	–	BM71-30-427	BMP71	M71-R4300	2500	1
▷	B-427	F N S	19.05	38.10	–	M-90-427	BMP51, BMP53	–	180	1
▷	B-427	F N S	19.05	38.10	–	M71-30-427	BMP71	M71-R4300	250	1
●	B-498	F R	20.32	36.50	–	B33-95-498	BBP33	B30-R6200	2300	3
●	B-498	F R	20.32	36.50	–	THT-95-498-5	BBP12, BP-PR+, IP	R4300, R7950	5000	3
▲	B-499	F NA	22.86	12.70	–	M71-84-499	BMP71	M71-R4300	500	1
●	B-488	F A	22.86	19.05	–	B33-616-488	BBP33	B30-R4300	3000	3
●	B-488	F A	22.86	22.86	–	B33-617-488	BBP33	B30-R4300	3000	3
⊙	B-499	F NA	25.40	–	4.88	MC-1000-499	BMP51, BMP53	–	1	1
⊙	B-595	F	25.40	–	6.10	MC1-1000-595-CL-BK	BMP51, BMP53	–	1	1
⊙	B-595	F	25.40	–	6.10	MC1-1000-595-CL-WT	BMP51, BMP53	–	1	1
⊙	B-595	F	25.40	–	7.62	MC1-1000-595-BK-WT	BMP51, BMP53	–	1	1
⊙	B-595	F	25.40	–	7.62	MC1-1000-595-BL-WT	BMP51, BMP53	–	1	1
⊙	B-595	F	25.40	–	7.62	MC1-1000-595-GN-WT	BMP51, BMP53	–	1	1
⊙	B-595	F	25.40	–	7.62	MC1-1000-595-OR-BK	BMP51, BMP53	–	1	1
⊙	B-595	F	25.40	–	7.62	MC1-1000-595-RD-WT	BMP51, BMP53	–	1	1
⊙	B-595	F	25.40	–	7.62	MC1-1000-595-WT-BK	BMP51, BMP53	–	1	1
⊙	B-595	F	25.40	–	7.62	MC1-1000-595-WT-RD	BMP51, BMP53	–	1	1
⊙	B-595	F	25.40	–	7.62	MC1-1000-595-YL-BK	BMP51, BMP53	–	1	1
⊙	B-499	F NA	25.40	–	9.10	M71C-1000-499	BMP71	M71-R4300	1	1
⊙	B-430	F AH	25.40	–	15.24	M71C-1000-430	BMP71	M71-R6000HF	1	1
⊙	B-595	F	25.40	–	15.24	M71C-1000-595-BK	BMP71	M71-R6000HF	1	1

Well Plate Labels



Diagram



Labels are shown in order of label width.

The background colours in the Order Reference column represent the material colour.

See page 38 for Brady's range of label printers.

Diagram	Material	Special Properties	Label Width A (mm)	Label Height B (mm)	Label Length B (m)	Order Reference	Printer Compatibility	Printer Ribbon Series	Labels/ Package	Labels per Row
⊙	B-595	F	25.40	–	15.24	M71C-1000-595-BL	BMP71	M71-R4400-WT	1	1
⊙	B-595	F	25.40	–	15.24	M71C-1000-595-CL	BMP71	M71-R6000HF	1	1
⊙	B-595	F	25.40	–	15.24	M71C-1000-595-GN	BMP71	M71-R4400-WT	1	1
⊙	B-595	F	25.40	–	15.24	M71C-1000-595-OR	BMP71	M71-R6000HF	1	1
⊙	B-595	F	25.40	–	15.24	M71C-1000-595-RD	BMP71	M71-R4400-WT	1	1
⊙	B-595	F	25.40	–	15.24	M71C-1000-595-WT	BMP71	M71-R6000HF	1	1
⊙	B-595	F	25.40	–	15.24	M71C-1000-595-YL	BMP71	M71-R6000HF	1	1
▲	B-423	F AH	25.40	4.75	–	M71-14-423	BMP71	M71-R6000HF	750	1
●	B-423	F AH	25.40	4.75	–	TH1-41-423-10	BBP12, BP-PR+, IP	R6000HF	10000	3
▲	B-423	F AH	25.40	6.35	–	TH1-51-423-10	BBP12, BP-PR+, IP	R6000HF	10000	3
▲	B-423	F AH	25.40	6.99	–	M71-15-423	BMP71	M71-R6000HF	750	1
●	B-499	F NA	25.40	9.53	–	B33-152-499	BBP33	B30-R6000HF	1500	2
●	B-499	F NA	25.40	9.53	–	TH1-152-499-3	BBP12, BP-PR+, IP	R4900	3000	2
●	B-499	F NA	25.40	9.53	–	TH1-152-499-1.5-SC	BBP12, BP-PR+	R7950	1500	2
▲	B-425	F	25.40	9.98	–	TH1-30-425-10	BBP12, BP-PR+, IP	R6400	10000	3
▲	B-432	F A	25.40	12.70	–	M-17-432-CL-BK	BMP51, BMP53	–	280	1
▲	B-423	F AH	25.40	12.70	–	M71-17-423	BMP71	M71-R6000HF	500	1
▲	B-430	F AH	25.40	12.70	–	M71-17-430	BMP71	M71-R6000HF	500	1
▲	B-498	F R	25.40	12.70	–	M71-17-498	BMP71	M71-R6200	500	1
●	B-430	F AH	25.40	12.70	–	TH1-39-430-10	BBP12, BP-PR+, IP	R6000HF	10000	3
●	B-498	F R	25.40	36.50	–	BPT-621-498	BBP12, BP-PR+	R7950	3000	3
●	B-498	F R	25.40	36.50	–	TH1-89-498-5	BBP12, BP-PR+, IP	R4300, R7950	5000	3
▷	B-427	F N S	25.40	38.10	–	BM71-31-427	BMP71	M71-R4300	2500	1
▷	B-427	F N S	25.40	38.10	–	M-91-427	BMP51, BMP53	–	180	1
▷	B-427	F N S	25.40	38.10	–	M71-31-427	BMP71	M71-R4300	250	1
▷	B-461	F NAHSL	25.40	38.10	–	M71-31-461	BMP71	M71-R6200	250	1
▲	B-423	F AH	25.40	50.80	–	BM71-20-423	BMP71	M71-R6000HF	1000	1
▲	B-423	F AH	25.40	50.80	–	M71-20-423	BMP71	M71-R6000HF	100	1
▲	B-423	F AH	25.40	76.20	–	M71-22-423	BMP71	M71-R6000HF	100	1
●	B-423	F AH	27.94	9.65	–	TH1-31-423-10	BBP12, BP-PR+, IP	R6000HF	10000	2
▲	B-498	F R	38.10	12.70	–	BM71-29-498	BMP71	M71-R6200	5000	1
▲	B-498	F R	38.10	12.70	–	M71-29-498	BMP71	M71-R6200	500	1
▲	B-499	F NA	38.10	12.70	–	M71-29-499	BMP71	M71-R4300	500	1
●	B-423	F AH	38.10	12.70	–	TH1-37-423-10	BBP12, BP-PR+, IP	R6000HF	10000	2
▲	B-499	F NA	38.10	19.05	–	B33-136-499	BBP33	B30-R6000HF	1500	1
▲	B-8423	F A	38.10	19.05	–	BPT-6-8423-2.5	BBP12, BP-PR+	R6000HF	2500	2
▲	B-499	F NA	38.10	19.05	–	M71-30-499	BMP71	M71-R4300	250	1
▲	B-427	F N S	38.10	19.05	–	M71-30-427-AW**	BMP71	M71-R4300	250	1
▲	B-499	F NA	38.10	19.05	–	TH1-136-499-3	BBP12, BP-PR+, IP	R4900	3000	1
▲	B-499	F NA	38.10	19.05	–	TH1-136-499-1.5-SC	BBP12, BP-PR+	R7950	1500	1
▲	B-423	F AH	38.10	25.40	–	M71-31-423	BMP71	M71-R6000HF	250	1
▲	B-498	F R	38.10	25.40	–	M71-31-498	BMP71	M71-R6200	250	1
▲	B-499	F NA	38.10	25.40	–	M71-31-499	BMP71	M71-R4300	250	1
⊙	B-499	F NA	48.26	–	9.10	M71C-1900-499	BMP71	M71-R4300	1	1
⊙	B-430	F AH	48.26	–	15.24	M71C-1900-430	BMP71	M71-R6000HF	1	1
▲	B-488	F A	48.26	6.35	–	B33-635-488	BBP33	B30-R4300	2000	1
▲	B-488	F A	48.26	6.35	–	BPT-635-488	BBP12, BP-PR+	R7950	2000	1
▲	B-488	F A	48.26	6.35	–	M71-81-488	BMP71	M71-R4300	750	1
▲	B-499	F NA	48.26	6.35	–	M71-81-499	BMP71	M71-R4300	750	1
▲	B-499	F NA	48.26	25.40	–	M71-78-499	BMP71	M71-R4300	250	1
▲	B-499	F NA	50.80	6.35	–	B33-151-499	BBP33	B30-R6000HF	1500	1
▲	B-499	F NA	50.80	6.35	–	TH1-151-499-3	BBP12, BP-PR+, IP	R4900	3000	1
▲	B-499	F NA	50.80	6.35	–	TH1-151-499-1.5-SC	BBP12, BP-PR+	R7950	1500	1
▲	B-423	F AH	50.80	6.35	–	TH1-15-423-2.5	BBP12, BP-PR+, IP	R6000HF	2500	1
▲	B-423	F AH	63.50	5.08	–	TH1-142-423-2.5	BBP12, BP-PR+, IP	R6000HF	2500	1
▲	B-430	F AH	76.20	25.40	–	TH1-18-430-3	BBP12, BP-PR+, IP	R6000HF	3000	1
▲	B-430	F AH	76.20	50.80	–	TH1-19-430-1	BBP12, BP-PR+, IP	R6000HF	1000	1

**AW = All White / no transparent area.

BOTTLES / FLASKS & DISHES

Brady's labels for bottles, flasks and dishes are easy to handle and flexible. This enables the labels to be placed on curved containers and remain attached and legible, even after being subjected to freezing, liquid nitrogen and heat.

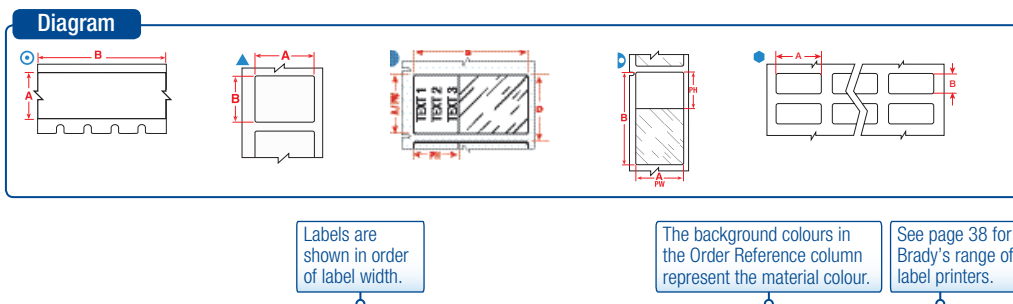
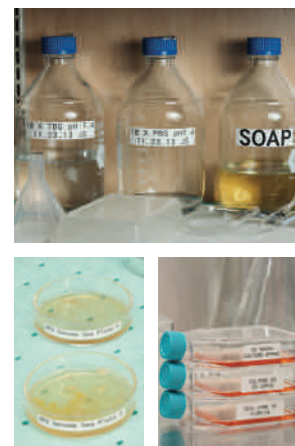

Diagram	Material	Special Properties	Label Width A (mm)	Label Height B (mm)	Label Length B (m)	Printable Area Width PW (mm)	Printable Area Height PH (mm)	Order Reference	Printer Compatibility	Printer Ribbon Series	Labels/Package	Labels per Row
⊙	B-423	F AH	6.35	—	6.40	—	—	M21-250-423	BMP21-LAB	—	1	1
⊙	B-430	F AH	6.35	—	6.40	—	—	M21-250-430	BMP21-LAB	—	1	1
⊙	B-430	F AH	6.35	—	6.40	—	—	M21-250-430-WT-CL	BMP21-LAB	—	1	1
⊙	B-499	F NA	9.53	—	4.88	—	—	M21-375-499	BMP21-LAB	—	1	1
⊙	B-499	F NA	9.53	—	4.88	—	—	MC-375-499	BMP51, BMP53	—	1	1
⊙	B-430	F AH	9.53	—	6.40	—	—	M21-375-430	BMP21-LAB	—	1	1
⊙	B-430	F AH	9.53	—	6.40	—	—	M21-375-430-WT-CL	BMP21-LAB	—	1	1
⊙	B-430	F AH	9.53	—	15.24	—	—	M71C-375-430	BMP71	M71-R6000HF	1	1
▲	B-499	F NA	9.53	20.96	—	—	—	M-130-499	BMP51, BMP53	—	220	1
⊙	B-499	F NA	12.70	—	4.88	—	—	M21-500-499	BMP21-LAB	—	1	1
⊙	B-499	F NA	12.70	—	4.88	—	—	MC-500-499	BMP51, BMP53	—	1	1
⊙	B-430	F AH	12.70	—	6.40	—	—	M21-500-430	BMP21-LAB	—	1	1
⊙	B-430	F AH	12.70	—	6.40	—	—	M21-500-430-WT-CL	BMP21-LAB	—	1	1
⊙	B-499	F NA	12.70	—	9.10	—	—	M71C-500-499	BMP71	M71-R4300	1	1
⊙	B-430	F AH	12.70	—	15.24	—	—	M71C-500-430	BMP71	M71-R6000HF	1	1
▲	B-423	F AH	12.70	12.70	—	—	—	BM71-7-423	BMP71	M71-R6000HF	5000	1
▲	B-423	F AH	12.70	12.70	—	—	—	M71-7-423	BMP71	M71-R6000HF	500	1
●	B-499	F NA	12.70	19.05	—	—	—	B33-68-499	BBP33	B30-R6000HF	1500	4
●	B-499	F NA	12.70	19.05	—	—	—	THT-68-499-10	BBP12, BP-PR+, IP	R4900	10000	4
▲	B-498	F R	12.70	25.40	—	—	—	M-131-498	BMP51, BMP53	—	180	1
▲	B-499	F NA	12.70	25.40	—	—	—	M-131-499	BMP51, BMP53	—	180	1
⊙	B-499	F NA	19.05	—	4.88	—	—	M21-750-499	BMP21-LAB	—	1	1
⊙	B-499	F NA	19.05	—	4.88	—	—	MC-750-499	BMP51, BMP53	—	1	1
⊙	B-430	F AH	19.05	—	6.40	—	—	M21-750-430	BMP21-LAB	—	1	1
⊙	B-430	F AH	19.05	—	6.40	—	—	M21-750-430-WT-CL	BMP21-LAB	—	1	1
▷	B-427	F N S	19.05	38.10	—	19.05	12.70	BM71-30-427	BMP71	M71-R4300	2500	1
▷	B-427	F N S	19.05	38.10	—	19.05	12.70	M-90-427	BMP51, BMP53	—	180	1
▷	B-427	F N S	19.05	38.10	—	19.05	12.70	M71-30-427	BMP71	M71-R4300	250	1
▲	B-427	F N S	20.00	20.00	—	20.00	20.00	BPTLAB-35-427-YL	BBP12, BP-PR+, IP	R7950	1000	1
▲	B-499	F NA	22.86	12.70	—	—	—	B33-125-499	BBP33	B30-R6000HF	1500	1
▲	B-499	F NA	22.86	12.70	—	—	—	THT-125-499-3	BBP12, BP-PR+, IP	R4900	3000	1
▲	B-499	F NA	22.86	12.70	—	—	—	THT-125-499-1.5-SC	BBP12, BP-PR+, IP	R7950	1500	1
●	B-488	F A	22.86	19.05	—	—	—	B33-616-488	BBP33	B30-R4300	3000	3
●	B-488	F A	22.86	19.05	—	—	—	THT-140-488-3	BBP12, BP-PR+, IP	R4300, R7950	3000	2
●	B-488	F A	22.86	19.05	—	—	—	THT-140-488-1.5-SC	BBP12, BP-PR+, IP	R7950	1500	2
●	B-488	F A	22.86	22.86	—	—	—	B33-617-488	BBP33	B30-R4300	3000	3
▲	B-488	F A	22.86	22.86	—	—	—	THT-164-488-1-SC	BBP12, BP-PR+, IP	R7950	1000	1
●	B-488	F A	22.86	22.86	—	—	—	THT-141-488-3	BBP12, BP-PR+, IP	R4300, R7950	3000	2
⊙	B-499	F NA	25.40	—	4.88	—	—	MC-1000-499	BMP51, BMP53	—	1	1
⊙	B-499	F NA	25.40	—	9.10	—	—	M71C-1000-499	BMP71	M71-R4300	1	1
⊙	B-430	F AH	25.40	—	15.24	—	—	M71C-1000-430	BMP71	M71-R6000HF	1	1
▲	B-423	F AH	25.40	4.75	—	—	—	M71-14-423	BMP71	M71-R6000HF	750	1
●	B-423	F AH	25.40	4.75	—	—	—	THT-41-423-10	BBP12, BP-PR+, IP	R6000	10000	3
●	B-423	F AH	25.40	6.35	—	—	—	THT-51-423-10	BBP12, BP-PR+, IP	R6000	10000	3
▲	B-423	F AH	25.40	6.99	—	—	—	M71-15-423	BMP71	M71-R6000HF	750	1
●	B-499	F NA	25.40	9.53	—	—	—	B33-152-499	BBP33	B30-R6000HF	1500	2
●	B-499	F NA	25.40	9.53	—	—	—	THT-152-499-3	BBP12, BP-PR+, IP	R4900	3000	2
●	B-499	F NA	25.40	9.53	—	—	—	THT-152-499-1.5-SC	BBP12, BP-PR+, IP	R7950	1500	2
●	B-425	F	25.40	9.98	—	—	—	THT-30-425-10	BBP12, BP-PR+, IP	R6400	10000	3
●	B-423	F AH	25.40	12.70	—	—	—	B33-5-423	BBP33	B30-R6000HF	5000	3
▲	B-423	F AH	25.40	12.70	—	—	—	M71-17-423	BMP71	M71-R6000HF	500	1
▲	B-498	F R	25.40	12.70	—	—	—	M71-17-498	BMP71	M71-R6200	500	1

>>>

Bottles / Flasks & Dishes

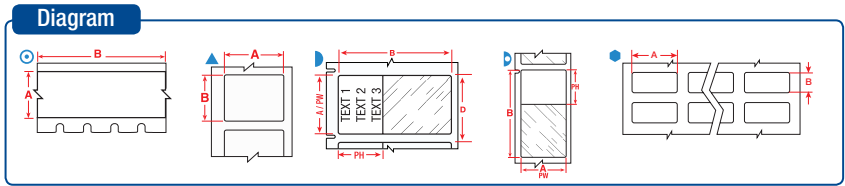

Diagram	Material	Special Properties	Label Width A (mm)	Label Height B (mm)	Label Length B (m)	Printable Area Width PW (mm)	Printable Area Height PH (mm)	Order Reference	Printer Compatibility	Printer Ribbon Series	Labels/Package	Labels per Row
▲	B-498	F R	25.40	12.70	-	-	-	THT-59-498-10	BBP12, BP-PR+, IP	R4300, R7950	10000	1
▲	B-533	F A R	25.40	12.70	-	-	-	THT-59-533-10	BBP12, BP-PR+, IP	R6000HF	10000	1
▲	B-498	F R	25.40	12.70	-	-	-	THT-59-498-2.5-SC	BBP12, BP-PR+, IP	R7950	2500	1
●	B-430	F AH	25.40	12.70	-	-	-	THT-39-430-10	BBP12, BP-PR+, IP	R6000HF	10000	3
●	B-488	F A	25.40	12.70	-	-	-	THT-5-488-10	BBP12, BP-PR+, IP	R4300, R7950	10000	3
●	B-492	F N H L	25.40	19.05	-	-	-	THT-88-492-5	BBP12, BP-PR+, IP	R6400	5000	2
▲	B-492	F N H L	25.40	25.40	-	-	-	M71-19-492	BMP71	M71-R6400	250	1
▲	B-499	F N A	25.40	25.40	-	-	-	M71-19-499	BMP71	M71-R4300	250	1
▲	B-498	F R	25.40	31.75	-	-	-	M-103-498	BMP51, BMP53	-	160	1
▷	B-427	F N S	25.40	38.10	-	25.40	12.70	BM71-31-427	BMP71	M71-R4300	2500	1
▷	B-427	F N S	25.40	38.10	-	25.40	12.70	M-91-427	BMP51, BMP53	-	180	1
▷	B-427	F N S	25.40	38.10	-	25.40	12.70	M71-31-427	BMP71	M71-R4300	250	1
▲	B-498	F R	25.40	48.26	-	-	-	M-128-498	BMP51, BMP53	-	100	1
▲	B-499	F N A	25.40	50.80	-	-	-	B33-137-499	BBP33	B30-R6000HF	1100	1
▲	B-423	F AH	25.40	50.80	-	-	-	BM71-20-423	BMP71	M71-R6000HF	1000	1
▲	B-423	F AH	25.40	50.80	-	-	-	M71-20-423	BMP71	M71-R6000HF	100	1
▲	B-423	F AH	25.40	76.20	-	-	-	M71-22-423	BMP71	M71-R6000HF	100	1
▲	B-498	F R	26.67	6.35	-	-	-	THT-199-498-3	BBP12, BP-PR+, IP	R4300, R7950	3000	1
▲	B-498	F R	26.67	6.35	-	-	-	THT-199-498-3-SC	BBP12, BP-PR+, IP	R7950	3000	1
▲	B-423	F AH	31.75	69.85	-	-	-	M71-26-423	BMP71	M71-R6000HF	100	1
▲	B-499	F N A	38.10	12.70	-	-	-	M71-29-499	BMP71	M71-R4300	500	1
▲	B-499	F N A	38.10	19.05	-	-	-	B33-136-499	BBP33	B30-R6000HF	1500	1
●	B-8423	F A	38.10	19.05	-	-	-	B33-6-8423	BBP33	B30-R6000HF	2500	2
▲	B-499	F N A	38.10	19.05	-	-	-	M71-30-499	BMP71	M71-R4300	250	1
▲	B-499	F N A	38.10	19.05	-	-	-	THT-136-499-3	BBP12, BP-PR+, IP	R4900	3000	1
▲	B-499	F N A	38.10	19.05	-	-	-	THT-136-499-1.5-SC	BBP12, BP-PR+, IP	R7950	1500	1
▲	B-427	F N S	38.10	19.05	-	38.10	19.05	M71-30-427-AW**	BMP71	M71-R4300	250	1
▲	B-423	F AH	38.10	25.40	-	-	-	M71-31-423	BMP71	M71-R6000HF	250	1
▲	B-499	F N A	38.10	25.40	-	-	-	M71-31-499	BMP71	M71-R4300	250	1
▲	B-499	F N A	38.10	31.75	-	-	-	M-132-499	BMP51, BMP53	-	160	1
◎	B-499	F N A	48.26	-	9.10	-	-	M71C-1900-499	BMP71	M71-R4300	1	1
◎	B-430	F AH	48.26	-	15.24	-	-	M71C-1900-430	BMP71	M71-R6000HF	1	1
▲	B-488	F A	48.26	6.35	-	-	-	B33-635-488	BBP33	B30-R4300	2000	1
▲	B-499	F N A	48.26	25.40	-	-	-	M71-78-499	BMP71	M71-R4300	250	1
▲	B-499	F N A	50.80	6.35	-	-	-	B33-151-499	BBP33	B30-R6000HF	1500	1
▲	B-499	F N A	50.80	6.35	-	-	-	THT-151-499-3	BBP12, BP-PR+, IP	R4900	3000	1
▲	B-499	F N A	50.80	6.35	-	-	-	THT-151-499-1.5-SC	BBP12, BP-PR+, IP	R7950	1500	1
▲	B-488	F A	50.80	6.35	-	-	-	THT-15-488-2.5	BBP12, BP-PR+, IP	R7950	2500	1
▲	B-423	F AH	50.80	25.40	-	-	-	B33-17-423	BBP33	B30-R6000HF	1500	1
▲	B-425	F	50.80	25.40	-	-	-	B33-17-425	BBP33	B30-R4300	1500	1
▲	B-430	F AH	50.80	25.40	-	-	-	B33-17-430	BBP33	B30-R6000HF	1500	1
▲	B-432	F A	50.80	25.40	-	-	-	B33-17-432	BBP33	B30-R6000HF	5000	1
▲	B-8423	F A	50.80	25.40	-	-	-	BPT-17-8423-1	BBP12, BP-PR+, IP	R6000HF	1000	1
▲	B-423	F AH	50.80	25.40	-	-	-	THT-17-423-3	BBP12, BP-PR+, IP	R6000HF	3000	1
▲	B-425	F	50.80	25.40	-	-	-	THT-17-425-3	BBP12, BP-PR+, IP	R6400	3000	1
▲	B-430	F AH	50.80	25.40	-	-	-	THT-17-430-3	BBP12, BP-PR+, IP	R6000HF	3000	1
▲	B-498	F R	50.80	25.40	-	-	-	THT-17-498-3	BBP12, BP-PR+, IP	R4300, R7950	3000	1
▲	B-533	F A R	50.80	25.40	-	-	-	THT-17-533-3	BBP12, BP-PR+, IP	R6000HF	3000	1
▲	B-498	F R	50.80	25.40	-	-	-	THT-17-498-1.5-SC	BBP12, BP-PR+, IP	R7950	1500	1
▲	B-8423	F A	69.85	31.75	-	-	-	BPT-7-8423-1	BBP12, BP-PR+, IP	R6000HF	1000	1
▲	B-423	F AH	76.20	25.40	-	-	-	B33-18-423	BBP33	B30-R6000HF	1500	1
▲	B-430	F AH	76.20	25.40	-	-	-	B33-18-430	BBP33	B30-R6000HF	1500	1
▲	B-432	F A	76.20	25.40	-	-	-	B33-18-432	BBP33	B30-R6000HF	1500	1
▲	B-423	F AH	76.20	25.40	-	-	-	THT-18-423-3	BBP12, BP-PR+, IP	R6000HF	3000	1
▲	B-432	F A	76.20	50.80	-	-	-	B33-19-432	BBP33	B30-R6000HF	500	1
▲	B-432	F A	76.20	50.80	-	-	-	THT-19-432-1	BBP12, BP-PR+, IP	R6000HF	1000	1
▲	B-490	F N H L	95.25	38.10	-	-	-	THT-158-490-3	BBP12, BP-PR+, IP	R4300, R7950	3000	1
▲	B-490	F N H L	95.25	38.10	-	-	-	THT-158-490-1.5-SC	BBP12, BP-PR+, IP	R7950	1500	1

**AW = All White / no transparent area.

F Freezer environment N Liquid nitrogen environment A Autoclave environment H Hot water bath (100°C) S Self-laminating label L Low-profile (extremely thin) label R Removable

- F** Freezer environment
- N** Liquid nitrogen environment
- A** Autoclave environment
- H** Hot water bath (100°C)
- S** Self-laminating label
- L** Low-profile (extremely thin) label
- R** Removable

BOTTLE TAMPER SEAL LABELS

Brady's bottle seal identification provides tracking information with the added feature of security. These labelling materials are designed to fracture easily in order to show signs of sample tampering and to prevent one-piece label removal.

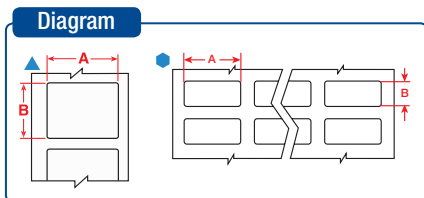

Labels are shown in order of label width.

The background colours in the Order Reference column represent the material colour.

See page 38 for Brady's range of label printers.

Diagram	Material	Special Properties	Label Width A (mm)	Label Height B (mm)	Order Reference	Printer Compatibility	Printer Ribbon Series	Labels/Package	Labels per Row
▲	B-351	F	25.40	12.70	M-17-351	BMP51, BMP53	—	360	1
▲	B-351	F	25.40	12.70	M71-17-351	BMP71	M71-R6000HF	500	1
●	B-7351	F	25.40	12.70	THT-5-7351-10	BBP12, BP-PR+, IP	R6000	10000	3
▲	B-351	F	25.40	50.80	M-20-351	BMP51, BMP53	—	160	1
▲	B-351	F	25.40	50.80	M71-20-351	BMP71	M71-R6000HF	100	1
▲	B-351	F	38.10	25.40	M71-31-351	BMP71	M71-R6000HF	250	1
▲	B-7351	F	50.80	25.40	THT-17-7351-3	BBP12, BP-PR+, IP	R6000	3000	1
▲	B-351	F	76.20	48.26	M71-37-351	BMP71	M71-R6000HF	100	1



To find out how Brady helps some of the world's leading research laboratories develop more efficient labelling protocols visit www.bradyeurope.com/lab



Part number explanation

Most Brady references for printable labels follow the same three-part format: The first code indicates the technology, the second part is a number indicating the label size (where applicable) and the third part indicates the Brady material (where applicable).

M71-73-461

BMP71
Technology

Label size
code

Material
(B-number)



GENERAL LAB ID

Just like a durable sample label lets you know which sample you are holding, a cabinet or drawer label can inform you of the cabinet's content. With proper identification, time spent looking for the right sample or tool can be invested in what really matters. Brady offers a range of materials suitable for identifying drawers, cabinets, shelves, storage units and laboratory equipment.

- F** Freezer environment
- N** Liquid nitrogen environment
- A** Autoclave environment
- H** Hot water bath (100°C)
- S** Self-laminating label
- L** Low-profile (extremely thin) label
- R** Removable

Diagram

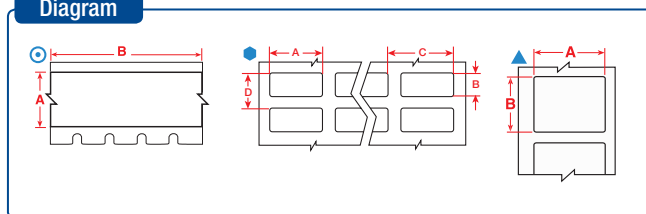

Labels are shown in order of label width.

The background colours in the Order Reference column represent the material colour

See page 38 for Brady's range of label printers.

Diagram	Material	Special Properties	Label Width A (mm)	Label Height B (mm)	Label Length B (m)	Order Reference	Printer Compatibility	Printer Ribbon Series	Labels/Package	Labels per Row
⊙	B-423	F A H	6.35	—	6.40	M21-250-423	BMP21-LAB	—	1	1
⊙	B-430	F A H	6.35	—	6.40	M21-250-430	BMP21-LAB	—	1	1
⊙	B-595	F	6.35	—	6.40	M21-250-595-WT	BMP21-LAB	—	1	1
⊙	B-430	F A H	6.35	—	6.40	M21-250-430-WT-CL	BMP21-LAB	—	1	1
⊙	B-595	F	6.35	—	6.40	M21-250-595-YL	BMP21-LAB	—	1	1
⊙	B-499	F N A	9.53	—	4.88	M21-375-499	BMP21-LAB	—	1	1
⊙	B-499	F N A	9.53	—	4.88	MC-375-499	BMP51, BMP53	—	1	1
⊙	B-423	F A H	9.53	—	6.40	M21-375-423	BMP21-LAB	—	1	1
⊙	B-430	F A H	9.53	—	6.40	M21-375-430	BMP21-LAB	—	1	1
⊙	B-488	F A	9.53	—	6.40	M21-375-488	BMP21-LAB	—	1	1
⊙	B-595	F	9.53	—	6.40	M21-375-595-BK	BMP21-LAB	—	1	1
⊙	B-595	F	9.53	—	6.40	M21-375-595-BL	BMP21-LAB	—	1	1
⊙	B-595	F	9.53	—	6.40	M21-375-595-GN	BMP21-LAB	—	1	1
⊙	B-595	F	9.53	—	6.40	M21-375-595-OR	BMP21-LAB	—	1	1
⊙	B-595	F	9.53	—	6.40	M21-375-595-RD	BMP21-LAB	—	1	1
⊙	B-595	F	9.53	—	6.40	M21-375-595-WT	BMP21-LAB	—	1	1
⊙	B-430	F A H	9.53	—	6.40	M21-375-430-WT-CL	BMP21-LAB	—	1	1
⊙	B-595	F	9.53	—	6.40	M21-375-595-YL	BMP21-LAB	—	1	1
⊙	B-595	F	9.53	—	7.62	MC-375-595-WT-BK	BMP51, BMP53	—	1	1
⊙	B-595	F	9.53	—	7.62	MC-375-595-YL-BK	BMP51, BMP53	—	1	1
⊙	B-430	F A H	9.53	—	15.24	M71C-375-430	BMP71	M71-R6000HF	1	1
▲	B-499	F N A	9.53	20.96	—	M-130-499	BMP51, BMP53	—	220	1
⊙	B-499	F N A	12.70	—	4.88	M21-500-499	BMP21-LAB	—	1	1
⊙	B-499	F N A	12.70	—	4.88	MC-500-499	BMP51, BMP53	—	1	1
⊙	B-595	F	12.70	—	6.10	MC-500-595-CL-BK	BMP51, BMP53	—	1	1
⊙	B-595	F	12.70	—	6.10	MC-500-595-CL-WT	BMP51, BMP53	—	1	1
⊙	B-423	F A H	12.70	—	6.40	M21-500-423	BMP21-LAB	—	1	1
⊙	B-430	F A H	12.70	—	6.40	M21-500-430	BMP21-LAB	—	1	1
⊙	B-488	F A	12.70	—	6.40	M21-500-488	BMP21-LAB	—	1	1
⊙	B-595	F	12.70	—	6.40	M21-500-595-BK	BMP21-LAB	—	1	1
⊙	B-595	F	12.70	—	6.40	M21-500-595-BL	BMP21-LAB	—	1	1
⊙	B-595	F	12.70	—	6.40	M21-500-595-GN	BMP21-LAB	—	1	1
⊙	B-595	F	12.70	—	6.40	M21-500-595-OR	BMP21-LAB	—	1	1
⊙	B-595	F	12.70	—	6.40	M21-500-595-RD	BMP21-LAB	—	1	1
⊙	B-595	F	12.70	—	6.40	M21-500-595-WT	BMP21-LAB	—	1	1
⊙	B-430	F A H	12.70	—	6.40	M21-500-430-WT-CL	BMP21-LAB	—	1	1
⊙	B-595	F	12.70	—	6.40	M21-500-595-YL	BMP21-LAB	—	1	1
⊙	B-595	F	12.70	—	7.62	MC-500-595-BK-WT	BMP51, BMP53	—	1	1
⊙	B-595	F	12.70	—	7.62	MC-500-595-BL-WT	BMP51, BMP53	—	1	1
⊙	B-595	F	12.70	—	7.62	MC-500-595-GN-WT	BMP51, BMP53	—	1	1
⊙	B-595	F	12.70	—	7.62	MC-500-595-OR-BK	BMP51, BMP53	—	1	1
⊙	B-595	F	12.70	—	7.62	MC-500-595-RD-WT	BMP51, BMP53	—	1	1

>>

Diagram

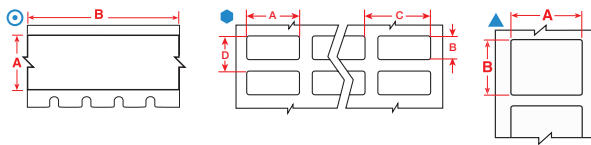
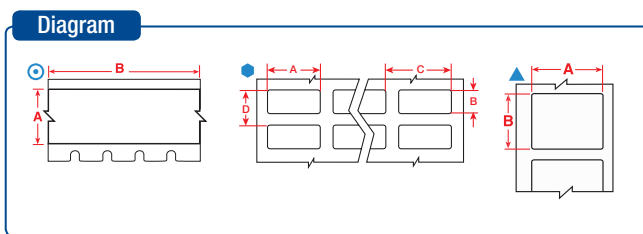

Diagram	Material	Special Properties	Label Width A (mm)	Label Height B (mm)	Label Length B (m)	Order Reference	Printer Compatibility	Printer Ribbon Series	Labels/Package	Labels per Row
⊙	B-595	F	12.70	–	7.62	MC-500-595-WT-BK	BMP51, BMP53	–	1	1
⊙	B-595	F	12.70	–	7.62	MC-500-595-WT-RD	BMP51, BMP53	–	1	1
⊙	B-595	F	12.70	–	7.62	MC-500-595-YL-BK	BMP51, BMP53	–	1	1
⊙	B-499	F N A	12.70	–	9.10	M71C-500-499	BMP71	M71-R4300	1	1
⊙	B-430	F A H	12.70	–	15.24	M71C-500-430	BMP71	M71-R6000HF	1	1
⊙	B-595	F	12.70	–	15.24	M71C-500-595-BK	BMP71	M71-R6000HF	1	1
⊙	B-595	F	12.70	–	15.24	M71C-500-595-BL	BMP71	M71-R6000HF	1	1
⊙	B-595	F	12.70	–	15.24	M71C-500-595-CL	BMP71	M71-R6000HF	1	1
⊙	B-595	F	12.70	–	15.24	M71C-500-595-GN	BMP71	M71-R6000HF	1	1
⊙	B-595	F	12.70	–	15.24	M71C-500-595-OR	BMP71	M71-R6000HF	1	1
⊙	B-595	F	12.70	–	15.24	M71C-500-595-RD	BMP71	M71-R6000HF	1	1
⊙	B-595	F	12.70	–	15.24	M71C-500-595-WT	BMP71	M71-R6000HF	1	1
⊙	B-595	F	12.70	–	30.40	M71C-500-595-YL	BMP71	M71-R6000HF	1	1
⊙	B-595	F	12.70	–	30.40	B30C-500-595-BK	BBP33	B30-R10000-WT	1	1
⊙	B-595	F	12.70	–	30.40	B30C-500-595-BL	BBP33	B30-R10000-WT	1	1
⊙	B-595	F	12.70	–	30.40	B30C-500-595-CL	BBP33	B30-R10000	1	1
⊙	B-595	F	12.70	–	30.40	B30C-500-595-GN	BBP33	B30-R10000-WT	1	1
⊙	B-595	F	12.70	–	30.40	B30C-500-595-OR	BBP33	B30-R10000	1	1
⊙	B-595	F	12.70	–	30.40	B30C-500-595-RD	BBP33	B30-R10000-WT	1	1
⊙	B-595	F	12.70	–	30.40	B30C-500-595-WT	BBP33	B30-R10000	1	1
⊙	B-595	F	12.70	–	30.40	B30C-500-595-YL	BBP33	B30-R10000	1	1
▲	B-498	F R	12.70	25.40	–	M-131-498	BMP51, BMP53	–	180	1
▲	B-499	F N A	12.70	25.40	–	M-131-499	BMP51, BMP53	–	180	1
▲	B-424	F	12.70	50.80	–	B33-53-424	BBP33	B30-R4300	2500	1
⊙	B-499	F N A	19.05	–	4.88	M21-750-499	BMP21-LAB	–	1	1
⊙	B-499	F N A	19.05	–	4.88	MC-750-499	BMP51, BMP53	–	1	1
⊙	B-595	F	19.05	–	6.10	MC-750-595-CL-BK	BMP51, BMP53	–	1	1
⊙	B-595	F	19.05	–	6.10	MC-750-595-CL-WT	BMP51, BMP53	–	1	1
⊙	B-423	F A H	19.05	–	6.40	M21-750-423	BMP21-LAB	–	1	1
⊙	B-430	F A H	19.05	–	6.40	M21-750-430	BMP21-LAB	–	1	1
⊙	B-488	F A	19.05	–	6.40	M21-750-488	BMP21-LAB	–	1	1
⊙	B-595	F	19.05	–	6.40	M21-750-595-BK	BMP21-LAB	–	1	1
⊙	B-595	F	19.05	–	6.40	M21-750-595-BL	BMP21-LAB	–	1	1
⊙	B-595	F	19.05	–	6.40	M21-750-595-GN	BMP21-LAB	–	1	1
⊙	B-595	F	19.05	–	6.40	M21-750-595-OR	BMP21-LAB	–	1	1
⊙	B-595	F	19.05	–	6.40	M21-750-595-RD	BMP21-LAB	–	1	1
⊙	B-595	F	19.05	–	6.40	M21-750-595-WT	BMP21-LAB	–	1	1
⊙	B-430	F A H	19.05	–	6.40	M21-750-430-WT-CL	BMP21-LAB	–	1	1
⊙	B-595	F	19.05	–	6.40	M21-750-595-YL	BMP21-LAB	–	1	1
⊙	B-595	F	19.05	–	7.62	MC-750-595-BK-WT	BMP51, BMP53	–	1	1
⊙	B-595	F	19.05	–	7.62	MC-750-595-BL-WT	BMP51, BMP53	–	1	1
⊙	B-595	F	19.05	–	7.62	MC-750-595-GN-WT	BMP51, BMP53	–	1	1
⊙	B-595	F	19.05	–	7.62	MC-750-595-OR-BK	BMP51, BMP53	–	1	1
⊙	B-595	F	19.05	–	7.62	MC-750-595-RD-WT	BMP51, BMP53	–	1	1
⊙	B-595	F	19.05	–	7.62	MC-750-595-WT-BK	BMP51, BMP53	–	1	1
⊙	B-595	F	19.05	–	7.62	MC-750-595-WT-RD	BMP51, BMP53	–	1	1
⊙	B-595	F	19.05	–	7.62	MC-750-595-YL-BK	BMP51, BMP53	–	1	1
⊙	B-499	F N A	25.40	–	4.88	MC-1000-499	BMP51, BMP53	–	1	1
⊙	B-595	F	25.40	–	6.10	MC1-1000-595-CL-BK	BMP51, BMP53	–	1	1
⊙	B-595	F	25.40	–	6.10	MC1-1000-595-CL-WT	BMP51, BMP53	–	1	1
⊙	B-595	F	25.40	–	7.62	MC1-1000-595-BK-WT	BMP51, BMP53	–	1	1
⊙	B-595	F	25.40	–	7.62	MC1-1000-595-BL-WT	BMP51, BMP53	–	1	1
⊙	B-595	F	25.40	–	7.62	MC1-1000-595-GN-WT	BMP51, BMP53	–	1	1
⊙	B-595	F	25.40	–	7.62	MC1-1000-595-OR-BK	BMP51, BMP53	–	1	1
⊙	B-595	F	25.40	–	7.62	MC1-1000-595-RD-WT	BMP51, BMP53	–	1	1
⊙	B-595	F	25.40	–	7.62	MC1-1000-595-WT-BK	BMP51, BMP53	–	1	1
⊙	B-595	F	25.40	–	7.62	MC1-1000-595-WT-RD	BMP51, BMP53	–	1	1
⊙	B-595	F	25.40	–	7.62	MC1-1000-595-YL-BK	BMP51, BMP53	–	1	1
⊙	B-499	F N A	25.40	–	9.10	M71C-1000-499	BMP71	M71-R4300	1	1
⊙	B-430	F A H	25.40	–	15.24	M71C-1000-430	BMP71	M71-R6000HF	1	1

>>

General Lab ID



Labels are shown in order of label width.

The background colours in the Order Reference column represent the material colour.

See page 38 for Brady's range of label printers.

Diagram	Material	Special Properties	Label Width A (mm)	Label Height B (mm)	Label Length B (m)	Order Reference	Printer Compatibility	Printer Ribbon Series	Labels/Package	Labels per Row
⊙	B-595	F	25.40	–	15.24	M71C-1000-595-BK	BMP71	M71-R4400-WT	1	1
⊙	B-595	F	25.40	–	15.24	M71C-1000-595-BL	BMP71	M71-R4400-WT	1	1
⊙	B-595	F	25.40	–	15.24	M71C-1000-595-CL	BMP71	M71-R6000HF	1	1
⊙	B-595	F	25.40	–	15.24	M71C-1000-595-GN	BMP71	M71-R4400-WT	1	1
⊙	B-595	F	25.40	–	15.24	M71C-1000-595-OR	BMP71	M71-R6000HF	1	1
⊙	B-595	F	25.40	–	15.24	M71C-1000-595-RD	BMP71	M71-R4400-WT	1	1
⊙	B-595	F	25.40	–	15.24	M71C-1000-595-WT	BMP71	M71-R6000HF	1	1
⊙	B-595	F	25.40	–	15.24	M71C-1000-595-YL	BMP71	M71-R6000HF	1	1
⬢	B-423	F A H	25.40	12.70	–	B33-5-423	BBP33	B30-R6000HF	5000	3
▲	B-432	F A	25.40	12.70	–	M-17-432-CL-BK	BMP51, BMP53	–	280	1
▲	B-430	F A H	25.40	12.70	–	M71-17-430	BMP71	M71-R6000HF	500	1
▲	B-498	F R	25.40	12.70	–	M71-17-498	BMP71	M71-R6200	500	1
▲	B-498	F R	25.40	12.70	–	THT-59-498-2.5-SC	BBP12, BP-PR+	R7950	2500	1
⬢	B-488	F A	25.40	12.70	–	THT-5-488-10	BBP12, BP-PR+	R4300, R7950	10000	3
▲	B-492	F N H L	25.40	25.40	–	M71-19-492	BMP71	M71-R6400	250	1
▲	B-499	F N A	25.40	25.40	–	M71-19-499	BMP71	M71-R4300	250	1
▲	B-498	F R	25.40	31.75	–	M-103-498	BMP51, BMP53	–	160	1
▲	B-498	F R	25.40	48.26	–	M-128-498	BMP51, BMP53	–	100	1
▲	B-432	F A	25.40	48.26	–	M-78-432-CL-BK	BMP51, BMP53	–	100	1
▲	B-424	F	25.40	50.80	–	BM71-20-424	BMP71	M71-R4300	1000	1
▲	B-424	F	25.40	50.80	–	M71-20-424	BMP71	M71-R4300	100	1
▲	B-498	F R	26.67	6.35	–	THT-199-498-3	BBP12, BP-PR+	R4300, R7950	3000	1
▲	B-498	F R	26.67	6.35	–	THT-199-498-3-SC	BBP12, BP-PR+	R7950	3000	1
▲	B-423	F A H	31.75	69.85	–	M71-26-423	BMP71	M71-R6000HF	100	1
⬢	B-423	F A H	38.10	19.05	–	THT-6-423-10	BBP12, BP-PR+	R6000HF	10000	2
⬢	B-449	F A R	38.10	19.05	–	THT-6-449-3	BBP12, BP-PR+	R4300, R7950	3000	2
⬢	B-449	F A R	38.10	19.05	–	THT-6-449-1.5-SC	BBP12, BP-PR+	R7950	1500	2
▲	B-499	F N A	38.10	31.75	–	M-132-499	BMP51, BMP53	–	160	1
⊙	B-499	F N A	48.26	–	9.10	M71C-1900-499	BMP71	M71-R4300	1	1
⊙	B-430	F A H	48.26	–	15.24	M71C-1900-430	BMP71	M71-R6000HF	1	1
▲	B-423	F A H	50.80	12.70	–	THT-53-423-3	BBP12, BP-PR+	R6000HF	3000	1
▲	B-424	F	50.80	12.70	–	THT-53-424-3	BBP12, BP-PR+	R4300, R7950	3000	1
▲	B-423	F A H	50.80	25.40	–	B33-17-423	BBP33	B30-R6000HF	1500	1
▲	B-424	F	50.80	25.40	–	B33-17-424	BBP33	B30-R4300	1500	1
▲	B-8423	F A	50.80	25.40	–	BPT-17-8423-1	BBP12, BP-PR+	R6000HF	1000	1
▲	B-423	F A H	50.80	25.40	–	THT-17-423-3	BBP12, BP-PR+	R6000HF	3000	1
▲	B-424	F	50.80	25.40	–	THT-17-424-3	BBP12, BP-PR+	R4300, R7950	3000	1
▲	B-449	F A R	50.80	25.40	–	THT-17-449-3	BBP12, BP-PR+	R4300, R7950	3000	1
▲	B-498	F R	50.80	25.40	–	THT-17-498-3	BBP12, BP-PR+	R4300, R7950	3000	1
▲	B-449	F A R	50.80	25.40	–	THT-17-449-1.5-SC	BBP12, BP-PR+	R7950	1500	1
▲	B-498	F R	50.80	25.40	–	THT-17-498-1.5-SC	BBP12, BP-PR+	R7950	1500	1
▲	B-8423	F A	69.85	31.75	–	BPT-7-8423-1	BBP12, BP-PR+	R6000HF	1000	1
▲	B-423	F A H	76.20	25.40	–	B33-18-423	BBP33	B30-R6000HF	1500	1
▲	B-423	F A H	76.20	25.40	–	THT-18-423-3	BBP12, BP-PR+	R6000HF	3000	1
▲	B-430	F A H	76.20	25.40	–	THT-18-430-3	BBP12, BP-PR+	R6000HF	3000	1
▲	B-430	F A H	76.20	25.40	–	THT-19-430-1	BBP12, BP-PR+	R6000HF	1000	1

Choose Your Printer



BMP™21-LAB Label Printer

BMP™51 Label Maker

BMP™71 Label Printer

The BMP™21-LAB Portable Label Printer is an all-in-one labeller for research, academic and clinical labs. The BMP21-LAB printer can quickly and easily create legible labels for flat, curved or highly textured surfaces that stay stuck for years even when exposed to extreme temperatures and chemicals.

A powerful portable printer for on the job labelling in laboratories. With its extensive connectivity and networking options this easy to use system prints a large variety of high quality continuous and die-cut materials up to 38 mm wide.

The most versatile portable printer for on the job labelling in laboratories. With its optimal efficiency it helps to reduce material waste and saves label making time. It prints on the largest variety of high quality continuous and die-cut materials up to 50 mm wide and offers an option to have custom materials created.

i BMP™21-LAB cartridges can be used in the first generation BMP™21 and LABPAL™ Label Printer.



Features

Recommended Usage per Day	100	500	1000 50.8x25.4mm labels per day
Resolution (dpi)	203 dpi	300 dpi	300 dpi
Print Technology	Thermal Transfer	Thermal Transfer	Thermal Transfer
Print Speed (mm/sec)	10.00	25.40	38.10
Max Label Width	19.00 mm	38.10 mm	50.80 mm
Text Sizes (pt)	6 - 40	4 - 102	4 - 174
Max Print Width	16.00 mm	36.00 mm	45.97 mm
Bar Code Capability	Code 39 and 128	Code 39 and 128, other via software	Code 39 and 128, other via software
Built-in Symbols	44 symbols included	450 symbols included	500+ symbols included
Flash Memory	Stores 12 labels	48 MB - up to 25,000 labels	200 MB - up to 100,000 labels
Materials Supported	60+ standard parts: continuous tapes	200+ standard parts : continuous tapes and die cut labels	400+ standard parts: continuous tapes, die cut and bulk label rolls, custom made labels and tapes
Stand-alone Printing (Detached from PC)	Stand-alone	Stand-alone & Peripheral	Stand-alone & Peripheral
Colour Capability	Monocolour	Monocolour	Monocolour
Connectivity	-	USB, Bluetooth. Optional: Ethernet, WiFi	USB
Keyboard	ABC	QWERTY	QWERTY, QWERTZ, AZERTY, CYRILLIC
Power Supply	6 AA's, AC Power, Li-ion rechargeable battery	8 AA's, Rechargeable Lithium Ion Battery, AC Power	Rechargeable NiMH Battery, AC Power
Weight (kg)	0.75 kg	1.40 kg	2.49 kg

Choose Your Printer



BBP™12 Label Printer

The BBP™12 Label Printer is an entry level benchtop label printer for cable, component, product and laboratory sample identification that offers great value for money. The compact BBP12 offers a high print speed of 100 mm/second and can handle a wide range of highly durable and specialised Brady identification labels.

BBP™33 Label Printer

Completely hassle free, easy to use PC-based printer. Smart chip supplies automatically set up the label in your Brady software. Drop-in ribbon and label cartridges ensure fast and effortless material changes.

Brady IP™ Printer

The revolutionary IP™ Printer System - gives you "Hassle Free" printing. The Brady IP Printer is a fully integrated, easy-to-use printer, material, and software system. Smart Cell technology allows the printer, materials, and ribbon to communicate!

BradyPrinter™ BP-PR Plus Series

A rugged industrial printer series, meets the demanding need for high volume usage of professional sample identification in laboratories.

Features

Recommended Usage per Day	500	1000	5000	7000
Resolution (dpi)	300 dpi	300	300 / 600	203 / 300 / 600
Print Technology	Thermal Transfer	Thermal Transfer	Thermal Transfer	Thermal Transfer
Print Speed (mm/sec)	100	101.60	200	254.00
Max Label Width	112 mm	106.00 mm	105.60 mm	116.00 mm
Text Sizes (pt)	–	–	–	–
Max Print Width	105.6 mm	101.60 mm	105.66 mm	105.60 mm
Bar Code Capability	2D and 1D (Linear)	Via software	Via software	Via software
Built-in Symbols	–	–	–	–
Flash Memory	64 MB	4 GB	8 MB	8 MB
Materials Supported	Nylon Cloth, Paper, Polyester, Polyethylene, Polyimide, Polyolefin (Sleeves), Polypropylene, Thermoplastic polyether-polyurethane, Vinyl, Vinyl Cloth, Outdoor Vinyl, Self-laminating Vinyl	Die Cut, Continuous & Custom	Die Cut, Continuous & Custom	Die Cut, Continuous & Custom
Stand-alone Printing (Detached from PC)	Stand-alone & Peripheral	Peripheral	Stand-alone & Peripheral	Stand-alone & Peripheral
Colour Capability	Monocolour	Monocolour	Monocolour	Monocolour
Connectivity	Serial, USB, Ethernet	USB, Ethernet. Optional: WiFi, Bluetooth	USB, Serial, Ethernet. Optional: WiFi	Serial, Parallel, USB, Ethernet
Keyboard	Optional	None	None	None
Hardware Options	Peel & Present, Universal Keyboard	Cutter	Cutter	Cutter, Peel Off
Weight (kg)	2.5 kg	5.30 kg	5.90 kg	8.50 kg

BBP™12 LABEL PRINTER

The BBP™12 Label Printer is an entry level benchtop label printer for cable, component, product and laboratory sample identification that offers great value for money. The compact BBP12 offers a high print speed of 100 mm/second and can handle a wide range of highly durable and specialised Brady identification labels.



SIMPLE, EFFICIENT DESIGN

- Compact in size, fits on every desk
- Default Ethernet Connectivity, allowing you to work in a network
- Connect any universal keyboard via USB 2.0 to work in stand-alone mode
- Full colour LCD Display and intuitive software interface are simple to use, so no extensive training is required
- Simple calibration menu with easy 1-2-3 step printing
- Best price/quality in the market for low volume printing
- Comes with a free unwinder accessory to print larger label rolls

PERFORMANCE

- Prints a wide range of identification labels from 6 mm up to 112 mm wide
- Standard 300 dpi print quality allowing accurate image & barcode positioning on small labels
- With its powerful 32 bit processor and its extended memory it can print up to 100 mm / sec
- The printer supports the industry-standard Zebra® and Eltron® programming languages
- Print time and date on to your labels via the “Real time clock feature”



While the BBP™12 label printer primarily uses 25.40 mm core materials for low to medium volume printing, an unwinder is available should high volume printing be needed.

BBP™12 LABEL PRINTER

Art. No.	Order Reference	Description
195566	BBP12-EU+Unwinder	BBP12 Label printer 300 dpi - EU with Unwinder
195567	BBP12-UK+Unwinder	BBP12 Label printer 300 dpi - UK with Unwinder
195568	BBP12-US+Unwinder	BBP12 Label printer 300 dpi - US with Unwinder
195569	BBP12-EU+U+LM PRO	BBP12 Label printer 300 dpi - EU with Unwinder and LabelMark Pro Software
195570	BBP12-UK+U+LM PRO	BBP12 Label printer 300 dpi - UK with Unwinder and LabelMark Pro Software
195571	BBP12-US+U+LM PRO	BBP12 Label printer 300 dpi - US with Unwinder and LabelMark Pro Software

ACCESSORY

Art. No.	Order Reference	Description
361064	BBP12/BBP11-VP	Peel and Present

BSP™31 LABEL ATTACHMENT SYSTEM

- Brady has developed a unique set of products for the histology and anatomic pathology market in order to guarantee pre-process identification for tissue samples allowing traceability throughout laboratory processes as well as long term storage (< 20 years).
- The BSP™31 Label Attachment System is designed to mechanically fasten an adhesive label to a tissue cassette before the tissue embedding process. This easy-to-use unit creates rivets on the label which prevent the label from detaching during the embedding process or during long-term storage
- When a cassette is inserted into the front of the unit, a clamp automatically grabs the cassette. In less than a minute, four small heat probes pierce through the label and front plastic of the cassette. Heat applied to the probes melts the cassette plastic and forms rivets on the label. When the unit retracts the probes from the cassette, the cassette is released and the user can remove it and place the biospecimen onto the cassette.
- The BSP™31 unit must be used exclusively with Brady B-482 label material and the R6400 thermal transfer printer ribbon.



Art. No.	Order Reference	Description
804850	BSP31 LABEL ATTACHMENT SYSTEM EUROPE	BSP31 Suitable for Europe and UK
804855	BSP31 -KIT LIGHT EUR	BSP31 Light Kit Europe version - 220V
804856	BSP31 -KIT LIGHT UK	BSP31 Light Kit UK version - 240V
804858	BSP31 -KIT FULL EUR	BSP31 Full Kit Europe version - 220V
804859	BSP31 -KIT FULL UK	BSP31 Full Kit UK version - 240V
114631	BRUSH KIT,BSP31	Cleaning Brushes for the BSP31
804866	ASSY FILTER BSP31 RC	Filter for the BSP31

Light Kit: BSP31 Label Attachment System, BBP12 300 dpi Printer, Codesoft Basic

Full Kit: BSP31 Label Attachment System, BBP12 300 dpi Printer, Codesoft Basic, CR1400 bar code reader with 1.83 m USB cable, Thermal Transfer Printable Labels BPT-164-481 & THT-199-482-3-SC, Black Thermal Transfer Printer Ribbon R6400 65mm x 70m /O



B-482 Tissue cassette labels

“We have received very positive feedback on the Brady cassette labels from researchers. They report that, as well as looking much more professional, the printed labels save time when they need to search through their archived blocks for a particular sample. Black text printed on a white label is very much quicker and easier to read than pencil on a green cassette. The clear labels therefore eliminate any confusion or mistakes which could occur with handwritten data.”

Cardiff University – School of Biosciences, UK



B-498 Re-Identify Tissue Cassettes Labels

Tissue cassettes are often re-identified when labs collect samples from various biorepositories. Typically, each laboratory has its own unique way of identifying samples, which creates a need to re-identify samples in a common way.

Brady B-498 post-process labels offer customers the optimal way to organise these specimens and conduct further studies. These labels can be applied directly onto the cassettes, on pure paraffin wax and on top of another label or identifier.

This is not the same as Brady's B-482 tissue cassette solution. B-498 Re-identify labels are applied after processing and are never used with the BSP31 label attachment system.





Wolf Laboratories Limited

www.wolflabs.co.uk

Wolflabs

Tel: 01759 301142

Fax: 01759 301143

sales@wolflabs.co.uk



Use the above details to contact us if this literature doesn't answer all your questions.

Pricing on any accessories shown can be found by keying the part number into the search box on our website.

The specifications listed in this brochure are subject to change by the manufacturer and therefore cannot be guaranteed to be correct. If there are aspects of the specification that must be guaranteed, please provide these to our sales team so that details can be confirmed.

