

# Model KBF-S 1020 | Constant climate chambers with large temperature / humidity range

The Solid.Line KBF-S climate chamber is a custom-made solution for long-term testing and accelerated stability testing of pharmaceutical products in accordance with the ICH Q1A guideline. The corrosion-free and condensation-free interior also ensures exceptionally stable temperature and moisture levels, even when fully loaded.

## BENEFITS

- Safe thanks to climatic homogeneity that far exceeds the accuracy required by ICH guidelines, even with a fully loaded unit.
- Reliable thanks to failsafe operation without compromise. The interior and Longlife evaporator plate are made entirely from stainless steel.
- Smart, as a wide range of accessories makes it highly compatible for adaptation to specific customer requirements.
- Economical thanks to maximum effective volume which allows for 30% larger load compared to the competition.

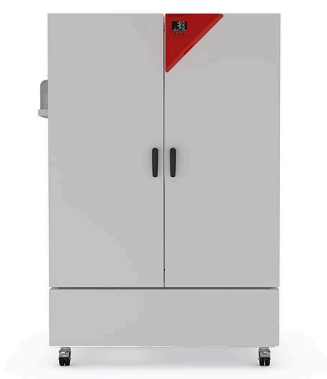

Model 1020



Model 1020

## MAIN FEATURES

- Temperature range: 0 °C to +70 °C
- Humidity range: 20% to 80% RH
- APT.line™ preheating chamber technology
- Humidity regulation with capacitive humidity sensor and steam humidification
- LCD to display temperature and humidity along with additional information and alarms
- Internal data logger, measured values can be read out in open format via USB
- Unit self-test for comprehensive status analysis
- Inner chamber made completely of stainless steel
- 2 stainless steel racks, incl. shelf supports
- Access port with silicone plug, 30 mm, left
- Robust twin casters with brakes, from 240 L
- Class 3.1 independent temperature safety device (DIN 12880) with visual and audible temperature alarm
- Computer interface: Ethernet
- Independent water supply via tank

## ORDERING INFORMATION

Interior volume [L]	Voltage	Option model	Version	Art.-No.
1020	200...230 V 1~ ph 50/60 Hz	Standard	KBFS1020-230V	9020-0372
	200...240 V 1~ ph 50/60 Hz	Standard	KBFS1020UL-240V	9020-0373

**TECHNICAL DATA**

Description	KBFS1020-230V <sup>1</sup>	KBFS1020UL-240V <sup>1</sup>
<b>Article Number</b>	<b>9020-0372</b>	<b>9020-0373</b>
<b>Performance Data Temperature</b>		
Temperature range [°C]	0...70	0...70
Temperature variation at 40 °C [± K]	0.3	0.3
Temperature fluctuation at 40 °C [± K]	0.1	0.1
Max. heat compensation at 40 °C [W]	550	550
<b>Performance Data Climate</b>		
Temperature range [°C]	10...70	10...70
Temperature variation at 25 °C and 60 % RH [± K]	0.3	0.3
Temperature variation at 40 °C and 75 % RH [± K]	0.3	0.3
Temperature fluctuation at 25 °C and 60 % RH [± K]	0.1	0.1
Temperature fluctuation at 40 °C and 75 % RH [± K]	0.1	0.1
Humidity range	20...80	20...80
Humidity fluctuation at 25 °C and 60 % RH	1,5 % RH	1,5 % RH
Recovery time after 30 seconds door open at 25 °C and 60 % RH [min]	11	11
Recovery time after 30 seconds door open at 40 °C and 75 % RH [min]	12	12
<b>Electrical data</b>		
Rated Voltage [V]	200...230	200...240
Power frequency [Hz]	50/60	50/60
Nominal power [kW]	2	2
Unit fuse [A]	16	16
Phase (Nominal voltage)	1~	1~
<b>Measures</b>		
Interior volume [L]	1020	1020
Net weight of the unit (empty) [kg]	379	379
Permitted load [kg]	150	150
Load per rack [kg]	45	45
Wall clearance back [mm]	100	100
Wall clearance sidewise [mm]	300	300
<b>Internal Dimensions</b>		
Width [mm]	976	976
Height [mm]	1250	1250
Depth [mm]	836	836
<b>Doors</b>		
Unit doors	2	2
<b>Housing dimensions not incl. fittings and connections</b>		
Width net [mm]	1250	1250
Height net [mm]	1925	1925
Depth net [mm]	1145	1145
<b>Environment-specific data</b>		
Sound-pressure level [dB(A)]	56	56
<b>Fixtures</b>		
Number of shelves (std./max.)	2/15	2/15

1 All technical data is specified for unloaded units with standard equipment at an ambient temperature of +22 °C ±3 °C and a power supply voltage fluctuation of ±10 %. The temperature data is determined in accordance to BINDER factory standard following DIN 12880, observing the recommended wall clearances of 10 % of the height, width, and depth of the inner chamber. Technical data refers to 100 % fan speed. All indications are average values, typical for units produced in series. We reserve the right to change technical specifications at any time.

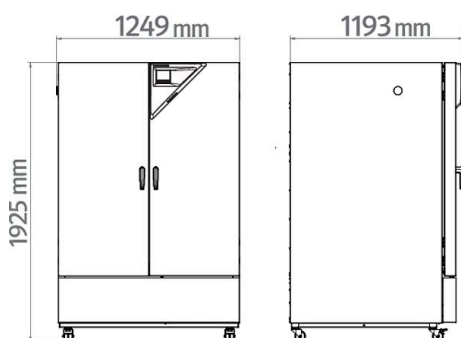
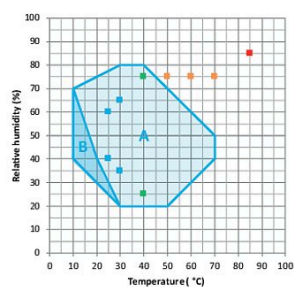
**DIMENSIONS incl. fittings and connections [mm]**

**CHARTS**

■ ICH Long term stability testing      A: Guaranteed condensation-free range  
■ Accelerated stability testing      B: Time-limited operation (max. 24 hours)  
■ ICH Stress testing  
■ Industrial THB testing (8p/8p)

Climate chart

**OPTIONS**

Designation	Description	*	Art.-No.
	left		
	30 mm	01	8012-2072
	50 mm	01	8012-2079
	100 mm	01	8012-2077
	right		
<b>Access port with silicone plug</b>	30 mm	01	8012-2071
	50 mm	01	8012-2078
	100 mm	01	8012-2076
	top		
	30 mm	01	8012-2073
	50 mm	01	8012-2074
	100 mm	01	8012-2075
<b>Calibration certificate, expanded</b>	for temperature and humidity; for extending the measurement in center of chamber to include another test value	-	8012-2066
<b>Calibration certificate, temperature</b>	temperature measurement incl. certificate and 27 measuring points at specified temperature	-	8012-2069
	temperature measurement incl. certificate, 15- 18 measuring points at specified temperature	-	8012-2068
	temperature measurement incl. certificate, 9 measuring points at specified temperature	-	8012-2067
<b>Calibration certificate, temperature and humidity</b>	Measurement in center of chamber at 25 °C / 60% RH or at specified test values	-	8012-2065
	temperature (according to DIN12880) and humidity measurement incl. certificate, 27 temperature measuring points and 1 humidity measuring point, at 25 °C / 60 % RH or at specified values	-	8012-2070
<b>Door lock</b>	lockable door handle	-	8012-2087

\* Notes › See last page

## ACCESSORIES

Designation	Description	*	Art.-No.
<b>APT-COM™ 4 BASIC-Edition</b>	for simple logging and documentation requirements with up to 5 networked units. version 4, BASIC edition	-	9053-0039
<b>APT-COM™ 4 GLP-Edition</b>	for working under GLP-compliant conditions. Measured values are documented in a tamper-proof way in line with the requirements of FDA Regulation 21 CFR 11. version 4, GLP edition	-	9053-0042
<b>APT-COM™ 4 PROFESSIONAL-Edition</b>	convenient unit and user management built on the BASIC edition. Suitable for networking up to 100 units. version 4, PROFESSIONAL edition	-	9053-0040
<b>BINDER PURE AQUA SERVICE</b>	System for preparation or complete desalination of tap water, complete set containing PURE AQUA 300 single-use cartridge, measuring device, and all necessary connecting parts	-	8012-0759
<b>BINDER PURE AQUA SERVICE, accessories</b>	Single-use, replacement cartridge for BINDER PURE AQUA System	-	6011-0165
<b>Convenient water supply</b>	Flexible positioning of the water container with magnetic holder, hose adapter for water container with practical quick coupling, and water stop function External, with magnetic holder	-	8012-1847
<b>LED light bars</b>	Basic set consisting of 2 pieces, attachment material, control unit for max. 4 light strips, 100-240 V, 50/60 Hz		
	Basic set 300, length 30 cm	-	8012-1107
	Basic set 500, length 50 cm	-	8012-1108
	Basic set 900, length 90 cm	-	8012-1109
	Expansion set consisting of 2 pieces, attachment material: clips. For expanding the basic set of light bars		
	Expansion set 300, length 30 cm	-	8012-1716
	Expansion set 500, length 50 cm	-	8012-1717
	Expansion set 900, length 90 cm	-	8012-1718
<b>pH-neutral detergent</b>	concentrated, for gentle remove of residual contaminants; 1 kg	-	1002-0016
<b>Qualification documents</b>	IQ/OQ documents – supporting documents for validation performed by customers, consisting of: IQ/OQ checklists incl. calibration guide and comprehensive unit documentation; parameters: temperature and humidity values		
	Digital in PDF format	-	7057-0002
	Hard copy inside folder	-	7007-0002
	IQ/OQ/PQ documents – supporting documents for validation performed by customers, according to customer requirements, PQ section added to qualification folder IQ/OQ; parameters: temperature and humidity values		
	Digital in PDF format	-	7057-0006
	Hard copy inside folder	-	7007-0006
<b>Rack</b>	stainless steel	-	8012-2052
<b>Rack accessories</b>	fasteners (1 set of 4) for additional security of racks	-	8012-0620
<b>Rack, reinforced</b>	stainless steel, with fasteners (1 set of 4)	-	8012-0968
<b>Shelf, perforated</b>	Stainless steel	-	8009-0792
<b>WLAN kit</b>	The kit contains a client bridge that establishes a wireless connection between BINDER units and APT-COM4, LIMS, or customer-specific software via an Ethernet interface. It provides an alternative solution in situations where units need to be positioned in locations without an on-site Ethernet connection. In secured networks, installation and configuration must be performed by the customer's IT service.	-	8500-0164

\* Notes › See last page

## SERVICES

Designation	Description	*	Art.-No.
<b>Installation services</b>			
Unit commissioning	Connect the unit to the customer-side connections (electricity, water, wastewater, gas), basic functions check, brief operating instructions. (excl.: unpacking, setup, controller instructions, programming, installation work)	05	DL10-0300
Unit instructions	Instruction regarding operating principle and basic functions of the unit, operation of the control electronics including programming	05	DL10-0700
<b>Maintenance contracts</b>			
<b>Maintenance services</b>			
BRONZE 3-year maintenance contract	Maintenance service as contractually agreed, visual inspection of mechanical and electrical components, check of control response, 20% discount on spare parts	05	DL20-0710

\* Notes › See last page

Designation	Description	*	Art.-No.
GOLD 3-year maintenance contract	Maintenance service as contractually agreed, visual inspection of mechanical and electrical components, check of control response, 20% discount on spare parts, testing of all key functions, replacement of wear parts, calibration of one temperature/humidity value, including certificate	05	DL20-0920
Maintenance	One-off maintenance service in accordance with maintenance schedule. Visual inspection of mechanical and electrical components, testing of all key functions. Calibration of a test temperature specified by the user in center of usable space without certificate	05	DL20-0400
SILVER 3-year maintenance contract	Maintenance service as contractually agreed, visual inspection of mechanical and electrical components, check of control response, 20% discount on spare parts, testing of all key functions, calibration of one test temperature specified by the user in the center of the usable space, without certificate	05	DL20-0820
<b>Calibration services</b>			
Temperature and humidity calibration	Expansion –Temperature and humidity calibration with 1 measuring point in center of chamber with 1 specified pair of values, including certificate	03, 04, 05	DL30-0302
	Temperature and humidity calibration with 1 measuring point in center of chamber with 1 specified pair of values, including certificate	03, 04, 05	DL30-0301
Temperature and humidity measurement according to DIN12880	Temperature measurement in accordance with DIN 12880 with 27 temperature measuring points and 1 humidity measuring point in center of chamber with a pair of values specified by the user, including certificate	03, 04, 05	DL30-0427
Temperature and humidity measurement, 18-1 measuring points	Temperature measurement with 18 temperature measuring points and 1 humidity measuring point in center of chamber with a pair of values specified by the user, including certificate	03, 04, 05	DL30-0318
Temperature and humidity measurement, 27-1 measuring points	Temperature measurement with 27 temperature measuring points and 1 humidity measuring point in center of chamber with a pair of values specified by the user, including certificate	03, 04, 05	DL30-0327
Temperature and humidity measurement, 9-1 measuring points	Temperature measurement with 9 temperature measuring points and 1 humidity measuring point in center of chamber with a pair of values specified by the user, including certificate	03, 04, 05	DL30-0309
<b>Validation services</b>			
Execution of IQ/OQ	Execution of IQ/OQ in accordance with qualification folder	05	DL42-0300
Execution of IQ/OQ/PQ	Execution of IQ/OQ/PQ in accordance with qualification folder	05	DL44-0500
<b>Warranty service</b>			
1-year warranty extension	The warranty is extended by 1 year from the delivery date, wear parts are excluded	-	DL50-0030

\* Notes › See last page

## NOTES

- 01 Condensation may occur in the area around the access port. Access ports may be placed in custom locations for an additional charge.
- 02 UL mark is not granted when this option is used.
- 03 Sensor calibration is performed in an accredited calibration laboratory.
- 04 Calibration is performed according to the BINDER factory standard.
- 05 Quoted prices do not include travel costs. Please refer to the chapter on BINDER Service for travel costs for your region. Quoted prices for services performed in Switzerland do not include a country-specific added fee (available on request).



**WolfLabs**

# WolfLabs Limited

[www.wolfabs.co.uk](http://www.wolfabs.co.uk)

Tel: 01759 301142

Fax: 01759 301143

[sales@wolfabs.co.uk](mailto:sales@wolfabs.co.uk)



Use the above details to contact us if this literature doesn't answer all your questions.

Pricing on any accessories shown can be found by keying the part number into the search box on our website.

The specifications listed in this brochure are subject to change by the manufacturer and therefore cannot be guaranteed to be correct. If there are aspects of the specification that must be guaranteed, please provide these to our sales team so that details can be confirmed.

