



› Mobile refrigeration

WAECO CoolFun	Thermoelectric coolers at an entry-level price	30 › 31
WAECO TropiCool	Thermoelectric high-tech coolers	32 › 37
WAECO BordBar	Thermoelectric coolers for the car	38 › 41
WAECO CombiCool	3-way absorption coolers	42 › 47
WAECO CoolFun	AC compressor cooler	48 › 49
WAECO CoolFreeze	Compressor coolers	50 › 67
WAECO CoolMatic	Compressor refrigerators	68 › 91
WAECO ColdMachine	Cooling units	92 › 103
WAECO CoolPower	Electronic accessories for cooling appliances	104 › 107



Thermoelectrics

Low-cost, light-weight, versatile

Inexpensive coolers for private and professional use

Thanks to their low weight, thermoelectric coolers are particularly easy to carry and transport. Their astonishing cooling capacity of up to 30°C below the ambient temperature is more than sufficient for most purposes, including car journeys, camping or picnics.

Thermoelectrics offer a welcome bonus: most of the coolers equipped with this wear- and maintenance-free technology can be used for both cooling and heating. Cost-efficient and reliable, thermoelectric energy is “just right” for small and medium-size portable coolers as well as for car coolers.

Here’s how thermoelectrics work

The thermoelectric principle is based on the fact that energy in the form of cold or heat is generated when the connection between different types of metals is linked to a direct current (DC) power source.

The heating or cooling function can be intensified using heat exchangers and air fans.



Active battery security
Prevents discharging of the vehicle battery below starting level



Heats & cools
Simple switch-over from cooling to heating mode thanks to thermoelectrics



Universal power supply
12/24 volts DC (cigarette lighter) or 230 volts AC (mains)



Cooling capacity
The appliance provides cooling in the specified temperature range



Great for picnics ...



... at work



... and for leisure activities

WAECO CoolFun



Low-cost portable coolers

WAECO CoolFun portable coolers are compact outside and spacious inside – thanks to the thermoelectric technology. The innovative design in cool blue is just right for spontaneous outdoor adventures.

Pages 30 – 31

WAECO TropiCool



Convenient high-tech coolers

WAECO TropiCool coolers provide powerful performance and perfect design. TC special electronics with soft-touch operating panel and power-save mode. 12/24/230-volt connection as standard (TC-07: 12/230 volts only).

Pages 32 – 37

WAECO BordBar



Compact coolers for the car

Travelling is fun with a WAECO BordBar on board: cool snacks and drinks in easy reach on the front passenger seat or one of the seats in the rear. Sufficient capacity for picnics, breakfast in the office and more.

Pages 38 – 41

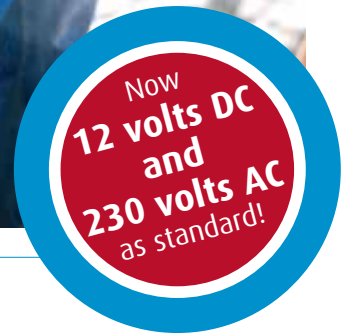

Pit stop at bargain price

Affordable coolers with AC/DC connection and astonishing extras

The best breaks are blue: WAECO CoolFun coolers are light and handy, yet they have a great deal to offer. Cheerfully blue in colour and compact in design, they are surprisingly roomy inside – large enough to accommodate even tall bottles.

The “trick” is that the **innovative thermoelectric system** takes up little space while providing impressive functionality. It will not only bring the temperature down to +5°C, but also raise it to +70°C if required.

Thanks to the **integrated 230-volt mains adapter** you can run your cooler from the mains at home or the cigarette lighter of your vehicle. The integrated priority

circuit for 230 volts reduces the strain on the vehicle battery to a minimum.

The **power-save circuit** of the WAECO CoolFun CD-32 allows for **maximum economy**.

Have a “blue” break – WAECO CoolFun adds pleasure to your break – in your free time and at work.

WAECO CoolFun CD-22

4.02

NEW

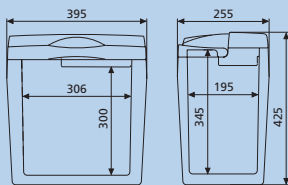

Gross capacity	approx. 22 litres
Voltage	12/230 volts DC/AC
Average power consumption	48 watts
Temperature range	In the cooling mode: up to 20°C below the ambient temperature, in the heating mode: interior temperature limited by thermostat at +65°C
Insulation	Polyurethane full-foam insulation
System	Wear-free thermoelectrics (Peltier system)
Colour	Blue/white
Weight	4.8 kg
Quality features	Brushless fan, vertical space for standing 1.5-litre bottles, dynamic interior ventilation, can be switched to cold/warm, practical recessed grip in the lid, ready for connection to 230 volts
Scope of delivery	Additional insulating lid
Test marks	TÜV/GS, e-approved according to 95/54/EC (EMC guidelines for vehicles)
Product	Ref. No.
CoolFun CD-22	CD-22-AC



Up to **20°C** below ambient temperature



Up to **65°C** in the heating mode



12/230 volts

With additional insulating lid

WAECO CoolFun CD-32

4.02

NEW

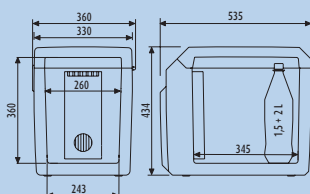

Gross capacity	approx. 32 litres
Voltage	12/230 volts DC/AC
Average power consumption	60 watts at 12 volts, 70 watts at 230 volts
Temperature range	In the cooling mode: 5°C to 15°C (up to 25°C below the ambient temperature); in the heating mode: 55°C to 70°C
Insulation	Polyurethane full-foam insulation
System	Wear-free thermoelectrics (Peltier system), cold transmission to the interior by dynamically ventilated aluminium heat exchanger, heat dissipation to the outside with high-performance heat exchanger and brushless, wear-free fan
Material	Sturdy injection-moulded parts
Colour	Blue/white
Weight	approx. 8.0 kg
Quality features	Purpose-built, intelligent power-save circuit, interior temperature continuously variable with slide switch from +5°C to +15°C or +55°C to +70°C, ON/OFF and cold/warm switches on membrane keypad, vertical space for 2-litre returnable bottles, can be used as a box or upright fridge, ready for connection to 12/230 volts with priority for 230 volts
Test marks	TÜV/GS, e-approved according to 95/54/EC (EMC guidelines for vehicles)
Product	Ref. No.
CoolFun CD-32	CD-32-AC



Up to **25°C** below ambient temperature



Up to **70°C** in the heating mode



12/230 volts

With power-save circuit

HIGHLY EFFECTIVE INSULATION

TropiCool coolers owe their outstanding refrigeration performance not only to the intelligent technology but also to a highly effective insulation.

THE MAGNETIC SWITCH

To prevent energy loss, the interior fan is switched off when you open the box, and on again when you close it. The magnetic switch takes care of that.



UNIVERSAL FIXING KIT

A universal fixing kit is available for safe fastening of TropiCool coolers TC-14FL, TC-21FL and TC-35FL in vehicles (p. 36).

HEAT EXCHANGER AND HIGH-PERFORMANCE Peltier ELEMENT

A powerful duo: heat exchanger and high-performance Peltier element, both tailor-made for the TropiCool series. The result: a remarkable cooling capacity up to 30°C below the ambient temperature. (All models except TC-07).

DYNAMIC VENTILATION WITH WEAR-RESISTANT INTERIOR- AND EXTERIOR FANS

WAECO TropiCool coolers owe their extremely long service life to the brushless, wear resistant fans. The dynamic fans also improve the cooling performance. They ensure that the cold air is evenly spread in the interior of the coolers and guarantee efficient heat dissipation to the outside.

12/24/230-VOLT CONNECTION AVAILABLE AS STANDARD (DC/AC)

The TropiCool coolers TC-14FL, TC-21FL and TC-35FL can also be operated in vehicles with 24-volt battery. Whether 12 volts DC, 24 volts DC or 230 volts AC – the intelligent electronic system recognises automatically which voltage is applied. The priority circuit makes sure that power is drawn from the 230-volt mains to save the battery.



12/24/230 volts



The detachable lid enables fast access to the contents – even in confined spaces.

Light-weight and easy to carry with the practical fold-out carrying handle



230 volts AC



12/24 volts DC

WAECO TropiCool coolers provide plug & play convenience, no matter whether you've got a 12/24-volt or 230-volt power source. The DC + AC feature is available as standard!

Innovative technology for more cooling comfort

High-tech inside: intelligent power-save circuit and TC special electronics

The intelligent power-save circuit

TropiCool coolers are great energy savers. As soon as the power is on, they **cool at full capacity** to reach the desired temperature. Once this has been achieved, they switch automatically to the **power-save mode**. In this mode, the Peltier element draws very little power. This gives rise to an insulation bridge that prevents heat from flowing into the cooling compartment.

Example: a conventional cooler operated in the 12-volt mode consumes between 4 and 4.5 Ah per hour to achieve an interior temperature of 5°C at an ambient temperature of 25°C, the TC-21FL makes do with just 2.1 Ah per hour.

High-tech inside: TC special electronics with LED temperature readout

TropiCool coolers provide refrigeration up to 30°C below the ambient temperature and heating up to 65°C. Using the soft-touch operating panel, you can set the desired temperature in seven stages each: from 1°C to 15°C in the cooling mode, or from 50°C to 65°C in the heating mode. The memory function saves the last set parameters.*

* All models except TC-07



- › ON/OFF
- › Cold/warm switch
- › LED indicator
- › Memory function
- › Temperature regulation: 7 stages each for cooling and heating



Cool enjoyment outdoors

Whether on the road, on a picnic or at home on the terrace, WAECO TropiCool coolers provide you with cool snacks and drinks.

Mobility, safety and convenience are the hallmarks of the tried and tested series. High-tech thermoelectrics, enabling an outstanding cooling capacity up to 30°C below the ambient temperature, team up with valuable features and functions: 12/24/230 V DC/AC available as standard, individual temperature regulation with LED

readout, memory function, to name but a few. At the touch of a button, the coolers (1°C to 15°C) can be turned into warmer boxes (50°C to 65°C). WAECO TropiCool generation has arrived to redefine the convenience standards of mobile refrigeration.



WAECO TropiCool – powerful luxury



TC-07

TC-35FL

TC-14FL

TC-21FL



WAECO TROPICOOOL TC-07: THE SMALL CLASSIC

Planning a short trip for just the two of you? Then the TC-07 is the ideal companion. With its 7-litre capacity, it affords cooling up to 25°C below ambient and will even heat up to 65°C. Easy to carry with the practical shoulder strap, it follows you wherever you go. You can use it in the car as well as at home.

Each unit incorporates a 230-volt mains adapter!



WAECO TROPICOOOL TC-14FL: THE COMPACT ALL-ROUNDER

The TC-14FL has all the hallmarks of the WAECO TropiCool generation: TC special electronics, soft-touch panel, LED indicators, memory function. New design features include the space saving flat lid and the convenient “grab & go” handle. Despite its considerable 14-litre capacity, this versatile cooler is still compact and handy to carry.

12/24/230 volts DC/AC available as standard.



WAECO TROPICOOOL TC-21FL: THE FAMILY BOX

With a cool capacity of 21 litres, the TC-21FL will easily take all you need for a long car journey or a wholesome family picnic. Enhanced cooling comfort is provided by latest generation TC special electronics. The detachable flat lid enables fast and convenient access, even in confined spaces.

12/24/230 volts DC/AC available as standard.



WAECO TROPICOOOL TC-35FL: BIG LUXURY

NEW!

All the freedom you need: the TC-35FL offers a generous capacity of 35 litres. Ready for connection to 12/24 volts DC and 230 volts AC, it can be used simply everywhere. CF special electronics give you the extra comforts of individual temperature regulation, LED temperature readout and memory function.

12/24/230 volts DC/AC available as standard.

WAECO TropiCool TC-07

4.01

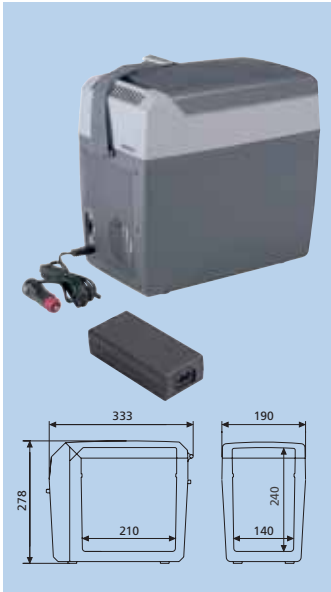

Gross capacity	approx. 7 litres
Voltage	12/230 volts DC/AC
Average power consumption	36 watts
Temperature range	Cooling mode: approx. 5°C (up to 25°C below ambient temperature) heating mode: approx. +65°C
Insulation	Polyurethane full-foam insulation
System	Wear-free thermoelectrics (Peltier system), cold/heat transmission to the interior through coated aluminium container, heat dissipation to the outside by brushless, wear-free fan
Colour	Dark grey/pale grey
Weight	approx. 2.8 kg
Quality features	Temperature regulation for cooling and heating with fixed point thermostats, ready for connection to 230 volts
Scope of delivery	Shoulder strap, 12-volt connection cable and 230-volt mains adapter included in the delivery kit
Test marks	TÜV/GS, e-appr. to 95/54/EC (EMC guidelines for vehicles)
Product	Ref. No.
TropiCool TC-07	TC-07UG-12/230



Up to **25°C** below ambient temperature



Up to **65°C** in the heating mode



12/230 volts

WAECO TropiCool TC-14FL

4.01



Gross capacity	approx. 14 litres
Voltage	12/24 volts DC and 230 volts AC
Average power consumption	60 watts at 12 V, 75 watts at 24 V, 70 watts at 230 V
Temperature range	Cooling: 1°C to 15°C (up to 30°C below ambient temperature); heating: 50°C to 65°C
Insulation	Polyurethane full-foam insulation
System	Wear-free thermoelectrics (Peltier system), cold transmission to the interior by dynamically ventilated aluminium heat exchanger, heat dissipation to the outside with high-performance heat exchanger and brushless, wear-free fan
Material	Sturdy, injection moulded parts
Colour	Dark grey/pale grey
Weight	approx. 5.0 kg
Quality features	TC special electronics, 7-stage electronic thermostat with LED indicators, memory function, ON/OFF and cold/warm option activated with soft-touch operating panel, intelligent power-save circuit; integrated mains supply unit with priority circuit, outstanding cooling performance, magnetic switch to deactivate the interior fan when the box is opened, detachable lid with magnetic lock, sturdy, fold-away handle
Test marks	TÜV/GS, e-approved according to 95/54/EC (EMC guidelines for vehicles)
Product	Ref. No.
TropiCool TC-14FL	TC-14FL-AC
Optional extra: universal fixing kit	UFK-T



Up to **30°C** below ambient temperature



Up to **65°C** in the heating mode



12/24/230 volts

TC special electronics

Universal fixing kit

4.01



For TropiCool TC-14, TC-21, TC-35: fastening of TropiCool coolers in vehicles.	
Material	Powder-coated metal
Colour	Black
Scope of delivery	Two base plates, two adjustable straps, set of screws
Product	Ref. No.
Universal fixing kit	UFK-T



WAECO TropiCool TC-21FL

4.01



Gross capacity	approx. 21 litres
Voltage	12/24 volts DC and 230 volts AC
Average power consumption	60 watts at 12 volts 75 watts at 24 volts, 70 watts at 230 volts
Temperature range	Cooling mode: 1°C to 15°C (up to 30°C below the ambient temperature); heating mode: 50°C to 65°C
Insulation	Polyurethane full-foam insulation
System	Wear-free thermoelectrics (Peltier system), cold transmission to the interior by dynamically ventilated aluminium heat exchanger, heat dissipation to the outside with high-performance heat exchanger and brushless, wear-free fan
Material	Sturdy, injection-moulded parts
Colour	Dark grey/pale grey
Weight	approx. 6.0 kg
Quality features	TC special electronics, 7-stage electronic thermostat with LED indicators, memory function, ON/OFF and cold/warm option activated with soft-touch operating panel, intelligent power-save circuit; integrated mains supply unit with priority circuit, outstanding cooling performance, magnetic switch to deactivate the interior fan when the box is opened, detachable lid with magnetic lock, sturdy, fold-away handle, vertical space for 2-litre bottles, adjustable grid divider
Test marks	TÜV/GS, e-approved according to 95/54/EC (EMC guidelines for vehicles)
Product	Ref. No.
TropiCool TC-21FL	TC-21FL-AC
Optional extra: universal fixing kit	UFK-T



Up to **30°C** below ambient temperature



Up to **65°C** in the heating mode



12/24/230 volts

TC special electronics



WAECO TropiCool TC-35FL

4.01



Gross capacity	approx. 35 litres
Voltage	12/24 volts DC and 230 volts AC
Average power consumption	60 watts at 12 volts, 75 watts at 24 volts, 70 watts at 230 volts
Temperature range	Cooling mode: 1°C to 15°C (up to 30°C below the ambient temperature); heating mode: 50°C to 65°C
Insulation	Polyurethane full-foam insulation
System	Wear-free thermoelectrics (Peltier system), cold transmission to the interior by dynamically ventilated aluminium heat exchanger, heat dissipation to the outside with high-performance heat exchanger and brushless, wear-free fan
Material	Sturdy, injection moulded parts
Colour	Dark grey/pale grey
Weight	approx. 8.0 kg
Quality features	TC special electronics, 7-stage electronic thermostat with LED indicators, memory function, ON/OFF and cold/warm option activated with soft-touch operating panel, intelligent power-save circuit. Integrated mains supply unit with priority circuit, outstanding cooling performance, magnetic switch to deactivate the interior fan when the box is opened, detachable lid with magnetic lock, sturdy, fold-away handle, vertical space for 2-litre bottles, adjustable grid divider
Test marks	TÜV/GS, e-approved according to 95/54/EC (EMC guidelines for vehicles)
Product	Ref. No.
TropiCool TC-35FL	TC-35FL-AC
Optional extra: universal fixing kit	UFK-T

NEW



Up to **30°C** below ambient temperature



Up to **65°C** in the heating mode



12/24/230 volts

Jumbo cooler for campers, travellers and truckers

TC special electronics





NEW!
Easy to fit –
replaces
the middle
rear seat

A perfect arrangement

All fresh and in the right place

An impressive **gross capacity of 28 litres** provides ample space for everything you need to keep your family perfectly happy on board: delicious snacks and dairy products, cool drinks (1-litre bottles stored upright!) and many more.

Everything is ready at hand while travelling: the **WAECO BordBar BB-28** is available with a matching fixing kit that gives **slide- and tilt-proof installation** in place of the middle back rear of larger vehicles.



A cool journey: ample space for fresh snacks and cool drinks ... ready at hand!



The happy medium: the cooler is fixed safe and sound in place of the middle rear seat.



Childs' play, yet firm as rock: just click the cooler into the existing seat slides.

WAECO BordBar BB-28

4.08

NEW

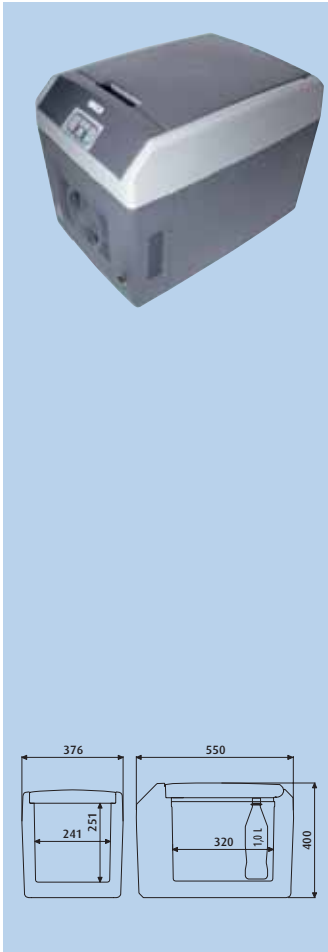

Gross capacity	approx. 28 litres
Voltage	12 volts DC
Average power consumption	48 watts
Temperature range	In the cooling mode: up to 30°C below ambient temperature, in the heating mode: interior temperature limited by thermostat at +65°C
Insulation	Polyurethane full-foam insulation
System	Wear-free thermoelectrics (Peltier system), cold transmission to the interior by dynamically ventilated aluminium heat exchanger, heat dissipation to the outside with high-performance heat exchanger and brushless, wear-free fan
Material	Sturdy, injection-moulded parts in PP
Colour	Dark grey/pale grey
Weight	approx. 8.5 kg
Quality features	Soft-touch operating panel with LED indicators, memory function, cold/warm switch, detachable lid, crash-proof lid lock, adjustable grid divider, integrated recessed grips, vertical space for 1-litre bottles, Active Battery Security (ABS), 2 integrated bottle holders
Test marks	TÜV/GS, e-approved according to 95/54/EC (EMC guidelines for vehicles)

Product	Ref. No.
BordBar BB-28	BB-28-12
Optional extras:	
Fixing kit for Renault Scenic - 06/03	FK-SCE1
Fixing kit for VW Touran	FK-TOU
Mains adapter 230 V > 12 V	EPS-817U



Up to **30°C** below ambient temperature



Up to **65°C** in the heating mode



Active Battery Security

Extra comfort and convenience with soft-touch operating panel

THE BORDBAR BB-28 IS TECHNICALLY SOPHISTICATED ...

... yet using it is child's play: switch to **cooling or heating**, **memory-function**, **Active Battery Security (ABS)** ... the **soft-touch operating panel** with LED controls makes it comfortable and easy to use.

The **variable partition** inside and two integrated **bottle holders** enhance the BordBar's functional quality.

Perfect down to the last detail



Ready to use within seconds: just plug the 12-volt plug into the cigarette lighter socket



Sophisticated technology made simple and safe: clearly designed soft-touch operating panel with LED indicators



Open the lid, find the bottle in place: two integrated bottle holders under one cover ... as handy as can be!



NEW!
Easy to fit –
replaces
a seat

Bar pleasures on the move

Strong, sturdy, cool: the WAECO BordBar BB-32

The **WAECO BordBar BB-32** is the “sitting giant” among vehicle coolers. Its elegant housing disguises an astonishing **32-litre gross capacity**. The BordBar is ideal for installation in vans and MPVs, where it replaces a seat in the back of the vehicle.

Its performance and convenience leave nothing to be desired: the **high-quality soft-touch operating panel** with LED controls makes it easy to **set the desired temperature**, the **memory-function** saves the last setting.

The storage space inside is adapted to your needs with a **variable partition** and can even accommodate 1-litre bottles upright.

Perfect down to the last detail



At the touch of a button, the LED display shows the preset or – respectively – the current temperature.



Just connect it to the cigarette lighter socket – the BordBar heats or cools as required.



Inner riches: crash-proof lid lock and large, variable interior

WAECO BordBar BB-32

4.08

NEW

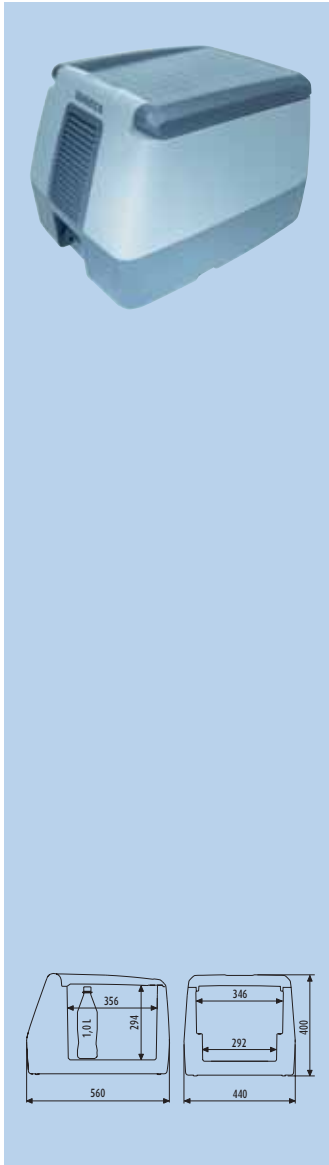

Gross capacity	approx. 32 litres
Voltage	12 volts DC
Average power consumption	48 watts
Temperature range	In the cooling mode: up to 25°C below ambient temperature, in the heating mode: interior temperature limited by thermostat at +65°C
Insulation	Polyurethane full-foam insulation
System	Wear-free thermoelectrics (Peltier system), cold transmission to the interior by dynamically ventilated aluminium heat exchanger, heat dissipation to the outside with high-performance heat exchanger and brushless, wear-free fan
Material	Cabinet: PP, lid: PE
Colour	Dark grey/pale grey
Weight	approx. 9.0 kg
Quality features	Soft-touch operating panel with LED indicators, memory function, cold/warm switch, detachable lid, crash-proof lid lock, adjustable grid divider, integrated recessed grips, vertical space for 1-litre bottles, Active Battery Security (ABS), 2 integrated bottle holders
Test marks	TÜV/GS, e-approved according to 95/54/EC (EMC guidelines for vehicles)

Product	Ref. No.
BordBar BB-32	BB-32-12
Optional extras:	
Fixing kit for Ford Galaxy, Seat Alhambra, VW Sharan	FK-SAG
Fixing kit for Renault Espace 11/96 - 10/02	FK-ESP1
Fixing kit for Renault Espace 11/02 -	FK-ESP2
Mains adapter 230 V > 12 V	EPS-817U



Up to **25°C** below ambient temperature



Up to **65°C** in the heating mode



Active Battery Security

Extra comfort and convenience with soft-touch operating panel





Absorption technology

Cooling with power and gas

3-way refrigeration: all the freedom you need

Absorption coolers are truly mobile, giving camping enthusiasts all the freedom they need. **Gas operation** in a remote fjord, **convenient 230-volt hook-up** at the campsite, power supply from the **cigarette lighter socket in cars or motorhomes** – anything is possible!

Switch-over from one energy mode to another in a trice! Whether gas, 12 or 230 volts, the refrigeration system can be flexibly adjusted to suit your needs – up to 30°C below the ambient temperature.

Gas operation

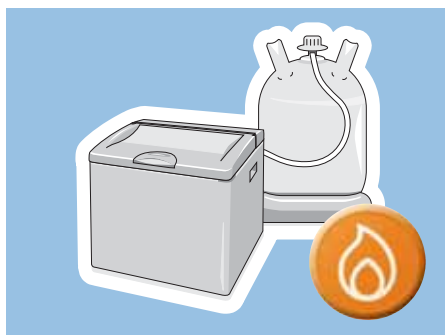

230-volt connection

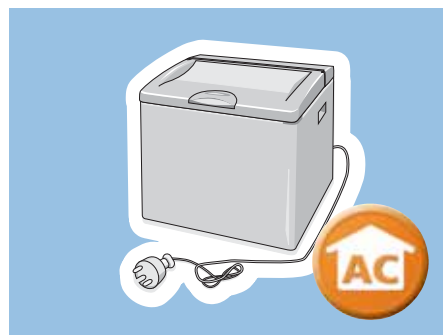

12-volt connection

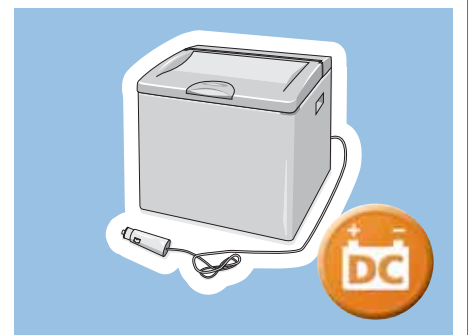



For outdoors ...



... and camping

ABSORPTION REFRIGERATION

Here's how absorption refrigeration works: a concentrated ammonia solution is heated in a hermetic system and driven off as vapour. The pressurised ammonia gas is then liquefied in a condenser and supplied with hydrogen. As a result, it evaporates and, in the process, extracts heat from the food storage space.

The ammonia gas then enters the absorber where it is reabsorbed in a weak solution of ammonia. Finally, the saturated solution flows back to the boiler where the whole cycle starts again. The boiler can be powered by either gas, 12 or 230 volts.

WAECO CombiCool CAB-40/-55



Portable 3-way absorption coolers

WAECO CombiCool coolers are robust, spacious and versatile. Featuring high-performance absorption technology, they can be operated on 12 volts, 230 volts or gas – which means simply everywhere! Ideal for camping and caravanning.

Pages 34 – 35

WAECO CombiCool CAS-60



3-way absorption refrigerator

The WAECO CombiCool absorption refrigerator also offers 3-way refrigeration with 12 volts, 230 volts and gas. A universal fridge with a functional and spacious interior for food, drinks and ice cubes.

Pages 36 – 37

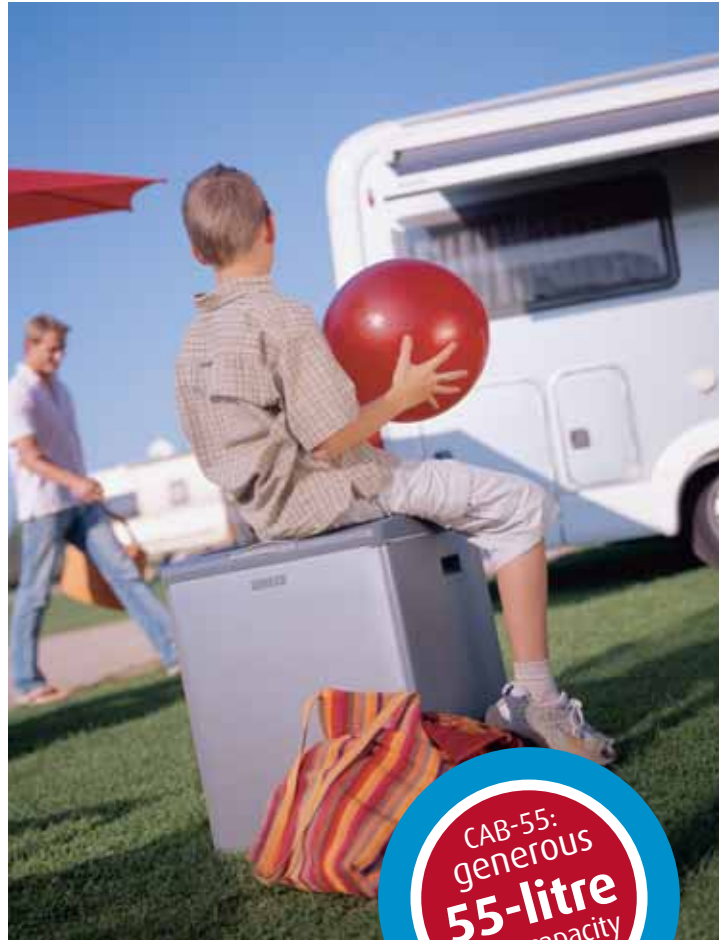
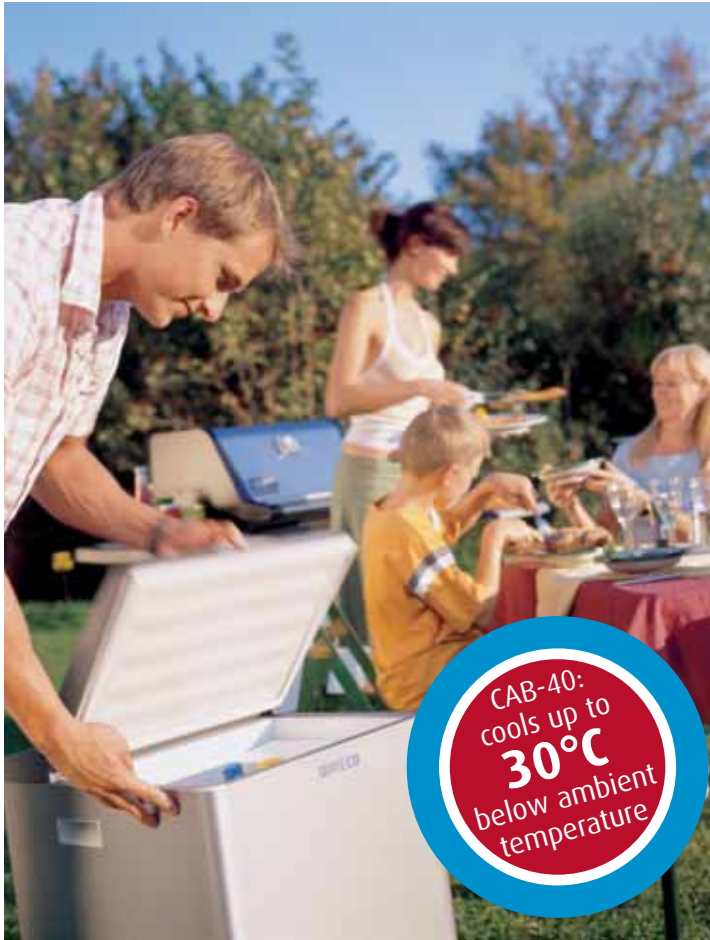

For camping and leisure

Absorption technology – cooling with power and gas

One cooling appliance for all situations – this is how the smart CombiCool absorption coolers are most aptly described. They provide a generous capacity of 40 or 55 litres respectively, for snacks and drinks which can be cooled with either gas or electricity (12 volts DC or 230 volts AC.)

While you are on the road in your car or motorhome, the energy comes from the vehicle battery via the cigarette

lighter. At your destination, you can switch over to either gas or 230 volts.

Their **flexibility, functional design** and **robust cabinet** have made our CombiCool absorption coolers a real success – highly appreciated by motorhome owners, camping and outdoor enthusiasts alike.

Perfect down to the last detail



Regulators for gas and electric operation



Evaporator with recessed space for ice cube tray



Organises the contents: detachable wire basket (CAB-55)



WAECO CombiCool CAB-40 3-way absorption cooler

4.16

NEW

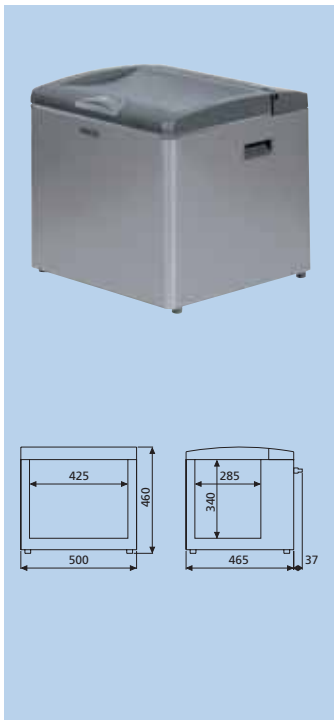

Gross capacity	40 litres
Energy supply/consumption	230 V AC/50 Hz/100 W/0.43 A, 12 V DC/100 W/8.33 A, liquefied petroleum gas 30 or 50 mbar/category I _{3B/P} / 13 g/h max. In Germany, the 30-mbar model may only be used in combination with the ASK-30 connection set.
Cooling capacity	Up to 30°C below ambient temperature
Insulation	Full foam insulation in CFC-free polyurethane foam
Weight	approx. 16 kg
Material	Cabinet in coated sheet steel, lid and cooling unit cover in plastic
Colour	Cabinet: silver-grey, lid and cooling unit cover: dark grey
Quality features	Piezo ignition, thermostat regulation in the 230-volt mode, continuously variable flame regulation in the gas mode, ice cube tray, vertical space for 2-litre bottles
Test marks	Certified to European Gas Appliance Directive 90/396/EEC, e-approved to 95/54/EC (EMC vehicle guidelines)
Products	Ref. No.
CombiCool CAB-40 (30 mbar)	CAB-40-PB30
CombiCool CAB-40 (50 mbar)	CAB-40-PB50
Connection set for the 30-mbar model, essential for use in Germany	ASK-30



Up to **30°C** below ambient temperature



12/230 volts



Gas

40-litre gross capacity!

WAECO CombiCool CAB-55 3-way absorption cooler

4.16

NEW

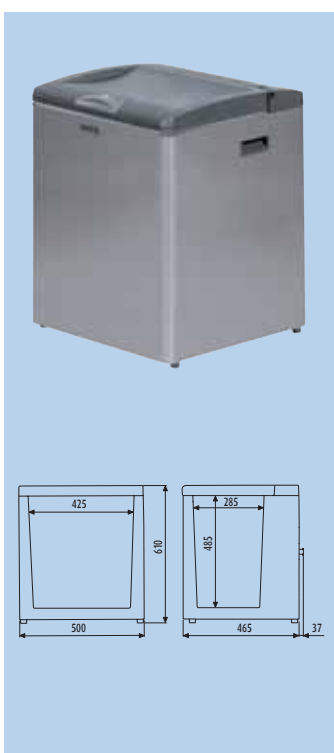

Gross capacity	55 litres
Energy supply/consumption	230 V AC/50 Hz/100 W/0.43 A, 12 V DC/100 W/8.33 A, liquefied petroleum gas 30 or 50 mbar/category I _{3B/P} / 19 g/h max. In Germany, the 30-mbar model may only be used in combination with the ASK-30 connection set.
Cooling capacity	Up to 25°C below ambient temperature
Insulation	Full foam insulation in CFC-free polyurethane foam
Weight	approx. 20 kg
Material	Cabinet in coated sheet steel, lid and cooling unit cover in plastic
Colour	Cabinet: silver-grey, lid and cooling unit cover: dark grey
Quality features	Piezo ignition, thermostat regulation in the 230-volt mode, continuously variable flame regulation in the gas mode, ice cube tray, detachable wire basket, vertical space for 2-litre bottles
Test marks	Certified to European Gas Appliance Directive 90/396/EEC, e-approved to 95/54/EC (EMC vehicle guidelines)
Products	Ref. No.
CombiCool CAB-55 (30 mbar)	CAB-55-PB30
CombiCool CAB-55 (50 mbar)	CAB-55-PB50
Connection set for the 30-mbar model, essential for use in Germany	ASK-30



Up to **25°C** below ambient temperature



12/230 volts



Gas

55-litre gross capacity!

With detachable wire basket



WAECO CombiCool absorption refrigerator

Powered by a dream team trio: AC, DC and gas

Mobile, convenient, versatile: the WAECO CombiCool absorption refrigerator is a cool tip for camping and caravan enthusiasts. Its particular strength is its ability to transform three energy sources (gas, 12 volts or 230 volts) into amazing cooling power.

So flexible you can easily take it to wherever you need a refrigerator: to the motorhome, the awning, the home terrace, or down to the beach.

Absorption refrigeration works noiselessly. Therefore, WAECO CombiCool won't disturb anyone's sleep, even if it's placed close to a bed. Enjoy your sleep and have a great day starting with a fresh breakfast!





WAECO CombiCool CAS-60 3-way absorption refrigerator

4.16

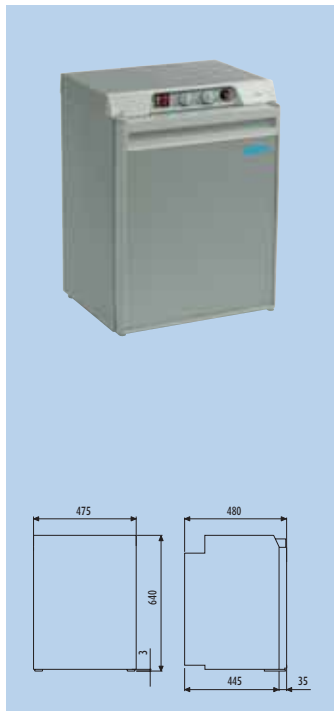

Gross capacity	56 litres
Energy supply/consumption	230 V AC/50 Hz/100 W/0.44 A, 12 V DC/100 W/8.3 A liquefied petroleum gas 30 or 50 mbar/category I _{3B/P} / 19 g/h (max.) In Germany, the 30-mbar model may only be used in combination with the ASK-30 connection set.
Cooling capacity	Up to 25°C below ambient temperature
Insulation	Full foam insulation in CFC-free polyurethane foam
Weight	approx. 20.5 kg
Material	Cabinet in coated sheet steel, grip and switches in plastic
Colour	Silver/pale grey
Quality features	Piezo ignition, automatic condensation drainage, thermostat regulation in the 230-volt mode, continuously variable flame regulation in the gas mode, practical door lock with vent option, 2 ice cube trays
Text marks	Certified to European Gas Appliance Directive 90/396/EEC, e-approved to 95/54/EC (EMC vehicle guidelines)
Products	Ref. No.
CombiCool CAS-60	CAS-60-12/PB30
CombiCool CAS-60	CAS-60-12/PB50
Connection set for the 30-mbar model, essential for use in Germany	ASK-30



Up to 25°C below ambient temperature



12/230 volts



Gas

One appliance for three energy sources:
12 volts,
230 volts or gas

ROBUST ALL-ROUND FRIDGE FOR MOBILE USE

The **WAECO CombiCool CAS-60** comes in a **robust casing** to withstand the rigours of mobile use.

On top of that, this functional fridge has a lot of inner riches. For example, a generous **56-litre capacity** for food and drinks plus an adjustable door rack with room for 1.5-litre bottles. It can even make ice cubes for a long, cool drink after a day outdoors. Two **ice-cube trays** are included in the delivery kit.

Perfect down to the last detail



Door lock with vent option



Versatile interior: the door racks can be adjusted in height and width (room for bottles up to 1.5 litres)



For extra comfort and convenience: two ice cube trays, adjustable grid shelves



Switches for battery/mains power and Piezo ignition, turning knobs for gas and power supply, gas ON indicator



For camping, home and leisure

Powerful compressor cooler for 230 volts

This portable fridge not only cools your drinks, it also keeps frozen food reliably "on ice". The temperature is continuously variable from +10°C to -15°C.

The WAECO CoolFun CK-40D compressor cooler can be a genuine alternative to an absorption unit. Ready for operation on 12 volts, 230 volts or gas, absorption coolers are very flexible in use. However, their cooling performance will largely depend on the ambient temperature. The WAECO CoolFun CK-40D, by contrast, provides an extraordinary energy efficiency even at high outside temperatures. It is a safe bet for those looking for a 230-volt portable cooler with excellent performance and low power consumption.

The CoolFun CK-40D is not only extremely powerful and versatile but also a great energy saver. This is due to the innovative compressor technology employed as well as to the reinforced cabinet that gives an extra insulating effect.



WAECO CoolFun CK-40D

4.16



Gross capacity	approx. 40 litres
Voltage	230 volts AC
Average power consumption	65 watts
Average running time	20% at 20°C ambient temperature, 60% at 32°C ambient temperature, both at 5°C interior temperature
Temperature range	+10°C to -15°C
Insulation	CFC-free polyurethane foam
System	Powerful AC compressor, aluminium rollbond evaporator, statically ventilated wire condenser
Material	Cabinet in coated sheet steel, base and upper components in plastic
Colour	Silver/anthracite
Weight	approx. 22 kg
Quality features	Refrigeration and deep-freezing, electronic thermostat with digital temperature readout, wear-free refrigeration cycle, lid with all-round rubber seal and magnetic lock, quick-chill functionality thanks to powerful AC compressor and extra-strong insulation
Test marks	TÜV/GS



Temperature range
+10°C to -15°C

NEW!
With digital
temperature readout

Powerful
AC compressor

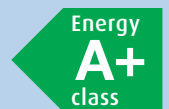

at +5°C
interior temperature
and 25°C
ambient temperature

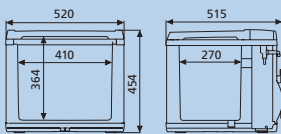

Product	Ref. No.
CoolFun CK-40D, 230 volts	CK-40D-230

COOLER AND FREEZER ALL IN ONE: FOR INDOORS OR OUT, EVERYDAY AND HOLIDAY

The multi-purpose cooler/freezer CoolFun CK-40D is a highly **efficient quick chiller**. It comes with a **powerful AC compressor**, **extra-strong insulation** and **an all-round rubber seal**. The cooling temperature is continuously variable from +10°C to -15°C. Wear-free refrigeration cycle. Ready for connection to 230 volts.

Perfect down to the last detail



NEW: easy-to-read digital temperature display



Room for it all: even for 2-litre bottles standing upright



Safe storage of sensitive food: deep-freezing up to -15°C