

# ● Shimadzu UV-VIS Spectrophotometers ●

## UV-2450

## UV-2550

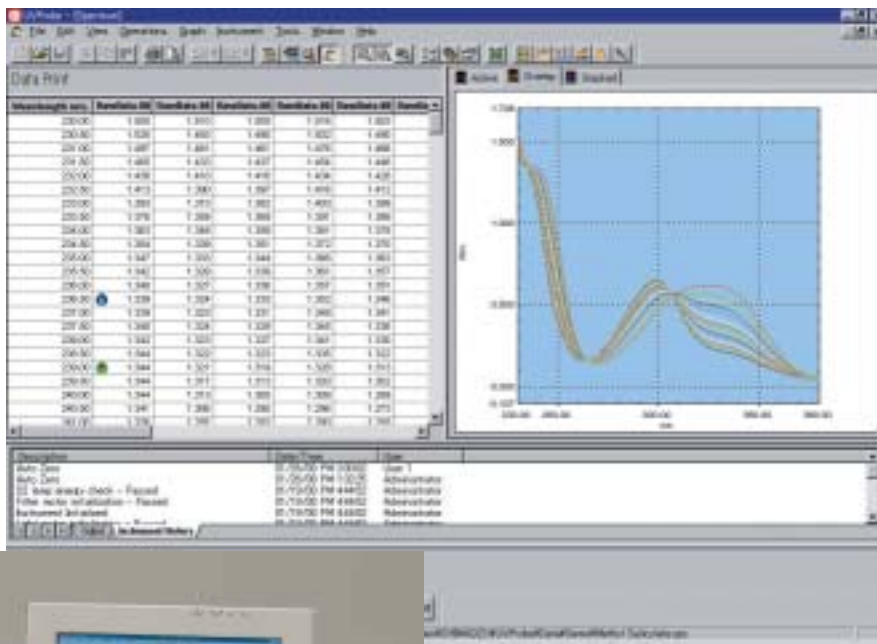

# A new history for spectropho

**Ultra low stray light in the world's best  
double monochromator instrument**

## *UV-2550*

**High performance  
single monochromator instrument**

## *UV-2450*

Following their introduction in 1995, the world's highest performance, easy-to-use Shimadzu UV-2401/2501 spectrophotometers are now even more powerful with the addition of the world's most advanced software. These spectrophotometers have made their entrance to greet the new century.

### **Low stray light**

The UV-2550, with its DDM (double blazed grating, double monochromator) design, provides a high energy throughput optical system with ultra low stray light. The UV-2450, the single monochromator version of the UV-2550, achieves 0.015% stray light even with its simpler optical system.

### **High Performance**

Both instruments offer outstanding cost performance in their ability to provide UV-VIS spectral analysis of wide ranging samples, including organic and inorganic compounds, biological samples like DNA and enzymes, as well as special measurements on optical materials.

### **Windows NT Compatible**

Operating under the Windows NT environment, the new generation UV Probe software is provided as standard. UVProbe incorporates the latest multitasking and report generation functionality, including network support, enabling measurement assistance among colleagues and effective presentation of precious data.



# tometers in the new century

**Shimadzu's highly reputed spectrophotometers combined with the most up-to-date, superb software achieve high throughput and increased productivity. With the newly developed 8/16 cell positioner system, up to 16 specimens can be analyzed automatically.**

## **Analysis of multiple trace samples**

The 8/16 micromulti-cell permits selection among 4 possible combinations with sample capacities of 50 $\mu$ L and 100 $\mu$ L. And, either the normal type or the constant-temperature controlled type cell holder may be selected.

NOTE) Both the cell holder and the multi-cell are optional accessories.

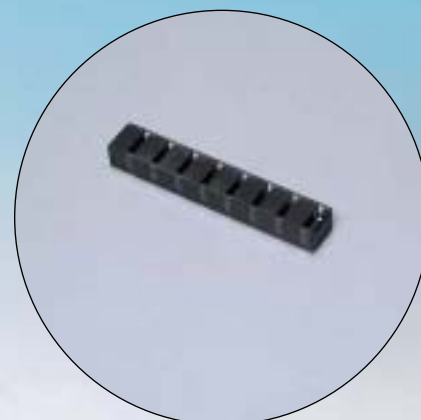

(100 $\mu$ L, 8-multi-cell)

# High energy over a wide wavelength Newly developed optics opens up new

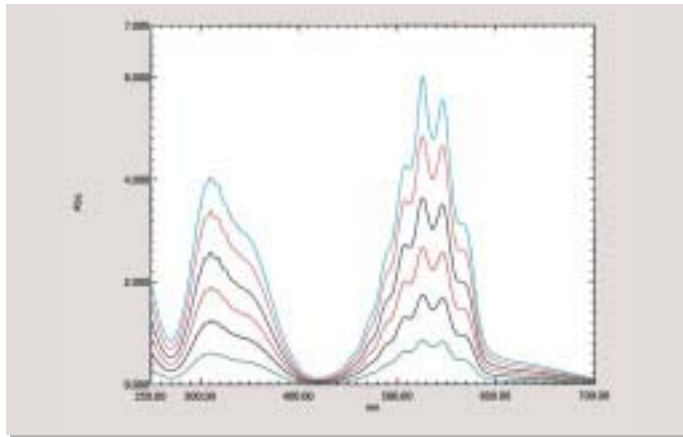

Potassium permanganate solution

## UV-2550 achieves world's lowest stray light

To accurately measure absorbance in the ultraviolet region. To analyze highly concentrated samples without the need for dilution. Satisfying these requirements absolutely requires a spectrophotometer with low stray light.

The double monochromator UV-2550 with its newly developed optical system achieves an unsurpassed 0.0003% (220nm, NaI) ultra low stray light. With a single monochromator system, linearity of absorbance at high sample concentration is lost due to stray light, while with this system, highly absorbing peaks are accurately measured.

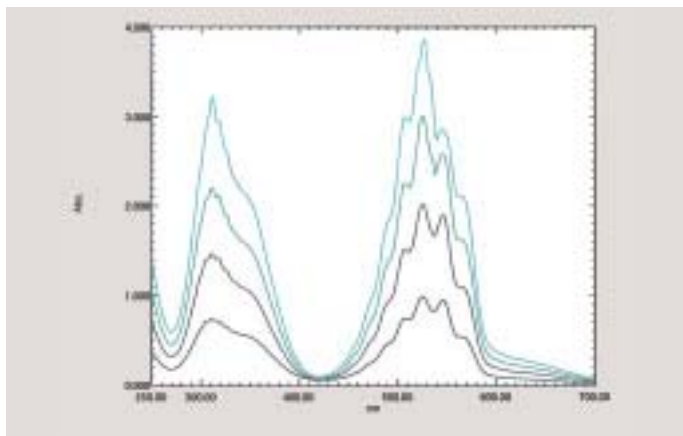

Analysis with single monochromator spectrophotometer

This shows analysis of the same sample using an existing single monochromator instrument. To accurately measure absorbances higher than this requires a double monochromator spectrophotometer providing lower stray light.

## Newly designed DDM optical system

The low stray light and high energy achieved by the UV-2550 is due to the newly developed DDM (double blazed grating, double monochromator) optical system.

### Blazing

To increase refraction efficiency of a grating with respect to specific wavelengths, the lattice groove faces are produced in a saw tooth configuration (blazing). By determining the appropriate groove face configuration to provide a mirror relationship between the incidental light on the grating and the refracted rays at a specific wavelength, a large portion of incidental energy at that wavelength can be concentrated.

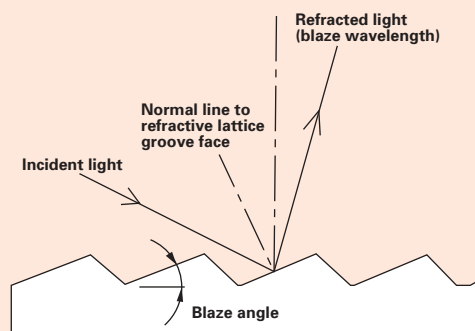

Blazed Grating

This type of grating is referred to as a blazed grating, and the wavelength at which the refractive efficiency is maximized is referred to as the blaze wavelength.

Only one wavelength can be set as the blaze wavelength based on the configuration of the grating grooves. Thus, while a blazed grating provides this excellent benefit at a specific wavelength, at other wavelengths there is an unavoidable decrease in energy. This disadvantage is addressed by adopting a monochromator comprised of two gratings, thereby preventing a large loss of light.

# range - efficiency and low stray light spectrophotometer applications

## High energy over wide wavelength range

Prior to the advent of "low stray light" double monochromator type spectrophotometers, adequate sensitivity could not be obtained over a wide wavelength range. The UV-2550 resolves this problem with its newly designed DDM optical system. While featuring low stray light, excellent energy characteristics are provided over an extremely wide wavelength range, from ultraviolet to visible, and to near infrared.

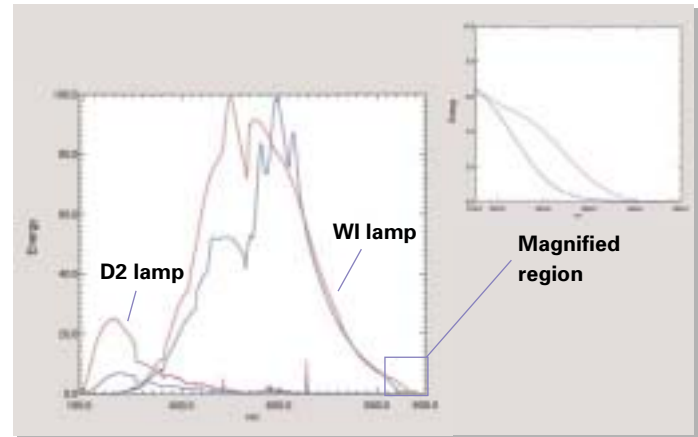

Energy curve — UV-2550 — Existing instruments

## DDM widens analysis range

The UV-2550 wavelength scanning range widens to 1100nm in the near infrared region.

With the high energy achieved by low stray light up into the near infrared region, accurate measurement is now possible at long wavelengths above 900nm.

This is ideal for analysis of semiconductors and optical parts and materials such as YAG lasers (about 1064nm), etc.

(This requires replacement of the detector with a near infrared sensitivity photomultiplier. This exchange enables widening of the wavelength range to 400 ~ 1100nm or to 190~1010nm. However, the optical specifications of the standard optical bench will not be satisfied in the modified configuration.)

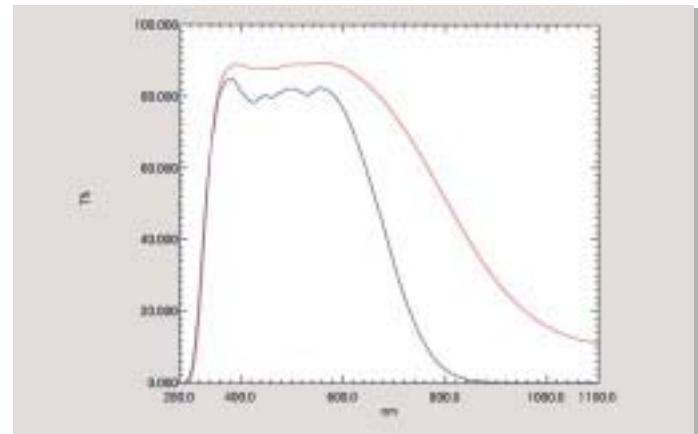

Transmittance spectrum of infrared absorption filter

## Double Blazed Grating Application

(Patent Pending)

The DDM optical system uses a holographic grating incorporating two different blaze angles to accommodate two wavelength regions, infrared and visible. Wavelength scanning is performed by rotating the grating eccentrically, changing the area to be used on the grating according to the wavelength.

This design enables appropriate blaze effectiveness and high refractive efficiency regardless of the wavelength region.

In this way, the DDM optical system eliminates the drawback of the existing simple blazed grating, providing low light and high measurement energy in this new type monochromator.

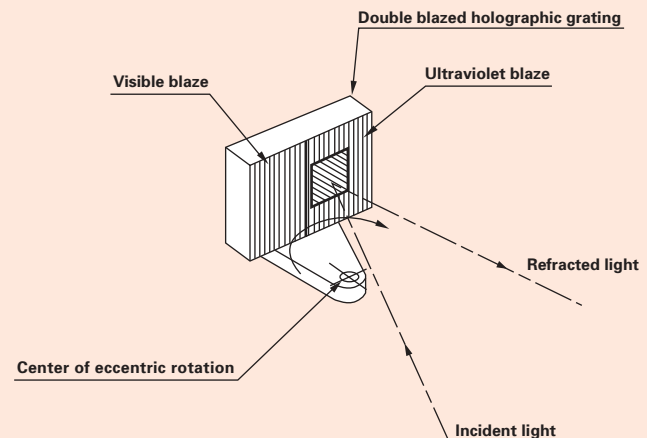

DDM Optical System

# All-in-one Software UVProbe

The UV-2450 and UV-2550 are controlled by a new generation of software, UVProbe. UVProbe includes all you need for spectrum, kinetics and photometric (quantitation) analyses. From basic measurement to sophisticated research analysis, UVProbe does it all.

## Features

- Compatible with Windows NT for stable operation
- Real QA/QC functionality achieved for the first time in UV software
- GLP/GMP support functions for perfect validation
- Robust report generator to satisfy every need
- Enhanced Help at your fingertips

## Report Generator

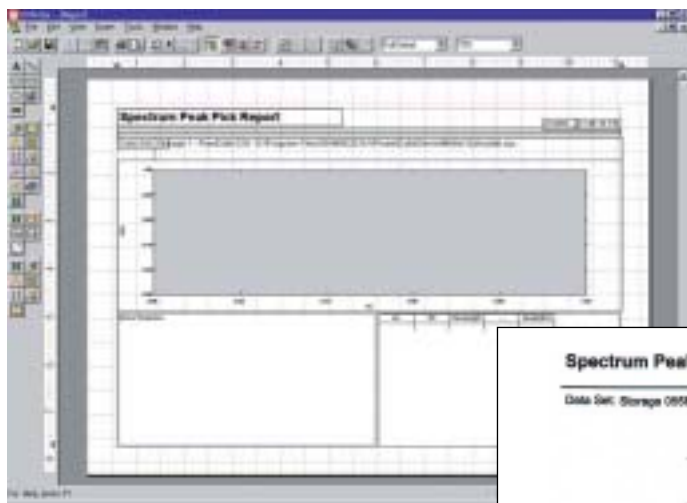

The report generator gives you the freedom to arrange graphs, tables, etc. to suit your needs. You can now specify the thickness and color of graph lines, as well as font size. Pasting labels on graphs and editing text is easy as can be, allowing you to effectively print comments along with the analysis results.

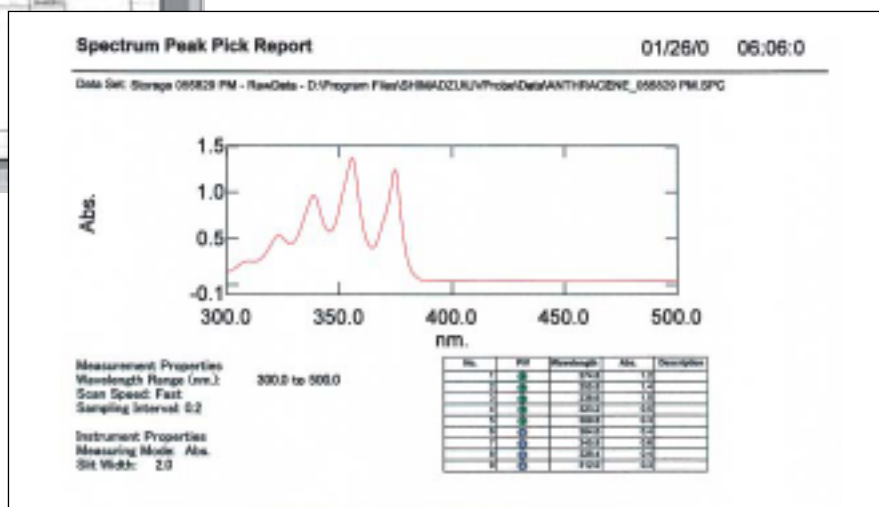

## Spectrum

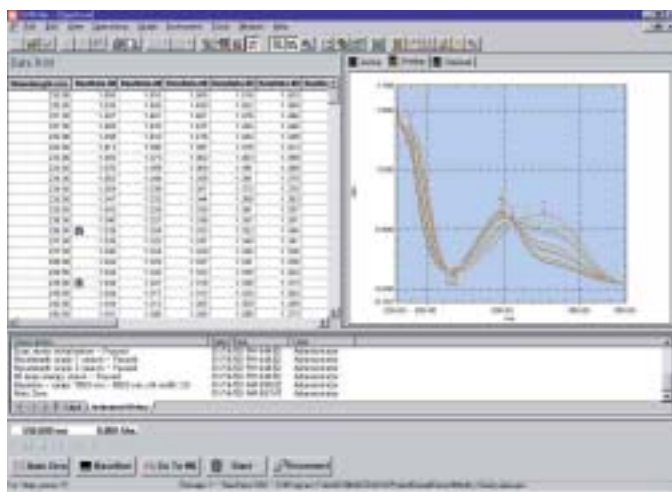

In the spectrum module, a specified wavelength range is scanned, and the photometric value is recorded for each sampling interval. Continuous spectrum measurement is possible using a multicell positioner. Various types of measurements are possible, such as repeat measurement to observe changes of the sample over time.

Functions :

Saving and recalling of measurement parameters (measurement method)

Data printout, peak detection, point pick, area calculation and other data processing functions

Data calculations like constants operations and blank correction, absorbance/transmittance conversion, integration and various other types of data conversion functions

## Kinetics



In the Kinetics module, changes in photometric values are measured as a function of time (Time Course measurement) at a fixed wavelength. Those data can then be used in kinetic value calculations, an ideal tool in life science applications.

Functions :

Single or double wavelength time course measurement is possible using difference or ratio, and using a multicell positioner, multiple samples can be measured simultaneously for changes over time.

Data printout, peak detection, point pick, area calculation and other data processing functions

Data calculations like constants operations and blank correction, absorbance/transmittance conversion, integration and various other types data conversion functions

Michaelis-Menten calculations, including Hill and Inhibitor constant calculations, and custom graph layout are possible

## Photometric

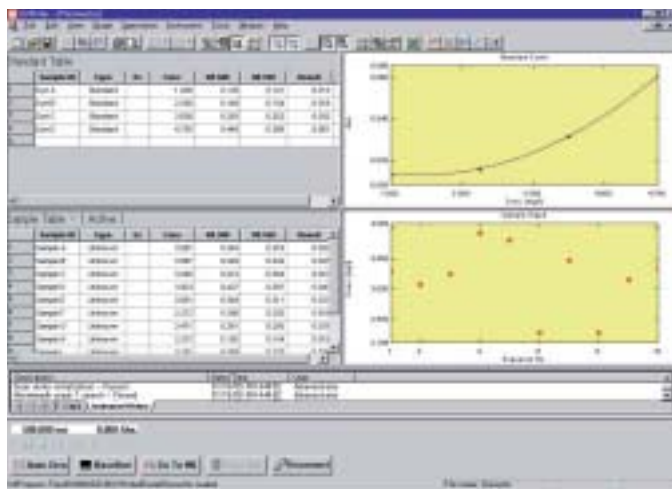

The Photometric module allows measurement of photometric values (photometric measurement) using multiple wavelengths. Various calibration curve methods are available (multi-point, single point and K factor calibration curves) for quantitation.

Functions :

Standards and sample tables can be created using either manual entry or the results of measurement.

Custom calculation equations using measurement values can be created, and the results can be displayed simultaneously in the same table along with the photometric values. Using this function eliminates the need for special software to perform DNA/protein quantitation.

Custom evaluation equations can be created to determine pass/fail of measurement results, and these indications can be displayed in the same table. QA/QC functions which up to now have required separate spreadsheet software are now included in UVProbe.

# UVProbe Functions

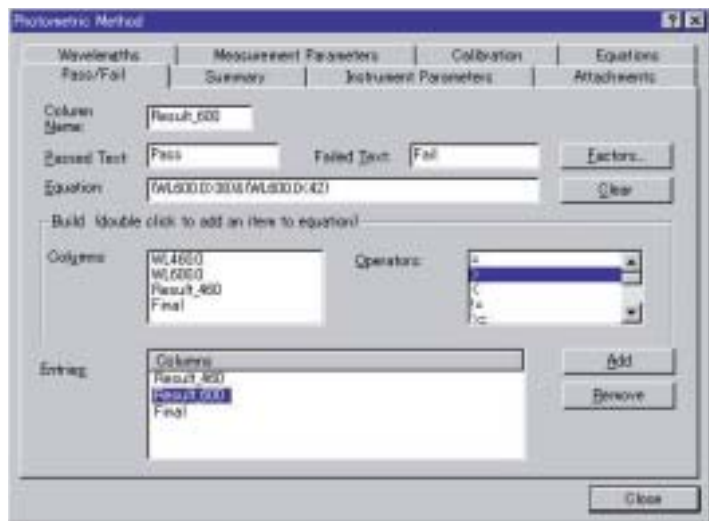

## Calculation Equations, QA/QC Functions

UVProbe allows custom definition of equations for evaluating measurement results. DNA and protein quantitation, which up to now was only available in special software or separate spreadsheet software, can now be performed in UVProbe. Also, UVProbe allows customization of equations for evaluating photometric values and calculated results. Evaluation results of unknowns which are measured can also be indicated as Pass/Fail, etc. in the table. Even complicated tests using multiple wavelengths can be evaluated.

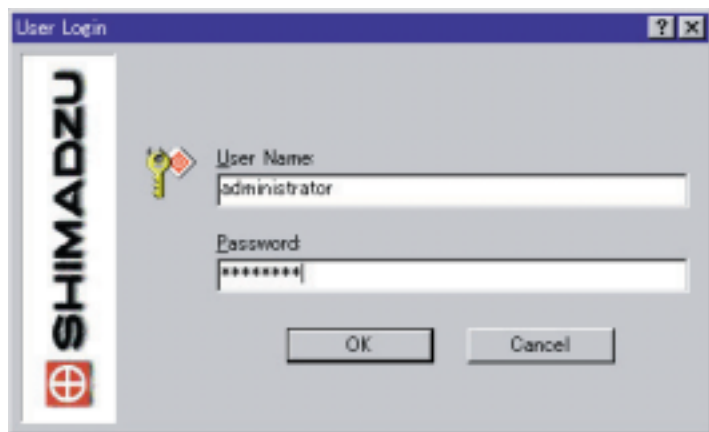

## GLP/GMP Support

UVProbe is GLP/GMP compliant

- 1 Security functions  
Each user is limited to the use of specific functions, and all data and measurement methods are protected.
- 2 Instrument audit trail  
Any effects on measurement data, including processing, are recorded in the instrument history log.
- 3 Data history log  
With the history log function, all processed data is stored along with the detail of the exact operation performed, and is saved alongside the original data for easy retrieval and tracking.

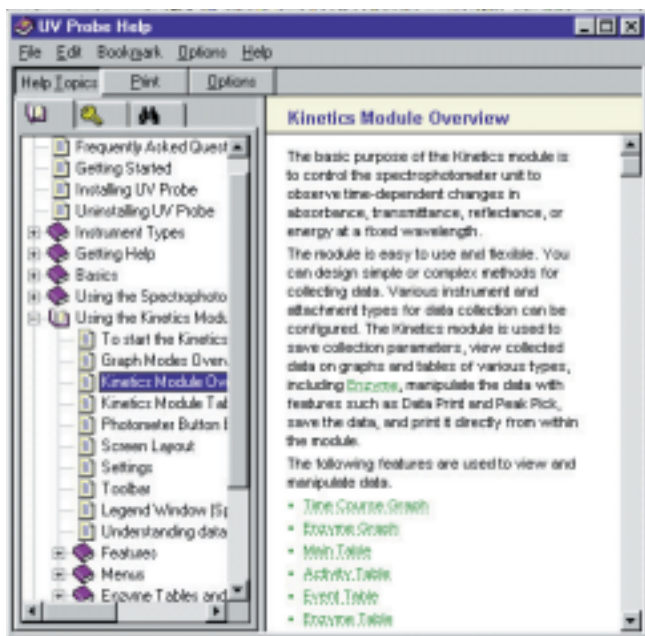

## On-line Help

Detailed explanations are available in easy-to-use Help screens to guide the user during software usage. Even item-by-item descriptions of displayed dialog boxes appear at the click of the mouse in pop-up boxes, enabling the user to verify specific operations.

# UVProbe Software Specifications

<b>Operating System</b>	Windows NT 4.0
<b>Instruments</b>	UV-1601 Series, UV-2401/2501 Series
<b>Data Acquisition Modes</b>	Spectrum, Kinetics and Photometric
<b>General</b>	Multitasking (Possible to execute data processing while measurement is being executed.) Customizable measurement screen layout (wavelengths, data display font and font size, colors, displayed number of rows) GLP/GMP compliant (security, history) Real time concentration display
<b>Spectrum Mode</b>	Comparison of multiple spectra/relative processing* <sup>2</sup> Save all processed data with original data set including a history of all manipulations Spectrum enlargement/shrinking, auto scale and Undo/Redo of these operations Annotation on spectrum screen
<b>Data Processing in Spectrum Mode</b>	Normalization, Point Pick, peak/valley detection, area calculation Transformations: 1 <sup>st</sup> - 4 <sup>th</sup> derivatives, smoothing, reciprocal, square root, natural log, logarithm power, Abs. to %T conversion, and exponential, Kubelka-Munk conversion Ensemble averaging, interpolation, data set and constants arithmetic (between spectra, between spectra and constants)
<b>Photometric (Quantitation) Mode</b>	Single wavelength, multi wavelength (includes 1, 2 or 3 wavelengths), spectrum quantitation (peak, maximum, minimum, area, etc. for specified wavelength ranges) Multi-point, single point, K-factor calibration curves (1 <sup>st</sup> , 2 <sup>nd</sup> , 3 <sup>rd</sup> order function fits, pass-through-zero specification) Photometric processing with user-defined functions (+, -, ×, ÷, Log, Exp, etc. functions, including factors) Weight correction, dilution factor correction, and other corrections using factors Averaging of repeat measurement data Simultaneous display of standard table, unknown table and calibration curves Display of Pass/Fail indications
<b>Kinetics (Time Course) Mode</b>	Comparison/relative data processing of multiple time course data* <sup>2</sup> Single or double wavelength measurement (difference or ratio) Simultaneous display of time course data, enzyme table and graphs Enzyme kinetics calculation (for single or multicell) Michaelis-Menten calculations and graph creation (Michaelis-Menten, Lineweaver-Burk, Hanes, Woolf, Eadie-Hofstee), Dixon plot, Hill plot Unitary management of sample information including original data, sample weight and dilution factors, etc. Event recording such as addition of reagents during measurement Time course spectrum data processing (same as in spectrum data processing)
<b>Report Generator</b>	Preview and print functions for customized formats Layout and editing of templates Quick printing using report templates Multi-page printout support Insert date, time, text, and drawing objects including lines, circles and rectangles Insert spectrum and quantitation data, method and history Headers and footers easily inserted Specify graph line thickness (as in all modules), font style and size

## Standard Contents

No.	Description	Quantity
1	Spectrophotometer main unit	1
2	Standard accessories Power cable Fuse Ground adapter	1
3	Software CD-ROM Transmission cable (IBM PC)	1
4	Instruction manual (Installation, Maintenance) Instruction manual (Operation) Quick Reference	1 1 1

### Notes

- 1 PC, monitor and printer are not included.
- 2 Depends on PC environment (memory, etc.) As a guideline, from 20 ~ 30 spectrum data sets. Required and recommended PC configuration for running UVProbe is as follows:  
IBM PC or 100% compatible PC with Pentium (200MHz) or better processor. (Pentium 300MHz) recommended  
64MB RAM, 128MB recommended  
50MB available hard disk capacity  
SVGA video monitor, 800 × 600 dot screen resolution (1024 × 768 recommended)  
Parallel and serial ports  
Graphic printer, or plotter (recommended for printing data)  
Mouse or similar pointing device  
CD-ROM drive

Even with the above configuration, UVProbe operating performance cannot be guaranteed, depending on Windows settings, hardware state, etc.  
Use Shimadzu recommended equipment, if possible.

# Application (Life Science and Environment)

## Life Science

Measurement of even minute biological samples is no problem. The high energy optics concentrate the light onto the samples for measurements using capillary cells (3 $\mu$ L) or the super micro black cell (50 $\mu$ L).

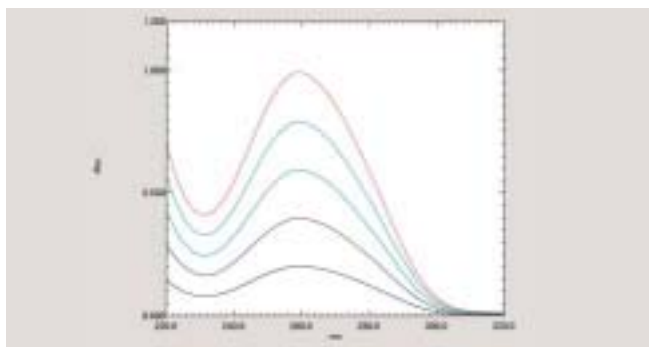

The DNA solution shown here was measured in a black walled super micro cell. Even measuring an extremely minute 50 $\mu$ L sample at below the 300nm UV region, low noise data was obtained up to a high concentration.

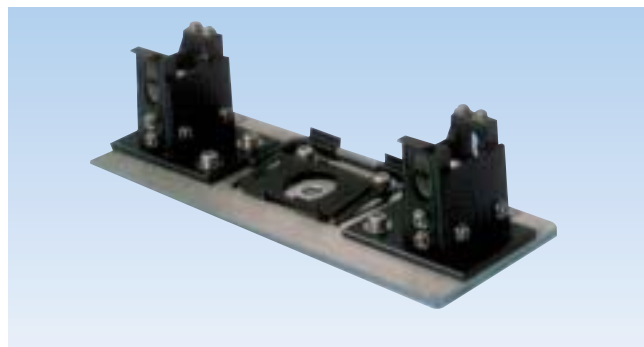

## Environmental Analysis

Total nitrogen content in waste water is regulated by law. To measure this total nitrogen, a specified reagent is added to the sample and heated to 120 $^{\circ}$ C, nitrogen oxide is changed to the nitric acid ion to break down the organic material. The

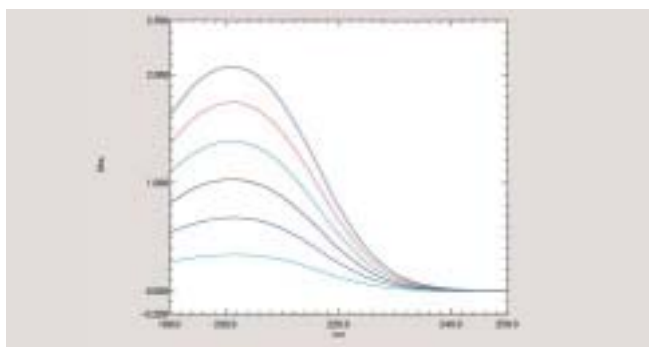

absorbance of the nitric acid ion in this solution is measured at 220nm, and quantitation is performed. In the quantitation measurement mode, the order of the calibration curve may be changed and poor data may be eliminated.

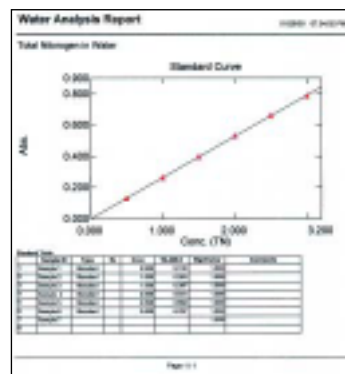

## Textile Analysis

Textile products including children's clothing and sleepwear are subject to residual formaldehyde regulations. In the JIS measurement method, formaldehyde is reacted with acetyl acetone, and the resultant peak is measured at 415nm.

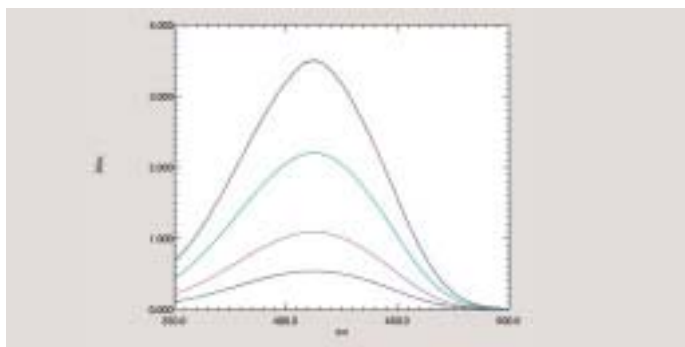

# Backed up by a variety of accessories.

## Large Sample Compartment

In cases where the sample does not fit in the standard sample compartment (glass plate, plastic products, etc.), there is no need to cut the sample. The multipurpose large sample compartment (MPC-2200) enables you to analyze these samples intact. Shown

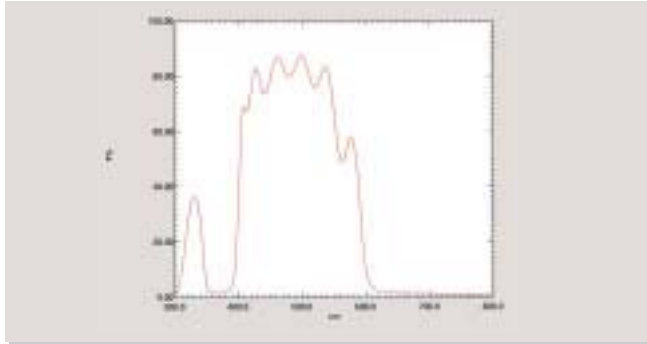

Transmittance (S Polarized Light)

here are transmittance and reflectance data from measurement of an optical disk beam splitter, using a 45° absolute specular reflectance attachment (ASR-3145) and the LPLR-1 Large Polarizer Assembly.

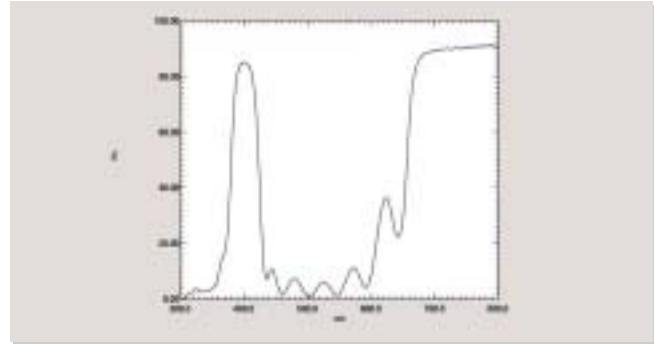

Reflectance (S Polarized Light)

## Integrating Sphere Measurement

One method of measuring water contamination is by analysis of the turbidity. To perform high sensitivity turbidity analysis, measurement is performed using an integrating sphere attachment. The ISR-2200 Integrating Sphere Attachment allows detection of a very acceptable 0.1 degree of turbidity.

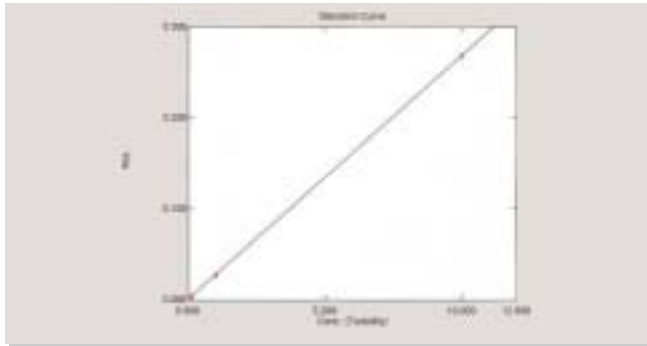

Using UVProbe to perform repeat photometric measurement, the average of values and standard deviation from measurement of multiple samples can be calculated automatically. Also, because the values in the table can be saved in text format, further analysis using spreadsheet software is possible.

Wavelength (nm)	Peak	Area	Height	Width	Resolution	Comments
1	365.0	1.0000	0.0000	0.0000	0.0000	
2	365.0	1.0000	0.0000	0.0000	0.0000	
3	365.0	1.0000	0.0000	0.0000	0.0000	
4	365.0	1.0000	0.0000	0.0000	0.0000	
5	365.0	1.0000	0.0000	0.0000	0.0000	
6	365.0	1.0000	0.0000	0.0000	0.0000	
7	365.0	1.0000	0.0000	0.0000	0.0000	
8	365.0	1.0000	0.0000	0.0000	0.0000	
9	365.0	1.0000	0.0000	0.0000	0.0000	
10	365.0	1.0000	0.0000	0.0000	0.0000	
11	365.0	1.0000	0.0000	0.0000	0.0000	
12	365.0	1.0000	0.0000	0.0000	0.0000	
13	365.0	1.0000	0.0000	0.0000	0.0000	
14	365.0	1.0000	0.0000	0.0000	0.0000	
15	365.0	1.0000	0.0000	0.0000	0.0000	
16	365.0	1.0000	0.0000	0.0000	0.0000	
17	365.0	1.0000	0.0000	0.0000	0.0000	
18	365.0	1.0000	0.0000	0.0000	0.0000	
19	365.0	1.0000	0.0000	0.0000	0.0000	
20	365.0	1.0000	0.0000	0.0000	0.0000	
21	365.0	1.0000	0.0000	0.0000	0.0000	
22	365.0	1.0000	0.0000	0.0000	0.0000	
23	365.0	1.0000	0.0000	0.0000	0.0000	
24	365.0	1.0000	0.0000	0.0000	0.0000	
25	365.0	1.0000	0.0000	0.0000	0.0000	
26	365.0	1.0000	0.0000	0.0000	0.0000	
27	365.0	1.0000	0.0000	0.0000	0.0000	
28	365.0	1.0000	0.0000	0.0000	0.0000	
29	365.0	1.0000	0.0000	0.0000	0.0000	
30	365.0	1.0000	0.0000	0.0000	0.0000	
31	365.0	1.0000	0.0000	0.0000	0.0000	
32	365.0	1.0000	0.0000	0.0000	0.0000	
33	365.0	1.0000	0.0000	0.0000	0.0000	
34	365.0	1.0000	0.0000	0.0000	0.0000	
35	365.0	1.0000	0.0000	0.0000	0.0000	
36	365.0	1.0000	0.0000	0.0000	0.0000	
37	365.0	1.0000	0.0000	0.0000	0.0000	
38	365.0	1.0000	0.0000	0.0000	0.0000	
39	365.0	1.0000	0.0000	0.0000	0.0000	
40	365.0	1.0000	0.0000	0.0000	0.0000	
41	365.0	1.0000	0.0000	0.0000	0.0000	
42	365.0	1.0000	0.0000	0.0000	0.0000	
43	365.0	1.0000	0.0000	0.0000	0.0000	
44	365.0	1.0000	0.0000	0.0000	0.0000	
45	365.0	1.0000	0.0000	0.0000	0.0000	
46	365.0	1.0000	0.0000	0.0000	0.0000	
47	365.0	1.0000	0.0000	0.0000	0.0000	
48	365.0	1.0000	0.0000	0.0000	0.0000	
49	365.0	1.0000	0.0000	0.0000	0.0000	
50	365.0	1.0000	0.0000	0.0000	0.0000	

## Light Source Measurement

Light emitting bodies, such as LEDs and semiconductor lasers, can also be measured using a fiber optic attachment or by placement in the light source compartment. Shown here is

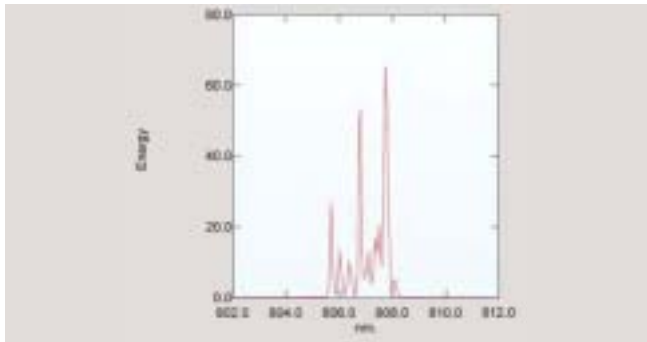

measurement of light emission from a semiconductor laser. It is clear that oscillation is occurs in multi mode.

# Spectrophotometer Specifications

Item	Description
Setting wavelength range	190 ~ 1100nm
Measurement wavelength range	190 ~ 900nm (up to 1100nm with special detector)
Wavelength accuracy	±0.3nm with auto wavelength correction included
Wavelength repeatability	±0.1nm
Wavelength scanning speed	Wavelength slew rate: about 3200nm/min Wavelength scan rate: about 900 ~ 160nm/min Monitor scan rate: about 2500nm/min
Wavelength setting	At 1nm units for scan start and scan end wavelengths, and 0.1nm units for other wavelengths
Lamp interchange wavelength	Auto switching synchronized with wavelength, switching range selectable between 282 ~ 393nm (0.1nm units)
Spectral bandwidth	6-step switching among 0.1/0.2/0.5/1/2/5nm
Response	Optimum response speed automatically set depending on bandwidth, minimum 0.1sec
Resolution	0.1nm
Stray light	UV-2450                      UV-2550
	Less than 0.015%              Less than 0.0003% (220nm, NaI 10g/L solution) Less than 0.015%              Less than 0.0003% (340nm, UV-39 filter)
Photometric system	Double-beam, direct ratio system with dynode feedback
Photometric modes	Absorbance (Abs.), transmittance (%), reflectance (%), energy (E)
Photometric range	Absorbance: -4 ~ 5 Abs Transmittance, reflectance: 0.0 ~ 999.9%
Recording range	Absorbance: -9.999 ~ 9.999 Abs Transmittance, reflectance: -999.9 ~ 999.9%
Photometric accuracy	±0.002 Abs (0 ~ 0.5 Abs) ±0.004 Abs (0.5 ~ 1.0 Abs) ±0.3%T (0 ~ 100% T) } Tested with NIST 930D standard filter

Item	Description
Photometric repeatability	±0.001 Abs (0 ~ 0.5 Abs)
	±0.002 Abs (0.5 ~ 1.0 Abs) ±0.1%T
Baseline flatness	±0.001 Abs (excluding noise, using 2nm slit, and slow wavelength scanning speed)
Baseline correction	Auto correction using PC (Stored baseline is automatically loaded when power is switched on, re-correction is possible)
Drift	0.0004Abs/h (after power is on for 2 hours)
Temperature and humidity requirements	15 ~ 35°C, 45 ~ 80% (no condensation, less than 70% above 30°C)
Light source	50W halogen lamp (2,000 hours life), deuterium lamp (socket type), light source auto position adjustment built in
Monochromator	UV-2450
	Single monochromator, high-performance blazed holographic grating in aberration-corrected Czerny-Turner mounting UV-2550 Grating/Grating type double monochromator, Pre-monochromator: double-blazed holographic grating Main monochromator: high-performance blazed holographic grating in aberration-corrected Czerny-Turner mounting
Detector	Photomultiplier R-928
Sample compartment	Internal dimensions: 150W × 260D × 120H (mm) Distance between light beams: 100mm Maximum light path length of cell: 100 mm
Power requirements	AC100, 120, 220, 240 V, switch selectable 50/60Hz; 250 VA
Dimensions	570W × 660D × 275H (mm)
Weight	About 36 kg

(PC and printer are not included.)

If the detector has been replaced with a near infrared sensitive photomultiplier, the standard optical specifications of the above instrument will not be satisfied.

## Installation Area Plan (UV-2450/2550)

Additional adjacent space is also required for the PC and printer.

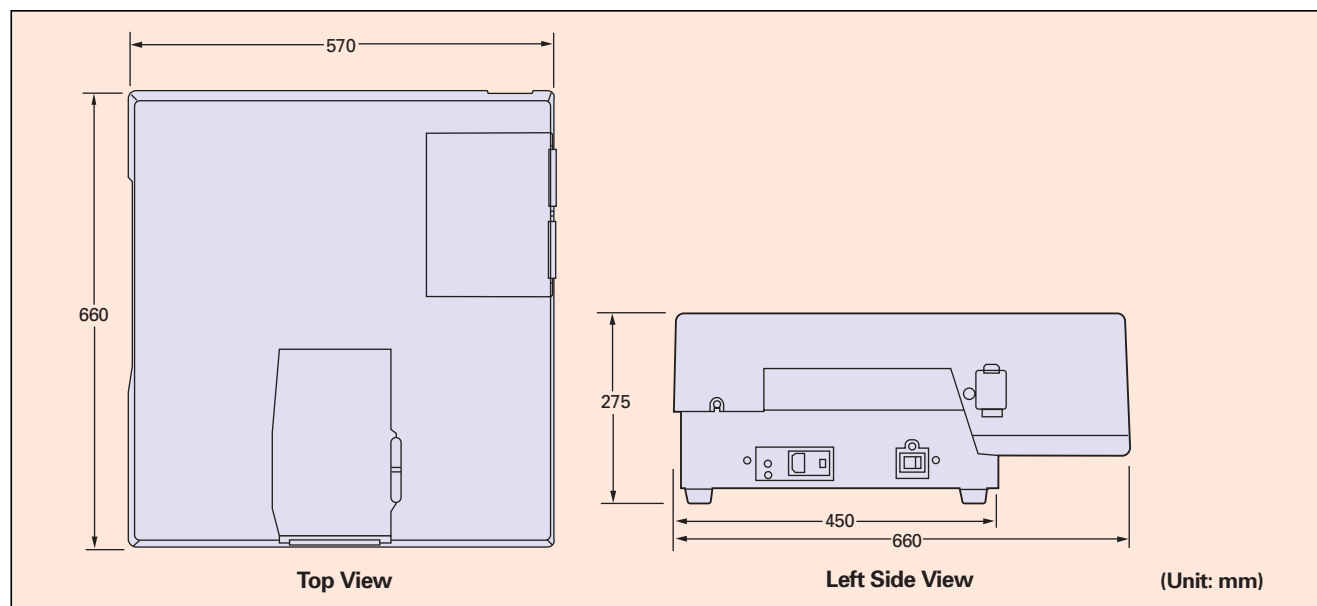

# Accessories

## TCC-240A Thermoelectrically Temperature Controlled Cell Holder

(Cat. No. 204-05557-\*\*)

Uses Peltier effect for controlling the temperatures of the sample and reference sample. No thermostatic bath or cooling water is required, so the operation is quite simple and easy.

Number of cells: One each on the sample and reference sides.

Temperature control range: 7 to 60°C

Temperature display accuracy (difference from the true value):  $\pm 0.5^\circ\text{C}$

Temperature control precision (variation of temperature):  $\pm 0.1^\circ\text{C}$

Note: Sample cells (Cat. No. 200-34442) are not included in the standard contents.



## CPS-240A Cell Positioner, Thermoelectrically Temperature Controlled

(Cat. No. 204-05837-\*\*)

This attachment permits measurement of up to six sample cells under constant temperature conditions. Combination of this attachment and the Kinetics mode provides measurement of temperature sensitive enzyme kinetics of one to six samples.

Number of cells: 6 on the sample side (temperature controlled)

1 on the reference side (temperature not controlled)

Temperature control range: 16 to 60°C

Temperature display accuracy (difference from the true value):  $\pm 0.5^\circ\text{C}$

Temperature control precision (variation of temperature):  $\pm 0.1^\circ\text{C}$

Ambient temperature: 15 to 35°C

Note: Sample cells (Cat. No. 200-34442) are not included in the standard contents.



## Sipper Unit 160L (Standard Sipper)

(Cat. No. 204-08270-01)

## Sipper Unit 160T (Triple Pass Sipper)

(Cat. No. 204-08270-02)

## Sipper Unit 160C (Constant Temperature Sipper)

(Cat. No. 204-08270-03)

## Sipper Unit 160U (Supermicro Sipper)

(Cat. No. 204-08270-04)

The four sippers listed above are available, depending on the flow cell shape. A peristaltic pump driven by a stepping motor ensures reliable and smooth aspiration of sample solution. (Direct drive is possible from the UV-2450/2550, so no interface is required.)

Note: The use of a Teflon Valve Unit (Cat. No. 204-06599-01) and the SWA-2 Sample Waste Unit (Cat. No. 204-29230) are recommended when strong acids, strong alkalis, or organic solvents are to be measured.

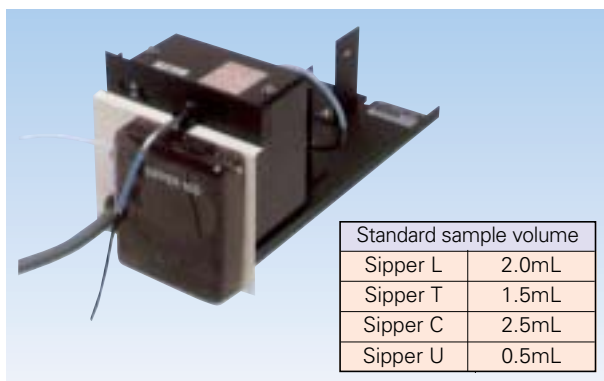

## ASC-5 Auto Sample Changer

(Cat. No. 204-09100-\*\*)

Combine with a Sipper 160 to build an automated multisample spectrophotometry system.

The aspirating nozzle is programmed to move in the X, Y, and Z (vertical) directions.

Up to 8 sets of operational parameters, including the size of racks and the number of test tubes, may be memorized in the battery back-up protected files.

Up to 100 test tubes may be set together on the rack.

Note: A commercially available test tube stand, with a footprint smaller than 220 x 220mm, is applicable.



# Accessories

## Multicell Sample Compartment

(Cat. No. 206-69160)

Holds up to six 10 mm square cells. No temperature control capability.

Number of cells: 6 on the sample side  
1 on the reference side

\* Cells are not included in the standard contents.

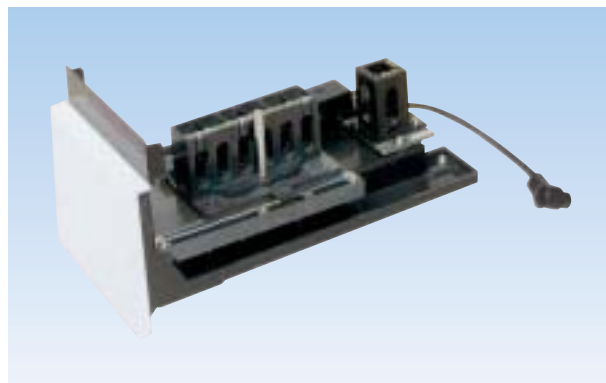

## 3 $\mu$ L Capillary Cell Set for Ultramicro Volume Measurement

(Cat. No. 206-69746)

Recommended for small and precious samples, such as in biological application. The minimum sample volume required is 3 $\mu$ L, when the tube closure is used. (theoretical value)

Solution sample is aspirated into the capillary cell and the cell is subjected to measurement.

The holder is the same size as a 10 mm square cell and can be mounted to the standard cell holder.

Supplied with 100 capillaries (made of quartz) and a tube closure.



## Supermicro Cell Holder

(Cat. No. 206-14334)

Holds supermicro cells for measurement of extremely small samples. The cell height is adjustable and the sample volume required is variable from 50 $\mu$ L to 200 $\mu$ L, depending on the type of black cell used.

Applicable cell: ⑦ and ⑧ in the list of cells on the back cover. (Cells are not included in the standard contents.)

Mask: Choice of 1.5<sup>W</sup> × 1<sup>H</sup> mm and 1.5<sup>W</sup> × 3<sup>H</sup> mm

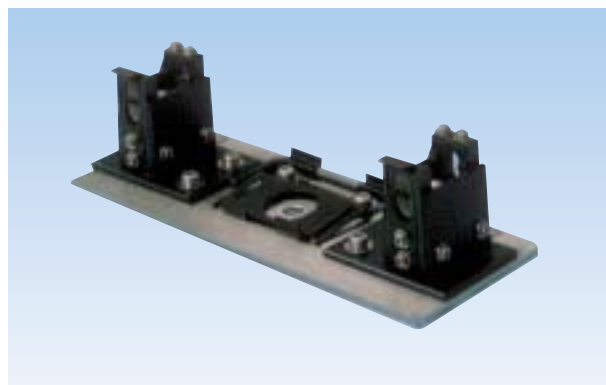

## Specular Reflectance Measurement Attachment (5° incident angle)

(Cat. No. 206-14046)

The technique of specular reflectance measurement is often utilized for evaluation of semiconductors and optical materials relative to a reference reflecting surface. The 5° incident angle minimizes the influence of polarized light. Thus, no polarizer is required in measurement ••• the operation is quite simple.

Samples as large as 100<sup>W</sup> × 160<sup>D</sup> × 15<sup>T</sup> mm can be readily measured, the minimum size is 7 mm in diameter.

Sample placement is quite easy ••• just set it on the holder with the measuring face down.

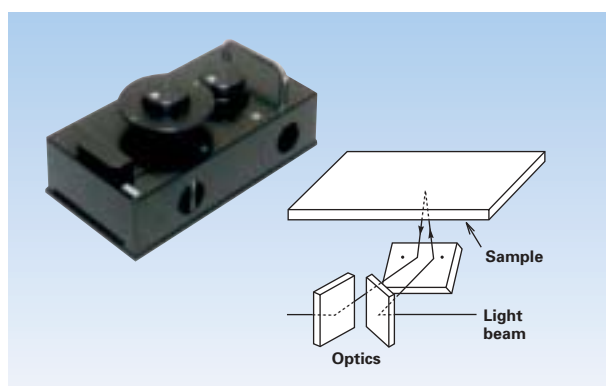

# Accessories

## 8/16 Series Micro Multi-cell Holder MMC-1600

(Cat. No. 206-53945-91)

## 8/16 Series Constant Temperature Micro Multi-cell Holder MMC-1600C

(Cat. No. 206-53900-91)

This cell holder holds one micro multi-cell, either 8 or 16 cell, for micro volume measurement.

Two types of micro multi-cell holders are available, the standard type (MMC-1600) and the constant temperature water circulation type (MMC-1600C).

### Micro Multi-cells

Model	Cat. No.
8 Series Micro Multi-cell; optical path length 10mm, cell volume 100 $\mu$ L	208-92089
16 Series Micro Multi-cell; optical path length 10mm, cell volume 100 $\mu$ L	208-92088
8 Series Micro Multi-cell; optical path length 5mm, cell volume 50 $\mu$ L	208-92086
16 Series Micro Multi-cell; optical path length 5mm, cell volume 50 $\mu$ L	208-92085

There are two types of micro multi-cells available in both the 8 Series and the 16 Series models, a 50 $\mu$ L type and a 100 $\mu$ L type. The cell intervals of the 8 Series Micro Multi-cell are applicable for use with 8 12 well microplates and 8 channel pipettes. Microplate samples aspirated into multi channel pipettes can be injected directly into the cells for measurement.

Micro volume samples can be measured  
(minimum sample volume: 50 $\mu$ L or 100 $\mu$ L, respectively)  
Support for commercial microplates and micro pipettes.  
(with 8 Series micro cells)  
Up to 16 samples can be measured at a time (with 16 Series micro cell)



## Syringe Sipper N (Normal temperature type)

(Cat. No. 206-53800-93)

## Syringe Sipper CN (Constant temperature, water circulating type)

(Cat. No. 206-53800-94)

The sipper unit employs a syringe pump system. The liquid contact surfaces are composed of Teflon, glass, or quartz, imparting excellent chemical resistance and ease of maintenance, and allowing measurement of almost any sample type. Further, the extremely high repeatability of sipping volume (repeat precision:  $\pm 0.03$ mL) makes it ideal when performance validation is required.



Flow cell available separately. Choose from the recommended flow cells listed below.

Cell Type	Cat. No.	Optical Path Length	Dimensions of Aperture	Standard Required Sample Volume
Square (Ultra-micro)	208-92114	10mm	2mm	0.9mL
Square (Micro)	208-92113	10mm	3mm	1.0mL
Square (Semi-micro)	208-92005	10mm	H11 W3.5mm	5.0mL

The flow cell can be changed independently for excellent ease of maintenance.  
Excellent chemical resistance allows measurement of almost any sample.  
Excellent repeat sipping of fixed volumes.

# Accessories

## ISR-2200 Integrating Sphere Attachment (Cat. No. 206-61600)

With a wide UV-VIS wavelength range of 220nm to 850nm, this instrument can be used for reflectance measurement of diffuse samples, specular reflectance measurement and transmittance measurement of turbid samples.

By combining the 0°/8° incidence angle integrating sphere with the S/R exchange function of the spectrophotometer, diffuse and specular reflectance measurements are possible without the need for any special attachments.

The size of the light beam for reflectance measurement can be changed, enabling reflectance measurement of micro samples (minimum light beam dimensions about 2 × 3mm). Light beams for transmittance measurement can be concentrated to dimensions of 3 × 3mm.

Integrating sphere: inner diameter 60mm

Maximum size of reflectance sample: 70<sup>W</sup> × 70<sup>H</sup> × 20<sup>T</sup>mm (0° incidence side)

70<sup>W</sup> × 70<sup>H</sup> × 12<sup>T</sup>mm (8° incidence side)

The ISR-240A Integrating Sphere Attachment (Cat. No. 204-52454-01) is also available.

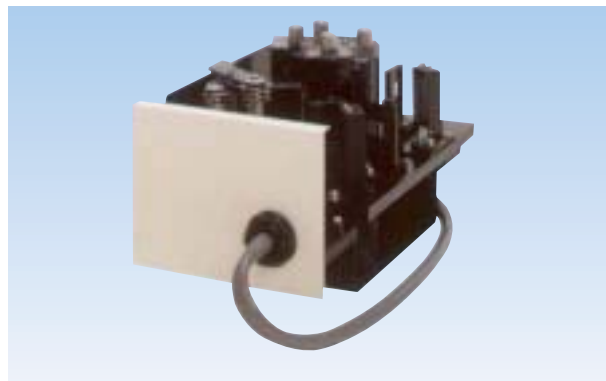

## MPC-2200 Multipurpose Sample Compartment (Cat. No. 206-62200)

This is a multipurpose sample compartment enabling both reflectance and transmittance measurement of samples having a wide variety of shapes. An integrating sphere is built in to permit accurate measurement of solid samples. The sample space around the integrating sphere is ample enough to allow measurement of very large samples.

### Applicable fields

Semiconductors: Transmittance /reflectance measurement of silicon wafers, etc.

Liquid crystals: LCD evaluation, TFT research

Thin film: Various vapor deposition films, film thickness measurement

Optical elements: Transmittance /reflectance measurement of various lenses, prisms

Glass materials: Window materials, (transmittance of infrared rays), laser rod measurement

Plastics: Transmittance /reflectance measurement of optical disks

### Features

- Wide sample space allowing measurement of even a 12-inch disk  
Maximum sample size: Transmittance: 305mm dia. × 50mm thick or 204mm dia. × 300mm thick  
Reflectance: 305mm dia. × 50mm thick
- With independent S beam / R beam switching, 0°/8° incidence angle reflectance measurement is possible without tilting the sample.
- With the integrating sphere shift function, the range of applications is widened further.
- Wide wavelength range with integrating sphere: 240 ~ 800nm
- Height-adjustable V stage is built in.

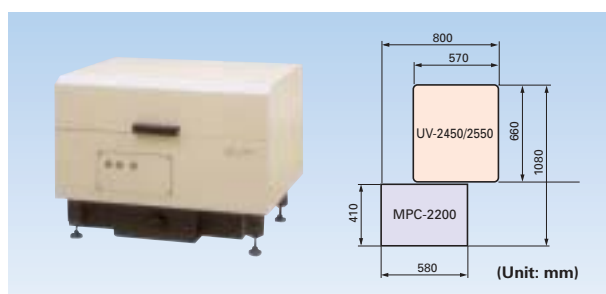

## ASR-3105 Absolute Reflectance Attachment, 5° (Cat. No. 206-16817)

## ASR-3112 Absolute Reflectance Attachment, 12° (Cat. No. 206-16100)

## ASR-3130 Absolute Reflectance Attachment, 30° (Cat. No. 206-15001)

## ASR-3145 Absolute Reflectance Attachment, 45° (Cat. No. 206-15002)

These accessories are intended for use with the MPC-2200 Sample Compartment, and require the BIS-3100 Sample Base Plate-Integrating Sphere Set (Cat. No. 206-17059). At larger angles of incidence (30°, 45°), a polarizer is also required.

Wavelength range: 300 ~ 800nm

Accuracy: with respect to 90% reflectance samples

Incidence angle 5°: ±1.5%

Incidence angle 12°: ±1.0%

Incidence angle 30°, 45°: ±2.5%

100% level sample setting: The sample measurement light path can be switched using the single touch V-N method.

Approximate sample size: 25 ~ 200mm dia., or 20 ~ 150mm square, up to 30mm thick

The BIS-3100 Sample Base Plate-Integrating Sphere Set (Cat. No. 206-17059) is required for mounting these absolute specular reflectance attachments.

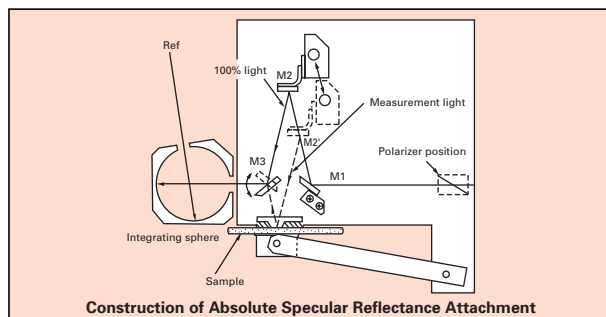

# Accessories

## NTT-2200P Constant-Temperature Water Circulator (Cat. No. 208-97263)

Circulates temperature controlled water to a constant-temperature cell holder.

- Temperature range: Ambient +5°C to +80°C
- Temperature control precision:  $\pm 0.05^\circ\text{C}$
- Max. pumping rate: 27/31 L/min, 9.5/13 m (50/60 Hz)
- External circulation nozzle: 10.5 mm OD (both outlet and return)
- Tank capacity: About 10 L (9 L during use)
- Safety feature: Detection of over-temperature of Upper or Lower limits, Detection of heater wire malfunction, Protection of heating too few circulating water, Detection of sensor malfunction, Independent over heat protection, Over current circuit protector
- Standard accessories: Lid with handles, Rubber hose (4m), Hose clamps (4pc.), Instruction manual
- Dimensions: 270W x 560H x 400D (mm)
- Power requirements: 100 VAC, 1250 VA, with 1.7 m power cord and grounded plug



## S-1700 Thermoelectric Single Cell Holder (Cat. No. 206-56000-91)

This cell holder permits setting of a temperature program to increase and decrease the sample cell temperature.

- The thermoelectric system allows prompt control of sample temperature between  $0^\circ\text{C}$  and  $110^\circ\text{C}$ .
- Temperature increase/decrease speed can be changed using 12 settings, which means the holder can be used in analysis of melting curves for nucleic acids, etc., that occur during quick as well as slow heating (or cooling).
- A stirrer also is provided to ensure uniform temperature distribution throughout the cell.
- A cooling water circulation is required for Peltier element cooling. And though tap water can be used, it is recommended that a commercially available constant-temperature water circulator be used, as the following conditions must be fulfilled to exact maximum performance from the S-1700.
  - Cooling water specification:  $20 \pm 2^\circ\text{C}$
  - Water flow: 4.8L / min or more
- Temperature is not controlled at the reference side.
- Cells are not supplied. Please use 10mm square tight-sealing cells (a Hellma product).

Type	Optical Path	Minimum Sample Volume Required
110-QS-10	10mm	3.5mL
115B-QS-10	10mm	400 $\mu\text{L}$

- Temperature accuracy in cell (when room temperature is  $25^\circ\text{C}$ )
  - Within  $\pm 0.25^\circ\text{C}$  (0 to  $25^\circ\text{C}$ )
  - Within  $\pm 1\%$  of set value (25 to  $75^\circ\text{C}$ )
  - Within  $\pm 2\%$  of set value (75 to  $110^\circ\text{C}$ )



## Tm Analysis Software (Cat. No. 206-57476-91)

- This software works with the S-1700 and accumulates temperature-versus-absorbance curve data at the PC to analyze the Tm (melting temperature) of nucleic acids such as DNA and RNA. The right figure is a typical setup for this software.
- RS-232C cables (Cat. No. 200-86408) are needed to connect the PC to the S-1700 and the spectrophotometer.

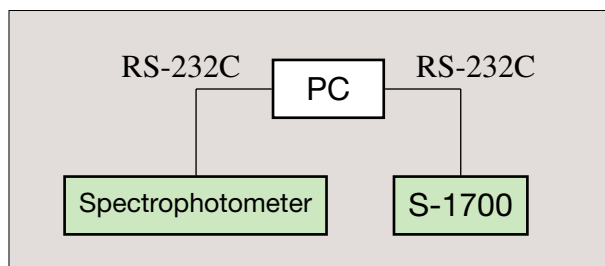

# Other Accessories

## ■ Basic Measurement

Part Name	Cat. No.	Remarks
Film holder	204-58909	For film transmittance measurement
Didymium filter	202-30242	For checking instrument operation
Holmium filter	202-30242-05	For checking instrument operation
Filter set	206-11343	Didymium filter and shutter block set
Four-cell sample compartment	204-00850-01	Manual switching

## ■ Short Optical Path Length Measurement

Part Name	Cat. No.	Remarks
Spacer for short optical path length cell	204-21473-03	For 1mm Inserted in cell holder
For 2mm	204-21473-01	Inserted in cell holder
For 5mm	204-21473-02	Inserted in cell holder

## ■ Long Optical Path Length Measurement

Part Name	Cat. No.	Remarks
Four-cell rectangular long pass absorption cell holder	204-27208	For 10, 20, 30, 50, 70, 100mm cells Four-cell sample compartment (204-00850-01) required
Reference side rectangular long pass absorption cell holder	204-28720	For 10, 20, 30, 50, 70, 100mm cells
Rectangular long pass cell holder	204-23118-01	For 10, 20, 30, 50, 70, 100mm cells
Cylindrical cell holder	204-06216-02	For 10, 20, 50, 100mm cylindrical cells

## ■ Micro Volume Measurement

Part Name	Cat. No.	Remarks
Cell holder with Micro cell mask	204-06896	For semi micro/ micro cell with light path width less than 4mm

## ■ Constant Temperature Measurement

Part Name	Cat. No.	Remarks
Constant temperature cell holder	202-30858-04	Constant temperature water circulating type
Constant temperature four-cell holder	204-27206-02	Constant temperature water circulating type Four-cell sample compartment (204-00850-01) required

## ■ Automatic Measurement

Part Name	Cat. No.	Remarks
SWA-2 Sample Waste Unit	204-29230	Sample aspiration, waste discharge vacuum pump
All Teflon Solenoid Valve Unit	204-06599-01	Enhances corrosion resistance of sipper unit
10mm micro flow cell	204-06222	Flow cell unit without aspirator
5mm micro flow cell	204-06222-01	Flow cell unit without aspirator
Front panel with holes	204-27588-03	Allows tubes of flow cell, etc., to be connected through instrument front panel.
Flow cell for liquid chromatography	206-12852	Optical path length: 10mm, Inner dia.: 1mm, Internal volume: 8μL
Sample pretreatment automation connection kit	206-80880-01	Connection kit for Autosampler 222XL, Flow Cell, with connection cables

## ■ Suspensions, Solid Sample Measurement

Part Name	Cat. No.	Remarks
ISR-240A Integrating Sphere Attachment	204-52454-01	Inner dia. 60mm Integrating Sphere
Opal Glass Accessory	202-30856	For suspension samples, wavelength range: 400~900nm
BIS-3100 Sample Base Plate-Integrating Sphere Set	206-17059	For mounting of absolute specular reflectance attachments (ASR-31xx)
LRLR-1 Large Polarizer Set	206-15694	Effective diameter: 20mm, wavelength range: 250~2500nm
PLR-1 Polarizer Type	206-13236-01	Effective diameter: 18mm, wavelength range: 400~800nm
PLR-2 Polarizer Type	206-13236-02	Effective diameter: 17mm, wavelength range: 260~700nm
PLR-3 Polarizer Type	206-13163	Effective diameter: 11mm, wavelength range: 260~2500nm
Polarizer Adapter Set	206-15693	Adapter for adjusting height of Polarizer Types

## ■ Gel Measurement

Part Name	Cat. No.	Remarks
GSC-3A Gel Scanner	204-51774-01	Applicable cell: 6 <sup>W</sup> × 77.5 <sup>L</sup> × 11 <sup>H</sup> mm Movement distance: 60mm

# Cells

Description	Optical path ( $\ell$ )	Type	Fused silica (S) Cell	Glass (G) Cell
Square cell	10mm	①	200-34442	200-34565
	20mm	⑥	200-34446	200-34446-01
	50mm	⑥	200-34944	200-34944-01
	100mm	⑥	200-34676	200-34676-01
Square cell with stopper	10mm	②	200-34444	200-34444-01
Semi-micro cell	10mm	③	200-66501	200-66501-01
Semi-micro black cell	10mm	③'	200-66551	—
Super micro black cell	10mm	⑦	200-66578-11	—
	5mm	⑦'	208-92116	—
Micro black cell	10mm	⑧	200-66578-12	—
Cylindrical cell	10mm	④	200-34448 (silica window)	200-34448-01 (glass window)
	20mm		200-34472 (silica window)	200-34472-01 (glass window)
	50mm		200-34473-01 (silica window)	200-34473-03 (glass window)
	100mm		200-34473-02 (silica window)	200-34473-04 (glass window)
Short path cell	1mm	⑤	200-34660-01	200-34662-01
	2mm		200-34655	200-34662-11
	5mm		200-34449	200-34449-01

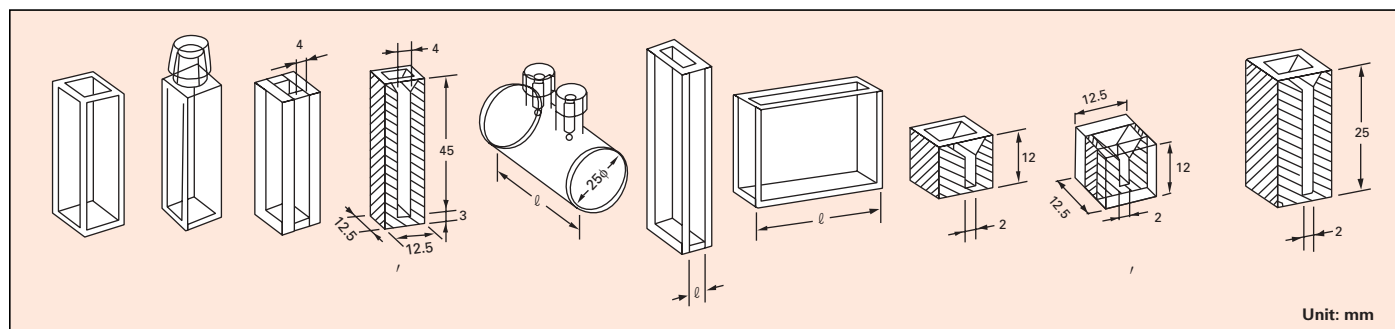

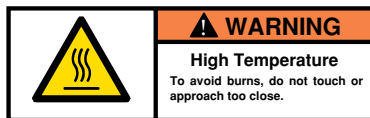
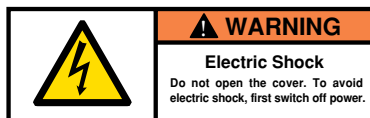

**SHIMADZU CORPORATION. International Marketing Division**

3. Kanda-Nishikicho 1-chome, Chiyoda-ku, Tokyo 101-8448, Japan Phone: 81(3)3219-5641 Fax: 81(3)3219-5710  
Cable Add.:SHIMADZU TOKYO

**SHIMADZU SCIENTIFIC INSTRUMENTS, INC.**

7102 Riverwood Drive, Columbia, Maryland 21046, U.S.A.  
Phone: 1(410)381-1227 Fax: 1(410)381-1222 Toll Free: 1(800)477-1227

**SHIMADZU DEUTSCHLAND GmbH**

Albert-Hahn-Strasse 6-10, D-47269 Duisburg, F.R. Germany Phone: 49(203)7687-0 Fax: 49(203)766625

**SHIMADZU (ASIA PACIFIC) PTE LTD.**

16 Science Park Drive #01-01 Singapore Science Park, Singapore 118227, Republic of Singapore  
Phone: 65-778 6280 Fax: 65-779 2935

**SHIMADZU SCIENTIFIC INSTRUMENTS (OCEANIA) PTY. LTD.**

Units F, 10-16 South Street Rydalmere N.S.W. 2116, Australia  
Phone: 61(2)9684-4200 Fax: 61(2)9684-4055

**SHIMADZU DO BRASIL COMERCIO LTDA.**

Rua Cenzo Sbrighi, 25, Agua Branca, Sao Paulo, CEP 05036-010, BRAZIL  
Phone: (55)11-3611-1688 Fax: (55)11-3611-2209

**SHIMADZU (HONG KONG) LIMITED**

Suite 1028 Ocean Center, Harbour City, Tsim Sha Tsui, Kowloon HONG KONG  
Phone: (852)2375-4979 Fax: (852)2199-7438

**Overseas Offices**

Istanbul, Beijing, Shanghai, Guangzhou, Shenyang, Chengdu, Moscow

**URL <http://www.shimadzu.com>**