

***THE SAFETY
STANDARD
IN FLASHPOINT
TESTING***



**GRABNER
INSTRUMENTS™**

www.grabner-instruments.com

**MINIFLASH FLP
MINIFLASH FLA**

MINIFLASH FLP

Flash point measurement by Continuously Closed Cup (CCCFP)

The MINIFLASH is a uniquely designed tester for the determination of flashpoints of liquids and solids. The analyzer uses a patented flash detection method of measuring the instantaneous pressure increase inside the continuously closed chamber at the flashpoint temperature. Heating the test chamber from the top avoids condensation of highly volatile compounds, significantly improving the test results. Fast thermoelectric cooling after the test saves expensive labor time.

All measurements are performed according to the latest flash point methods ASTM D6450 & D7094 and the results are equivalent to ASTM D93 Pensky Martens method.



! OFFICIAL ASTM FLASHPOINT COMMITTEE STATEMENT

“There is no statistically significant bias observed between ASTM D7094 and ASTM D93 Procedure A.”

Features

- ASTM D6450 & D7094, US D.O.T. approved
- Excellent correlation to ASTM D93, D56 and ISO 2719
- Maximum Safety - Continuously Closed Cup
- Built-in Peltier temperature control
- Small sample volume of only 2 mL
- Fully automated, fast measurement
- Easy cleaning, no solvents required
- Almost no waste
- Laboratory and field applications
- RS232 interface
- MINIWIN-FLASH software (for PC)

TECHNICAL DATA / MINIFLASH VERSIONS

	SINGLE POSITION UNIT			8 POSITION AUTO-SAMPLER	
	FLP	FLPH	FLPL	FLA	FLAH
Temperature range (+/- 0.2 °C +/- 0.4 °F)	0 to 200 °C (32 to 390 °F)	0 to 400 °C (32 to 750 °F)	-25 to 100 °C (-13 to 212 °F)	0 to 200 °C (32 to 390 °F)	0 to 400 °C (32 to 750 °F)
Fast sample throughput	10 samples per hour			45 min for the unattended measurement of 8 samples	
Sample volume	1 mL (ASTM D6450) / 2 mL (ASTM D7094)				
Interfaces	RS 232 interface for printer and PC and/or LIMS Connector for external keyboard				
Power supply	100/120/230 V AC, 50/60 Hz, 130W (Field application 12V/8A DC)			100/120/230 V AC, 50/60 Hz, 130W	
Dimensions / weight	W x H x D: 196 x 315 x 175 mm (7.7 x 12.4 x 6.9 inch) / 9 kg (20 lbs)			W x H x D: 312 x 402 x 390 mm (12.3 x 15.8 x 15.3 inch) / 20 kg (45 lbs)	

The perfect combination of safety and ease of use

■ No open flame

The MINIFLASH is the only continuously closed cup flashpoint tester that uses a controlled electric arc instead of an open flame. Best of all, only 2 mL of sample are needed for a measurement. These unique features make the Grabner MINIFLASH the safest and most reliable flashpoint tester on the market.

■ No hazardous vapors

During operation hazardous fumes from the heated sample are effectively eliminated. The chamber is continuously closed and the cup is cooled down to the initial temperature before the measuring chamber opens again. Additionally, the active cooling shortens the turnaround time significantly and reduces the risk of injuries.

■ Easy operation

Since MINIFLASH is a fully automatic flashpoint tester, a possible operator bias is eliminated. The sample cup is filled with the liquid and is placed onto the sample cup lift (FLP- series) or on the sample cup tray (FLA-series). RUN is pressed to start the test procedure. The menus can be pre-programmed and locked by the operator.

■ Easy cleaning procedure

The sample cup assembly consists of a sample cup and the sample cup carrier for insulation. The cup rests on three stainless steel pins and is easily removed from the carrier for cleaning.



■ Wide range of applications

With the MINIFLASH the flashpoint is determined over a wide temperature range, to cover all standard closed cup methods as well as GO/NOGO tests. Over the years, the outstanding performance of MINIFLASH has led to widely spread use for compliance with transport regulations/classifications, product specifications and for used oil analysis (programmable fuel dilution curve) in laboratories all over the world.

- Approved by US D.O.T. and RCRA
- Specified for use by NATO, US NAVY, US Marines
- Approved for various ASTM specifications for fuels and oils
- The world wide market leader for the flavors and fragrances industry

MINIFLASH FLA

8 position sampler

With the flashpoint samplers MINIFLASH FLA and FLAH, the manipulation time for 8 different samples is less than 2 minutes. After filling the cups, the fully automatic procedure is started. The samples are measured consecutively with the respective test programs.

Features

- Fully automatic 8 position sampler
- Continuous operation - up to 80 samples per day
- Less than 45 minutes turnaround time for 8 samples



MINIFLASH FLP MINIFLASH FLA

■ MEASURING PRINCIPLE

The Ni-plated aluminium cup **(1)** with a capacity of 7 mL containing the 2 mL sample is lifted to the temperature controlled oven **(2)**, forming the test-chamber with a metal to metal seal. A thermocouple **(3)** is immersed to measure the temperature of the sample. The temperature of the oven is set with Peltier elements **(4)** and an air cooled heat sink. The vapor is ignited by a controlled arc **(5)**.

The flashpoint is detected by the spontaneous pressure increase inside the chamber due to the hot flame **(6)**. A rotating magnet and a small magnet **(7)** inside the chamber provide proper stirring.

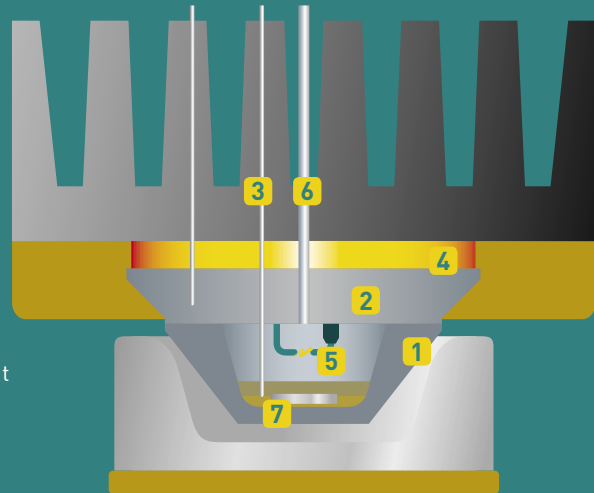

■ MEASURING PROCEDURE

The sample is filled in the sample cup and placed onto the sample cup lift in the front opening of the tester. A small magnet provides stirring of the liquid. Pressing the RUN key lifts the sample cup onto the oven plate, forming the closed measuring chamber.

The measurement is started and the sample is heated in controlled steps. As soon as the sample has reached the starting temperature, the first ignition for a flash test is initiated and the pressure is monitored.

After each ignition, the pressure increase is monitored. When the increase is above the programmed threshold, the measurement is stopped, and the temperature is recorded as the flashpoint temperature of the sample. Results are available directly on the display or can be transferred to a printer or a PC (with the optionally available Windows® software MINIWIN FLASH).



Messtechnik Nfg.
Gesellschaft.m.b.H. & CoKG
A-1220 Vienna/Austria
Dr. Otto-Neurath-Gasse 1
Phone +43/1/282 16 27-0
Fax +43/1/280 73 34
info@grabner-instruments.com
www.grabner-instruments.com