

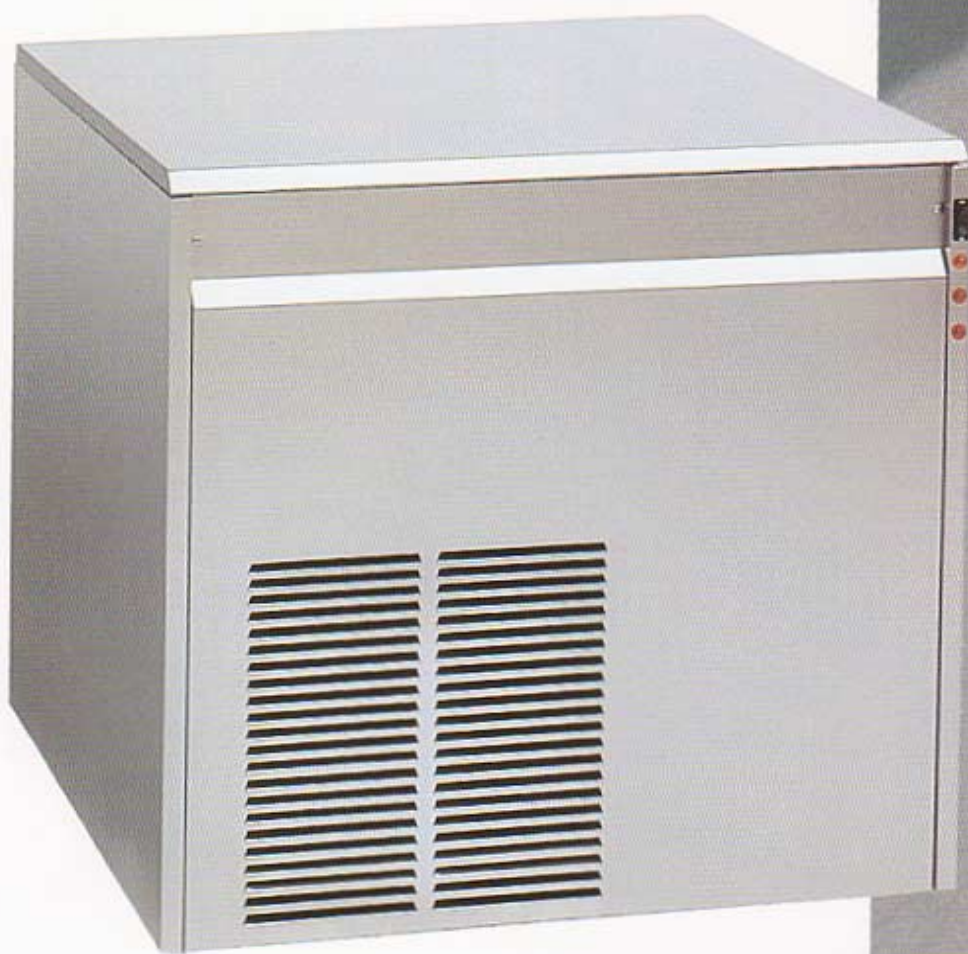

PORKKA

**Automatic Flake Ice
Making Machines**

SERIES KF
SERIES KFP



KF SERIES

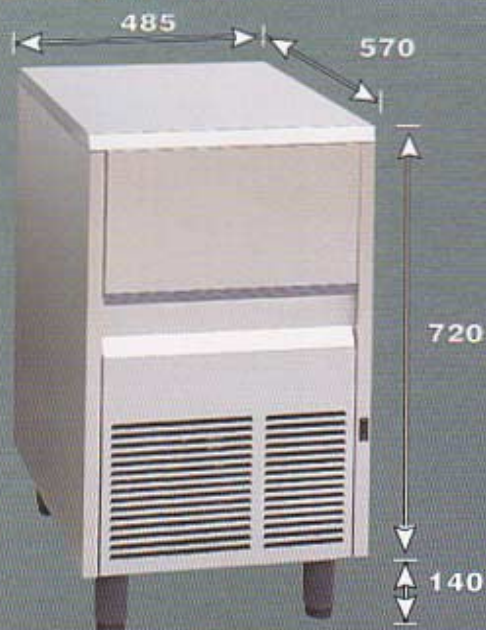

PORKKA KF 75

Air cooled / Water cooled	A	W
Production	Kg/24h Lb/24h	75 165
Bin capacity	Kg - Lb	25-55
Power	(T=43°C) - W	520
Net weight	Kg	54
Gross weight	Kg	62
Volume packing	m ³	0.28
Refrigerant	R134a	
Standard voltage	V230/50Hz/1	

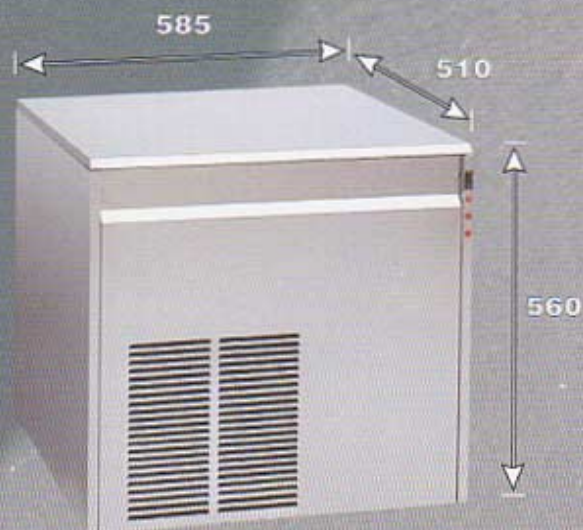

PORKKA KF 180

Air cooled / Water cooled	A	W
Production	Kg/24h Lb/24h	180 396
Bin capacity	Kg - Lb	-
Power	(T=43°C) - W	800
Net weight	Kg	69
Gross weight	Kg	78
Volume packing	m ³	0.27
Refrigerant	R134a	
Standard voltage	V230/50Hz/1	

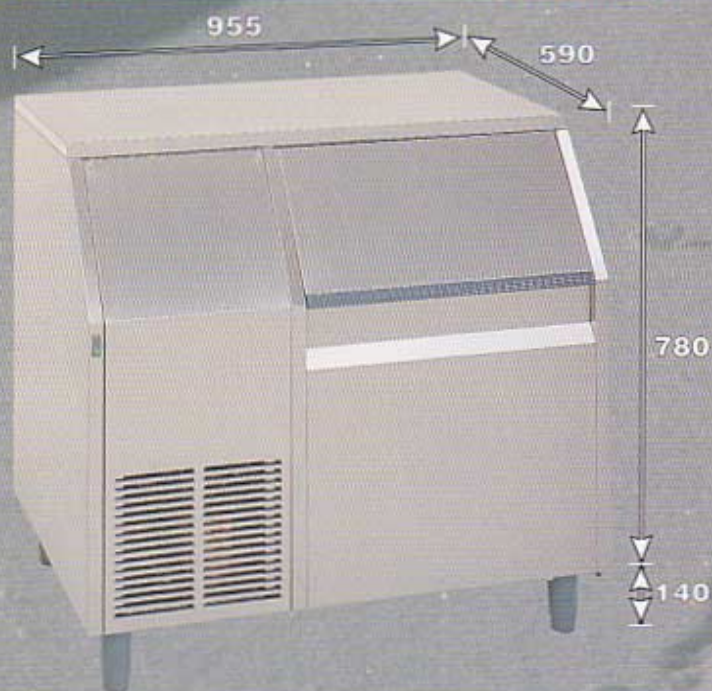

PORKKA KF 165

Air cooled / Water cooled	A	W
Production	Kg/24h Lb/24h	163 359
Bin capacity	Kg - Lb	60-132
Power	(T=43°C) - W	650
Net weight	Kg	81
Gross weight	Kg	94
Volume packing	m ³	0.64
Refrigerant	R134a	
Standard voltage	V230/50Hz/1	

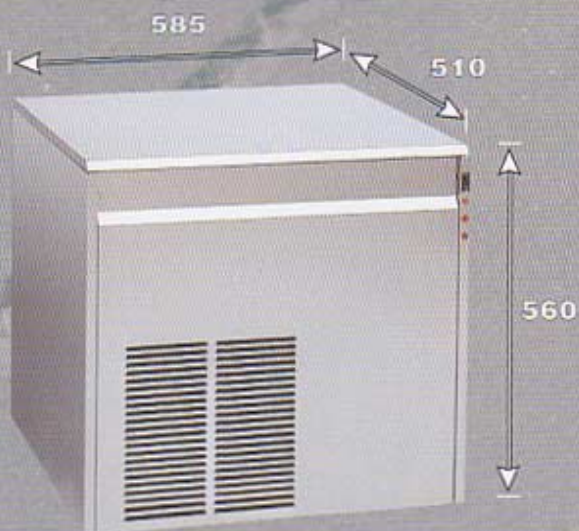

PORKKA KF 250

Air cooled / Water cooled	A	W
Production	Kg/24h Lb/24h	250 550
Bin capacity	Kg - Lb	-
Power	(T=43°C) - W	1150
Net weight	Kg	69
Gross weight	Kg	78
Volume packing	m ³	0.27
Refrigerant	R134a	
Standard voltage	V230/50Hz/1	

KF SERIES

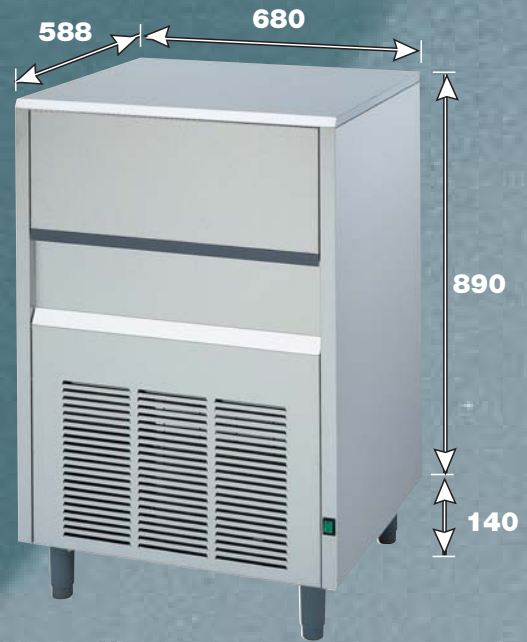
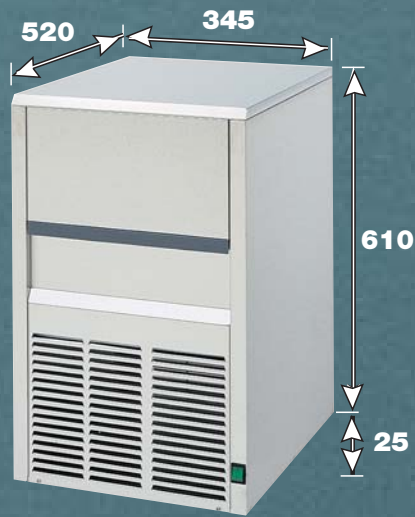

PORKKA KF 35

Air cooled / Water cooled		A	W
Production	Kg/24h	40	42
	Lb/24h	88	92
Bin capacity	Kg - Lb	10-22	
Power	(T=43°C) - W	410	
Net weight	Kg	37	
Gross weight	Kg	41	
Volume packing	m ³	0.16	
Refrigerant		R134A	
Standard voltage		V230/50Hz/1	

PORKKA KF 125

Air cooled / Water cooled		A	W
Production	Kg/24h	125	128
	Lb/24h	275	281
Bin capacity	Kg - Lb	42-92	
Power	(T=43°C) - W	590	
Net weight	Kg	69	
Gross weight	Kg	76	
Volume packing	m ³	0.49	
Refrigerant		R404A	
Standard voltage		V230/50Hz/1	

C O N N E C T I O N S

PORKKA KF 35

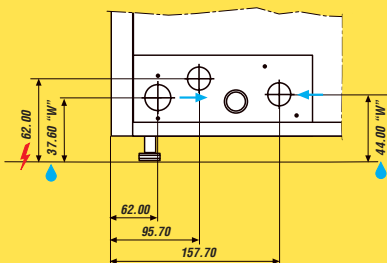

PORKKA KF 125

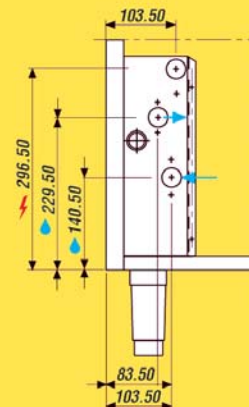

SERIES KF-P

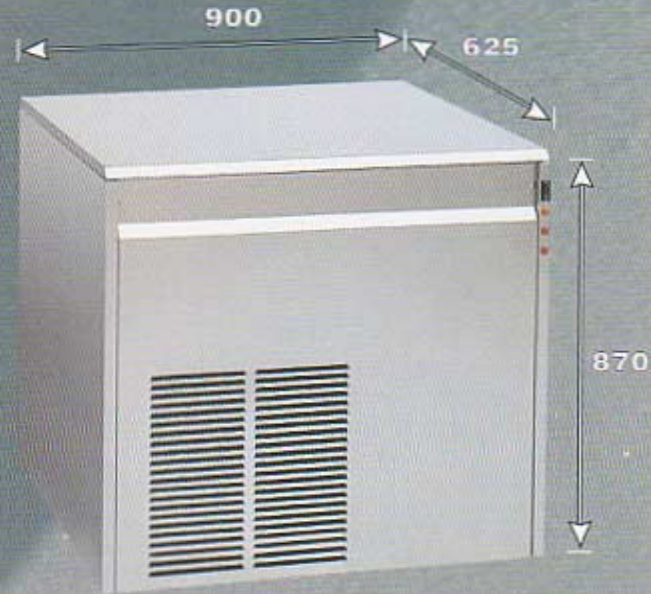
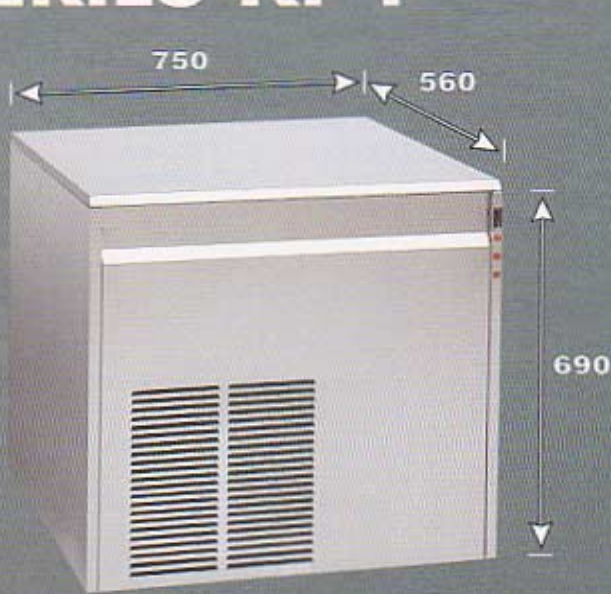

PORKKA KF-P 400

Air cooled / Water cooled		A	W
Production	Kg/24h Lb/24h	450 990	460 1012
Bin capacity	Kg - Lb	-	
Power	(T=43°C) - W	1950	
Net weight	Kg	109	
Gross weight	Kg	122	
Volume packing	m ³	0.44	
Refrigerant		R404A	
Standard voltage		V230/50Hz/1	

PORKKA KF-P 800

Air cooled / Water cooled		A	W
Production	Kg/24h Lb/24h	850 1870	860 1892
Bin capacity	Kg - Lb	-	
Power	(T=43°C) - W	3500	
Net weight	Kg	163	
Gross weight	Kg	180	
Volume packing	m ³	0.70	
Refrigerant		R22/R404A	
Standard voltage		V400/50Hz/3N	

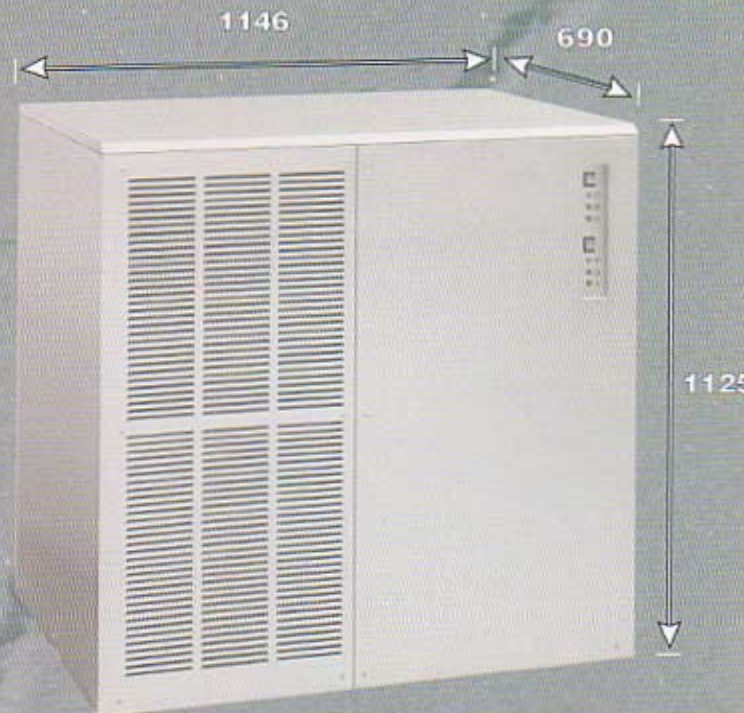

PORKKA		B 250	BF 250
Bin capacity	Kg/Lb	250/550	-
Net weight	Kg.	70	7
Gross weight	Kg.	84	8
Volume packing	m ³	1.12	0.05

PORKKA KF-P 1600

Air cooled / Water cooled		A	W
Production	Kg/24h Lb/24h	1700 3740	1720 3784
Bin capacity	Kg - Lb	-	
Power	(T=43°C) - W	2x3500	
Net weight	Kg	295	
Gross weight	Kg	320	
Volume packing	m ³	0.89	
Refrigerant		R22/R404A	
Standard voltage		V400/50Hz/3N	

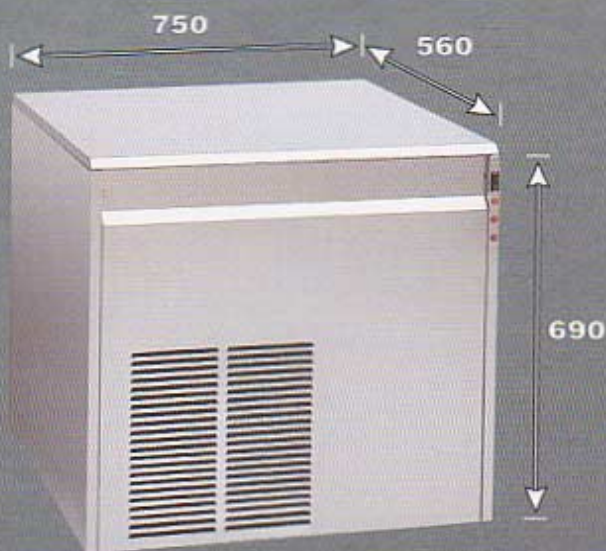

PORKKA KF 500

Air cooled / Water cooled		A	W
Production	Kg/24h	520	525
	Lb/24h	1144	1155
Bin capacity	Kg - Lb	-	
Power	(T=43°C) - W	1950	
Net weight	Kg	109	
Gross weight	Kg	122	
Volume packing	m ³	0.44	
Refrigerant		R404A	
Standard voltage		V230/50Hz/1	

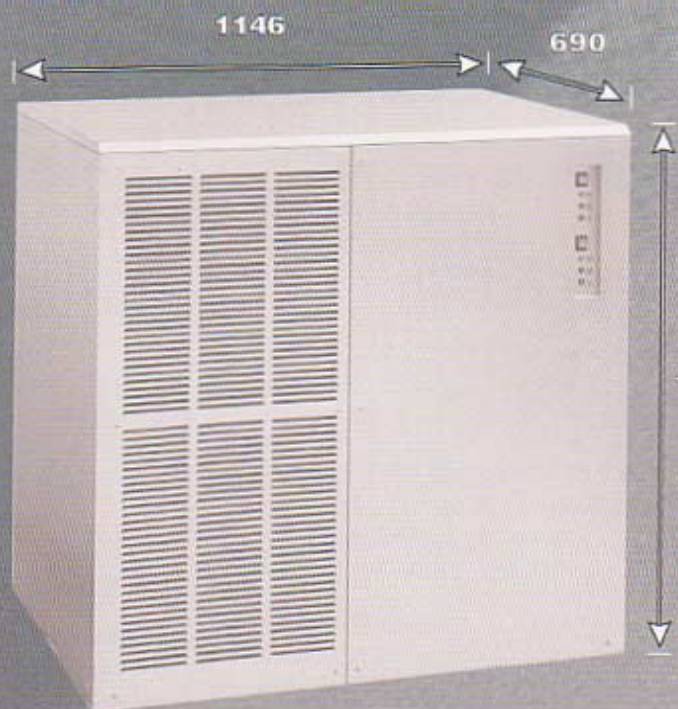

PORKKA KF 2500

Air cooled / Water cooled		A	W
Production	Kg/24h	2350	2375
	Lb/24h	5170	5225
Bin capacity	Kg - Lb	-	
Power	(T=43°C) - W	2x3600	
Net weight	Kg	295	
Gross weight	Kg	320	
Volume packing	m ³	0.89	
Refrigerant		R22/R404A	
Standard voltage		V400/50Hz/3N	

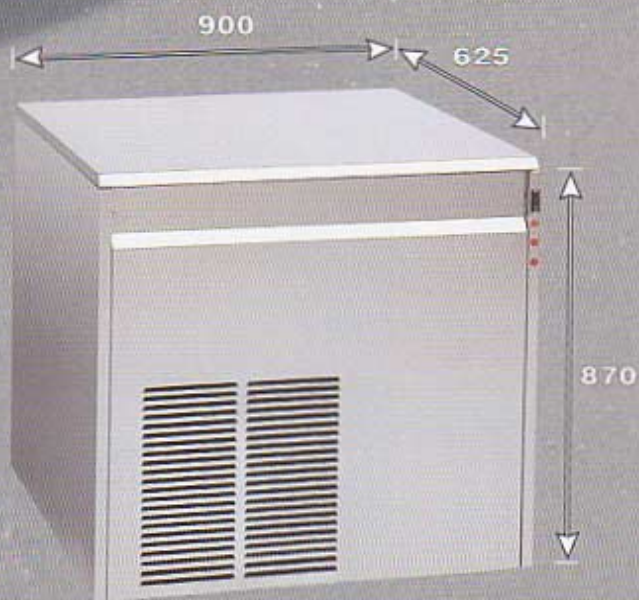

PORKKA KF 1000

Air cooled / Water cooled		A	W
Production	Kg/24h	1150	1165
	Lb/24h	2530	2563
Bin capacity	Kg - Lb	-	
Power	(T=43°C) - W	3600	
Net weight	Kg	163	
Gross weight	Kg	180	
Volume packing	m ³	0.70	
Refrigerant		R22/R404A	
Standard voltage		V400/50Hz/3N	

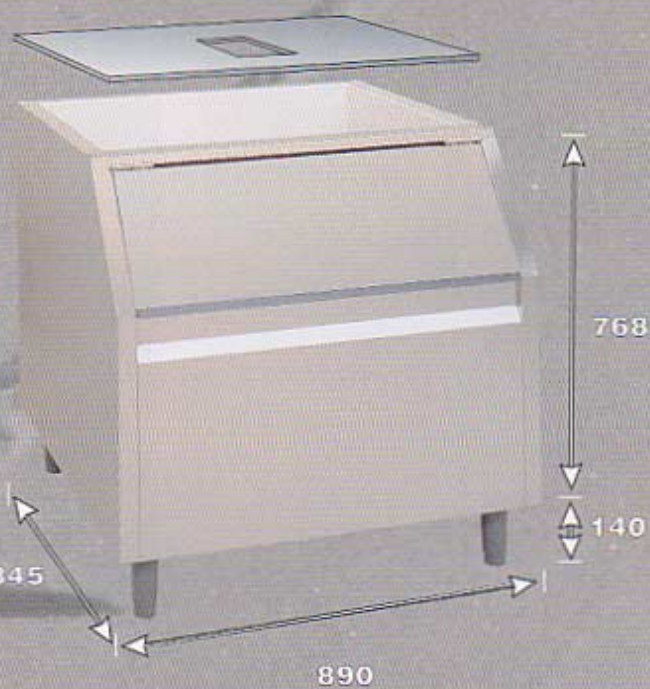

PORKKA

		B 150	BF 150
Bin capacity	Kg/Lb	150/330	-
Net weight	Kg.	53	6
Gross weight	Kg.	63	7
Volume packing	m ³	0.82	0.05

GENERAL INTRODUCTION

Porkka ice flakers produce ice flakes that are dry and compact, this allows the ice to remain free flowing for easy use even after long storage periods. The ice is ideal for use in restaurants and hotels for salad bars, food displays and cocktails. Built using the most up to date technology Porkka ice flakers are designed to produce ice year after year, quietly and efficiently.

PORKKA ICE FLAKERS

Flake ice is used as both an aid to selling as well as prolonging the life of the product being displayed. The machines are cost effective to operate as well as saving the user money, if they are already buying ice from another source.

The auger production system used by Porkka is a tried and tested method of making flake ice and is used by many other manufacturers. One great advantage when selecting Porkka ice flakers is the indirect belt drive system allowing easy access to the whole system for servicing.

THE ICE PRODUCTION METHOD

As the diagram depicts, Porkka machines produce the ice in a vertical evaporator operated by a hermetically sealed compressor, working with environmentally friendly refrigerants. The ice formed on the inner surface is constantly scraped off by the auger (endless screw). As the ice is brought to the top of the chamber excess water is pushed out of the ice, and back into the machine, to be reformed into ice. The auger is driven through a reducing gearbox, to maintain a constant speed and improve the quality of the ice flakes.

The gearbox in turn is driven by a belt drive from an electric motor, eliminating the very expensive self-contained motor and gearbox assemblies used by other manufacturers.



7 Models: KF 75-165-180-250-500 KF1000 and KF2500 produce flake ice using the Auger method. Tried and tested over the years these machines produce quality flake ice at competitive prices.

STANDARD ICE FLAKE

Dry and compact, Porkka ice flake is produced at the ideal temperature of -0.5 deg.C. made from pure drinking water the ice is ideal for use in every process or display that requires hygienic ice, ie; either laboratory or food processing operations.

PRESSED ICE FLAKE

Some operations require harder, drier ice flakes. The Porkka KF-P machines meet these needs, the ice is squeezed at higher pressure to produce harder drier flake ice. This type of ice is preferred, where longer lasting ice is required.

TECHNICAL FEATURES

Porkka ice flakers have been manufactured to the highest specification this includes a body work of high quality stainless steel grade 304 S 01. This eliminates any possibility of rusting when working in harsh environments. All internal components utilised are of either ABS (food grade) plastic or materials for use with potable water. Other features include optional water cooled condensers, should site conditions dictate. The machines which are fully automatic are also fitted with mains on/off switches and a bin thermostat on integral models shuts the system off when the storage bin is full. On modular machines the production is controlled when the storage is full by an electronic eye.

A MULTITUDE OF USES

Porkka ice flake is used in many diverse areas each and every day, some of these fields are;

- **Restaurants and hotels.**
For salad display - cocktails - wine cooling.
- **Supermarkets.**
For wet fish displays - fresh salad and exotic fruit and vegetable displays.

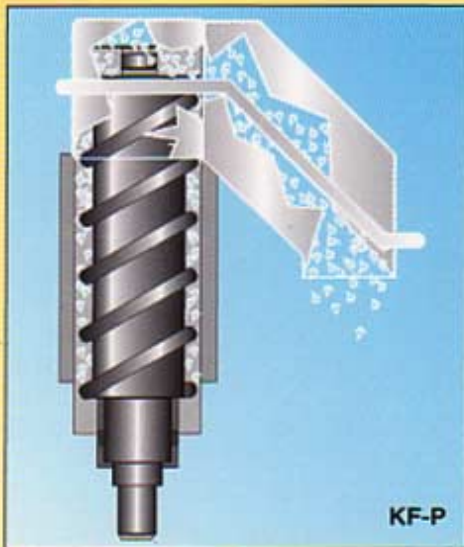

3 Models: KF-P 400-800-1600
KF-P Machines produce pressed flake ice at -0.5°C. This is a drier ice which lasts longer on display and is preferred in some processes.

- **Fishmongers.**

Ice flakes are by far the best display method for wet fish. The ice also prolongs the storage life of the product

- **Butchers and meat processors.**

Ice flakes are the ideal medium for chilling sausage/hamburger meat especially during mincing or grinding process.

It has the advantage of keeping bacterial growth to a minimum, adding shelf-life to the products produced.

- **Bakeries.**

Batch cooling of various mixes to retard proving in the products. Ice is easy to use just mix with the required volume of water in each recipe.

- **Hospitals.**

Ice flakes are used widely throughout hospitals, in physiotherapy departments in heat and cool treatment of injured or diseased limbs - also used in operating theatres to cool body temperatures in major surgery to slow the metabolism.

Chilling during transport of donor organs is yet another use of Porkka ice flakes.

- **Laboratories.**

Calibration of various instruments is another field for Porkka ice flakes, along with many other processes in the modern laboratory.

- **Vegetable growers**

Packing various vegetables with Porkka ice flakes during transport to market, ensures that the product keeps fresher and more moist for longer, therefore allowing sale at grade 'A' quality for higher prices.

Attention:

The production rates indicated are based over a 24 hour period with ambient temperature of +10°C and water temperature of +10°C. If water supply temperature is likely to fall below +5°C the machine can be damaged. Please ask about the Pre-Heater Kit.

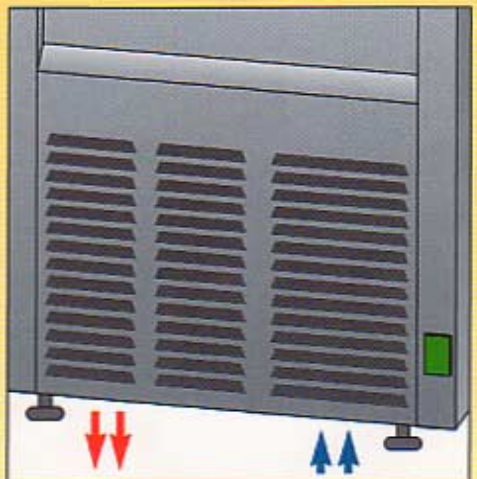

FRONTAL AIR VENTILATION

KF 75F ON REQUEST

The logo for Porkka, featuring a stylized snowflake or starburst symbol to the left of the word 'PORKKA' in a bold, blue, sans-serif font.