

## Specifications

Item	CX31	
Optical system	UIS (Universal Infinity-corrected) optical system	
Illumination	Built-in transmitted Koehler illuminator 6V30W halogen bulb 100-120V/220-240V~ 0.85/0.45A 50/60Hz	
Focusing	<ul style="list-style-type: none"> <li>•Stage height movement by roller guide (rack &amp; pinion)</li> <li>•Stroke per rotation: 36.8mm</li> <li>•Full stroke range: 25mm</li> <li>•Upper limit stopped by simplified pre-focusing dial</li> <li>•Tension adjustment on coarse focus adjustment knob</li> </ul>	
Revolving nosepiece	Fixed quadruple nosepiece with inward tilt	
Binocular observation tube	Field number	20
	Tube inclination	30°
	Interpupillary distance adjustment range	48-75mm
Stage	Size	188(W) x 134(D)mm
	Movement range	76mm X-direction x 50mm Y-direction
	Specimen holder	Double slide holder
	Rubber grip	Equipped as standard
Condenser	Type	Abbe condenser, with built-in daylight filter
	N.A.	1.25 with oil immersion
	Aperture iris diaphragm	Built-in
Dimensions & weight	233(W) x 411(H) x 367.5(D) mm, approximately 8kg (approximately 17.6 lb.)	

## Dimensions

(Unit: mm)

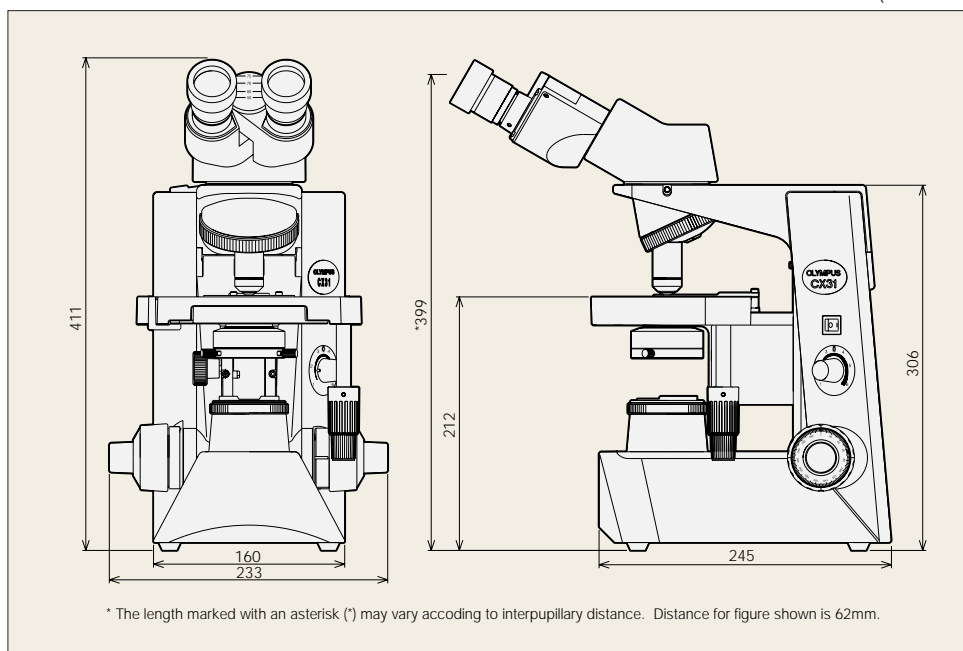

## Objectives, Plan Achromat

PLC	Numerical Aperture (N.A.)	Working Distance (W.D.)
4x	0.10	22.0mm
10x	0.25	10.5mm
40x	0.65	0.56mm
100x Oil	1.25	0.13mm

## Eyepiece

	Field Number (F.N.)
10x	20

Web site address: <http://www.olympus.com>



Specifications are subject to change without any obligation on the part of the manufacturer.

## Olympus business areas

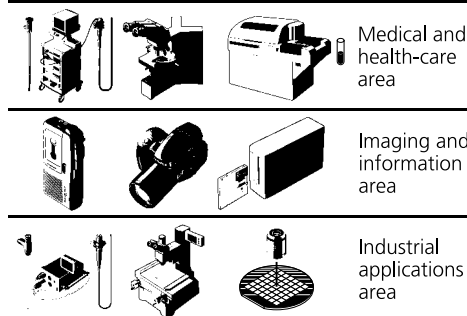

# OLYMPUS®

FOCUS ON LIFE

**OLYMPUS OPTICAL CO., LTD.**  
San-Ei building, 22-2, Nishi-Shinjuku 1-chome, Shinjuku-ku, Tokyo, Japan  
**OLYMPUS OPTICAL CO. (EUROPA) GMBH.**  
Postfach 10 49 08, 20034, Hamburg, Germany  
**OLYMPUS AMERICA INC.**  
2 Corporate Center Drive, Melville, NY 11747-3157, U.S.A.  
**OLYMPUS SINGAPORE PTE LTD.**  
491B River Valley Road, #12-01/04 Valley Point Office Tower, Singapore 248373  
**OLYMPUS OPTICAL CO. (U.K.) LTD.**  
2-8 Honduras Street, London EC1Y 0TX, United Kingdom.  
**OLYMPUS AUSTRALIA PTY. LTD.**  
104 Ferntree Gully Road, Oakleigh, Victoria, 3166, Australia

# OLYMPUS®

Olympus is about life. About photographic innovations that capture precious moments of life. About advanced medical technology that saves lives. About information- and industry-related products that make possible a better living. About adding to the richness and quality of life for everyone. Olympus. Quality products with a **FOCUS ON LIFE**

BIOLOGICAL MICROSCOPE

# CX31

CX2 SERIES

*Sharp, clear images — flat all the way to the edge*

*UIS*  
UNIVERSAL  
INFINITY SYSTEM



# Successor to the CH series bestseller\*,

The Olympus CH biological microscopes, which have gained an outstanding worldwide reputation in many medical and educational arenas, now give rise to the new CX31 with UIS infinity optics.

The Universal Infinity System optics are the same well-known and advanced optical system featured in the highest quality Olympus microscopes.

Evolved from Olympus' best-selling CH series, the new CX models improve all-around performance and offer even greater cost-efficiency.

## Outstanding flat images from Plan C objectives

Use of the newly-developed PLC series of UIS objectives improves flatness dramatically, producing sharp, clear images right up to the edge of the field of view. Ideal for the 10x and 40x objectives so frequently used for inspection work, the flatness ranks among the very best in this class of microscopes.

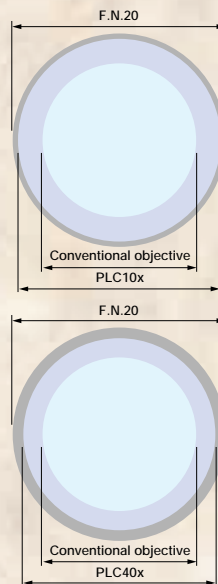
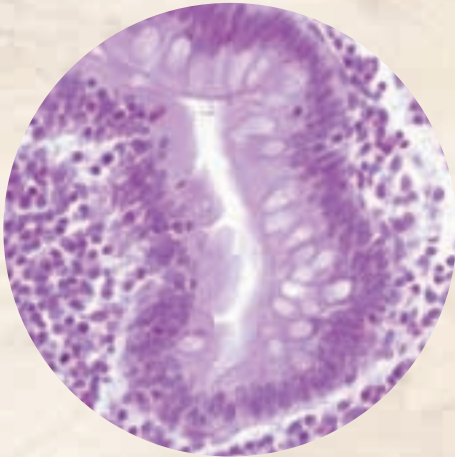

Flatness area comparison

## Bright, even observation images

The illumination system employs a high intensity 6V, 30W halogen lamp for bright images. The aperture iris diaphragm with built-in condenser and standard field stop combine to provide bright and even illumination at all levels of magnification.

## Rigid, durable construction for high performance and long service life

Construction quality is excellent throughout, with objectives, eyepiece, observation tube, revolving nosepiece, highly reliable rackless stage and other components all fixed firmly to the body — so there's nothing to come loose or fall off when the microscope is being transported. The highly reputable rackless stage is employed, and since the X-axis guide does not protrude, both transportation and operation are performed easily and safely.

## Digital imaging compliance

An adapter to mount Olympus digital cameras is provided to allow easy, cost-efficient digital imaging.



## Anti-fungus treatment

The treatment applied to the observation tubes, eyepieces and objectives, protects quality of optical parts even in high humidity regions.



\*Based on shipments of our biological microscopes

# now with advanced UIS optics

## UIS eyepiece

Provides wide field of view (F.N. 20) and allows easy observation with eye glasses.

## Binocular observation tube

Diopter adjustment is performed via the knurled collar on the left eyetube. Wide interpupillary distance adjustment (48-75mm) ensures the best and most comfortable observation conditions for every user.

## Quadruple inward-facing revolving nosepiece

Complies with a wide range of magnifications, allows unrestricted use of the space in front of the objectives and makes it easy to confirm observation positions.

## Coarse upper limit stopper

Locks the upper position of the stage, preventing contact between the objective and the specimen in high magnification observations.

## UIS objectives

4x, 10x, 40x and 100x PLC objectives, providing world-class image flatness.

## Rackless stage

Rack-free stage with no side protrusions. Low-positioned control knob allows smooth and comfortable specimen movement. Scale gradations are in white lettering on a black background.

## Light intensity adjustment

Continuous light adjustments are possible.

## Abbe condenser

An Abbe condenser, with N.A. 1.25 and built-in aperture diaphragm, provides the appropriate diaphragm to suit different specimens and magnifications.

## Field stop

Frame integrated, with ability to accept a  $\varnothing 45\text{mm}$  filter.

## Coaxial coarse/fine focusing knob

The coaxial coarse/fine focusing knob allows each operator to adjust the torque for coarse focusing operations. Focusing is smooth and easy, with the user's hands placed on the desk.

## Stage handle with tactile grips

Tactile grips are fitted to the X and Y stage controls to provide a "light touch" stage movement.

## Highly rigid frame

Extra rigid frame withstands frequent use and repositioning.

## Hand grips for easy portability

Convenient hand grips at the front and back of the frame make it easy to carry the microscope.

