

CKX41/31 specifications

Item	CKX41	CKX31	
Optical system	UIS (Universal Infinity-corrected) optical system		
Focus	Vertical nosepiece movement (stage is fixed), coaxial coarse and fine focus with tension adjustment mechanism, roller slide mechanism, stroke: 7mm up and 2mm down from focus position which is 1mm above the stage, stroke per rotation: 39.6mm (coarse), 0.2mm (fine)		
Revolving nosepiece	Quadruple		
Stage	Plain stage	160mm(L) x 250mm(W), stage clips attachable	
		Exchangeable insert plate (ø25mm opening) incorporated	
		ø35 petri dish holder stage incorporated	
	Mechanical stage	Right-hand low drive coaxial controls, stage movement: X=120mm, Y=78mm, with three dish/sample holders	
	Substage	70(L) X180(W)mm	
Illumination system	Light source	6V,30W halogen lamp, lamp socket (U-LS30-3-2), built-in frosted and heat absorbing filters, detachable illuminator	
	Filter holder	Insert up to 11mm thick with ø45mm filter, detachable	
	Aperture diaphragm	Lever type, range: from minimum ø3mm to maximum ø44mm	
	Slider insertion	With phase slider pocket and built-in slider position click stop mechanism	
Condenser	Detachables ultra-long working distance condenser (N.A. 0.3, W.D. 72mm)		
Contrast slider	<ul style="list-style-type: none"> Pre-centered phase-contrast: 4X, 10X/20X/40X, empty slot Centerable phase-contrast: 4X, 10X/20X, empty slot (40X optional, pre-centered) Centerable for Relief Contrast: 10X, 20X, 40X 		
Observation tube	Binocular tube	U-CBI30-2: inclined 30°, interpupillary distance range: 48-75mm, diopter adjustment by helicoid on left sleeve (F.N. 20) U-BI30-2: inclined 30°, interpupillary distance range: 48-75mm, diopter adjustment by helicoid on left sleeve (F.N. 22)	Fixed binocular tube, inclined 45°, interpupillary distance range: 48-75mm, diopter adjustment by helicoid on right sleeve
	Trinocular tube	U-CTR30-2 and U-TR30-2: inclined 30°, ring dovetail attachment, interpupillary distance range: 48-75mm, tube length and diopter adjustment by helicoid on left sleeve Observation optical path: 50(binocular)/50(video port) (F.N. 20)	
	Tilting binocular tube	CKX-TBI: variable inclination angles from 30° to 60°, interpupillary distance range: 50-76mm, diopter adjustment by helicoid on right sleeve (F.N. 20)	
		U-TBI-3: variable inclination angles from 5° to 35°, circular mounting dovetail attachment, interpupillary distance range: 50-76mm, diopter adjustment by helicoid on right sleeve. (F.N. 22)	
Fluorescent illuminator	Detachables illuminator, switchable slide (3-position: B excitation, G excitation, empty slot or U excitation)		
Fluorescence light source	50W Mercury		
Eyepiece	For U-CBI30-2/U-CTR30-2/U-CTBI: WHB10X/WHB10X-H (F.N. 20) For U-BI30-2/U-TR30-2/U/TBI3: WH10X/WH10X-H/35WH10X/ PWH10X (F.N. 22)	10X (F.N.: 20)	
Power supply	Continuous intensity adjustment, built-in voltage changeover switch (100/120V, 220/240V), frequency 50/60Hz		

Objective lens specifications

	Objective	N.A.	W.D.(mm)	Remarks
For brightfield	PLC4X	0.10	22.0	
	PLC10X	0.25	10.5	
	ACH20X	0.40	3.0	
	LCPLFL40X	0.60	2.6	
For phase-contrast	UPLFL4XPH	0.13	17.0	PHL (for use with IX2-SL)
	CPL10XPH	0.25	9.8	PHC (for use with IX2-SL)
	PL10XPH	0.25	10.5	PH1 (for use with IX2-SL)
	LCACH20XPH	0.40	3.2	PHC (for use with IX2-SL)
	LCPLFL20XPH	0.40	6.9	PH1 (for use with IX2-SL)
	LCACH40X2PH	0.55	2.3	PH2 (for use with IX2-SL)
	LCPLFL40XPH	0.60	2.6	Cover correction 0-2.6mm of exchangeable caps PH2 (for use with IX2-SLP)
	UPLFL4XPHP*	0.13	17.0	For use with IX2-SLP
	CACH10XPHP*	0.25	8.8	For use with IX2-SLP
	LCACH20XPHP*	0.40	3.2	For use with IX2-SLP
	LCACH40XPHP*	0.55	2.3	For use with IX2-SLP
	For RC	CPL10XRC	0.25	9.5
LCACH40XRC		0.40	2.8	For use with CKX-RC
LCACH40XRC		0.55	1.9	For use with CKX-RC
For FL	UPLFL4X	0.13	17.0	U,B,G
	UPLFL10X	0.30	10.0	U,B,G
	UPLFL20X	0.50	1.6	U,B,G
	LCPLFL20X	0.40	6.9	B,G
	LUCPLFL40X	0.60	2.7-4.0	

* Pre-centering objective

Dimensions (mm)

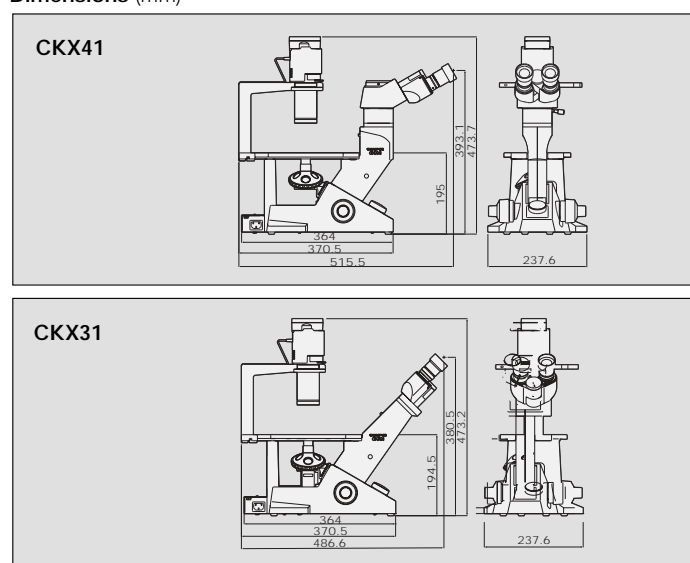

Specifications are subject to change without any obligation on the part of the manufacturer.

OLYMPUS

OLYMPUS OPTICAL CO. (EUROPA) GMBH

Postfach 104908, D-20034 Hamburg
Wendenstraße 14-18, D-20097 Hamburg
Tel.: +49 40 23 77 30
Fax: +49 40 23 77 36 47
E-mail: microscopy@olympus-europa.com
www.olympus-europa.com

OLYMPUS

THE VISIBLE DIFFERENCE

Inverted Microscopes

CKX41/31

CKX SERIES

Inverted Microscopes for Routine Use



The CKX Series: Convenience, Performance and Flexibility



Both improved optical performance and more convenient operation are delivered by the CKX31 and CKX41. The CKX31 is a cost-effective microscope for cell observation, whilst the CKX41 allows upgrading to more advanced operations.

The new CKX Series is based on intensive study of user requirements worldwide. The result is a choice of routine microscope systems to give you high quality images easily and effectively. Convenience in use is central to the design of the microscope frame, viewing tube and controls. Innovative developments in UIS optics have enabled Olympus to deliver improved performance and new capabilities. And the flexible modular approach allows the user to commit to the CKX Series without being cut off from valuable new microscopy techniques.



As your microscope needs grow, the CKX41 can grow with you by incorporating modular add-on units for fluorescence, documentation with digital cameras and more.

The CKX Series: Convenience, Performance and Flexibility



For a quick and easy visual check in a busy laboratory the high angle tilting head allows you to use the microscope on the move.



New UIS objectives give better contrast, resolution and working distances.

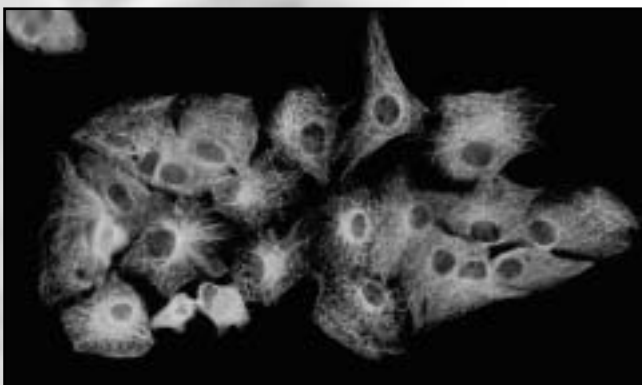

The latest techniques such as fluorescence are within reach even on a routine system.

Comfort in use

The delicate set-up of the phase annulus for phase contrast work has long been an irritating task for novice microscopists. Now Olympus has made this time-consuming configuration unnecessary with a pre-centered slider. The modern understanding of ergonomics has been applied in the design of the CKX Series to give a number of new features making your life easier. These include low and frontal controls, and a unique tilting binocular tube.



Breakthrough in optics

Improved optical performance throughout includes new UIS objectives for phase and relief contrast. The result is outstandingly high contrast images. Phase contrast, transmission and resolution are all improved. The CKX Series with powerful 30W illumination provides significantly enhanced image quality and brightness for the observation of cells. The new relief contrast technique provides improved imaging for IVF and cell viability assessment.



Stability and adaptability

A robust frame with triangular base and solid front and back stage supports gives exceptional stability. In order to give routine users the freedom to expand their activities Olympus has taken a modular approach to the design of the CKX41. Fluorescence (e.g. GFP imaging) can be carried out with an add-on unit. Documentation of images can be carried out by incorporating the CKX41 into various Olympus systems for photographic capture, video monitoring or digital imaging. Specialist cell culture techniques can be incorporated with different holders for a variety of vessels.

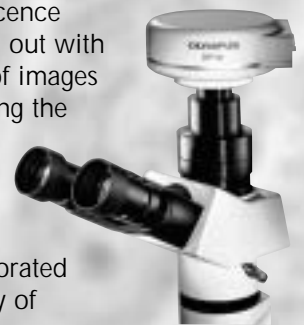

Comfort in Use

- Common and centering-free phase contrast annulus
- Unique tilting head



By eliminating many of the time-consuming and sensitive adjustments that have traditionally been required for phase contrast work we have made microscopy quicker and easier.

With the CKX Series a new range of UIS objectives and a pre-aligned phase contrast slider have been introduced.

The specimen can be viewed immediately without using adjustment pins.

The slider has an additional benefit – the user can adjust the magnification without adjusting the slider. A common phase annulus is used for 10x, 20x and 40x magnifications. The same slider has an alternative annulus for 4x magnification, and a brightfield position.

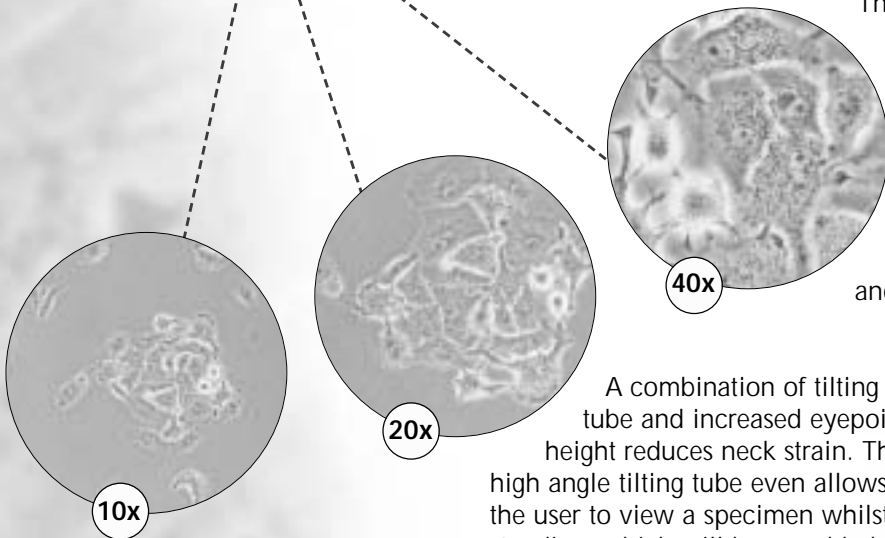

Flexible observation at different magnifications without centering adjustment at the slider.

A combination of tilting tube and increased eyepoint height reduces neck strain. The high angle tilting tube even allows the user to view a specimen whilst standing, which will be an added convenience for rapid checking of cell cultures.

Low control positioning and front knobs and switches have been incorporated to make long term use more comfortable.



No more adjustment pins with precentered UIS phase contrast.

The compact design and small footprint of the CKX Series make it more convenient for use in safety cabinets and clean benches as well as taking up less laboratory space.



Tilting tube accessory for rapid comfort and even viewing while standing up.



Breakthrough in Optics

- UIS objectives with outstanding contrast, resolution and working distance
- New RC relief contrast for unstained and living specimen

Phase Contrast

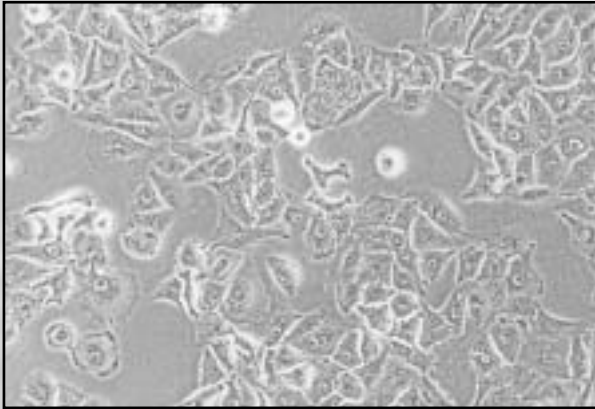

A549 cells in "multiwells":
observed with CRL 10x/0.25 PHC

The Olympus UIS optics now also introduced with the new CKX Series offer outstanding contrast, resolution and working distance. Special 10x objectives have been developed to optimize the "meniscus-surface" problem for phase contrast in microtitre plates. 20x or 40x objectives are available with cover correction function for glass slides, Petri dishes, microtiter plates and perfusion chambers.

In addition Olympus has developed a new relief contrast (RC) technique which has particular advantages for the observation of cell viability in unstained living specimens. The new technique uses a modulated oblique illumination to increase visibility and contrast. The combined modulator within the condenser and phase contrast objective enhances a pseudo-relief effect and allows superb apparent three-dimensional images particularly if plastic Petri dishes and other cell culture devices are used. Contrast and brightness can easily be defined by changing the position of the condenser slit.

Relief Contrast

New relief contrast system
from Olympus:
Pollen in honey left behind
by a honey bee

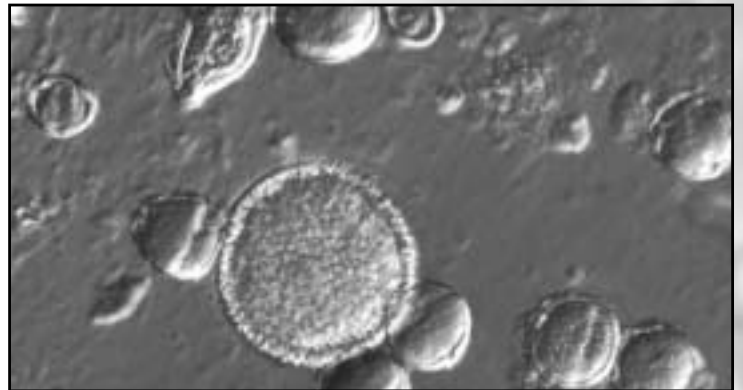

• Relief Contrast (RC) Theory

The use of a modulated oblique illumination allows a three dimensionally appearing of the image to be obtained.

The RC technique is introduced to increase visibility and contrast in unstained and living material particularly if plastic Petri dishes and cell culture devices are used.

Contrast and brightness can easily be defined by changing the position of the condenser slit.

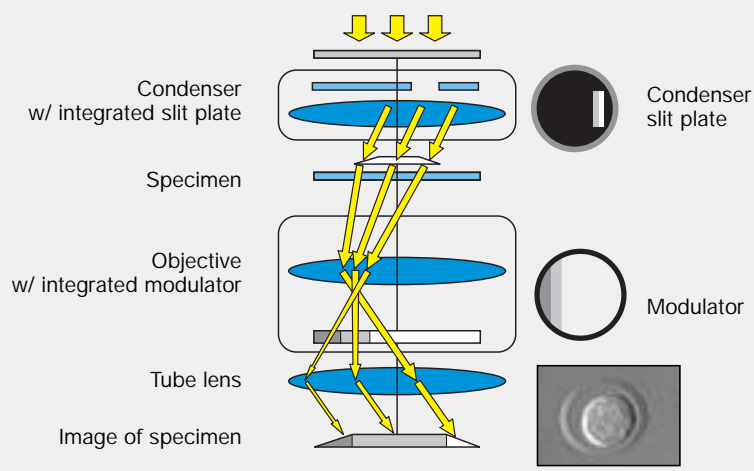

Stability and Adaptability

- Solid and stable frame design
- Fluorescence and digital camera upgradability

The robust frame includes a triangular base and extra thick stage support at both front and back. The illumination pillar is mounted directly on the stage to give added stability. The CKX Series has been developed to accommodate a wide variety of special cell culture and imaging needs.

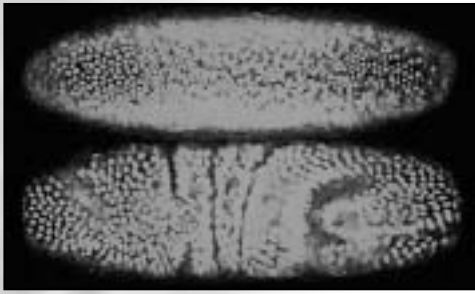

Fluorescence or GFP imaging can be carried out with an add-on unit.

Fluorescence is in increasing demand even for routine operations. Olympus has developed a cost-effective 50W Mercury system as add-on unit for the CKX41 that delivers images of outstanding brightness and clarity. Blue and green excitation filter combinations are available together with an brightfield position on a 3 position slider. In addition a new filter combination can be offered for UV excitation (DAPI etc.) as option.

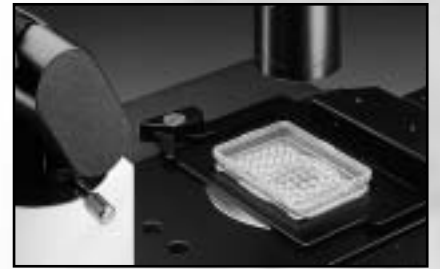

The mechanical stage comes with different holders and stage inserts for roller bottles, tissue culture flasks, Petri dishes, microtitre plates and hemacytometer. There are also stage extension plates and a glass stage insert simplifies cleaning on the CKX41.

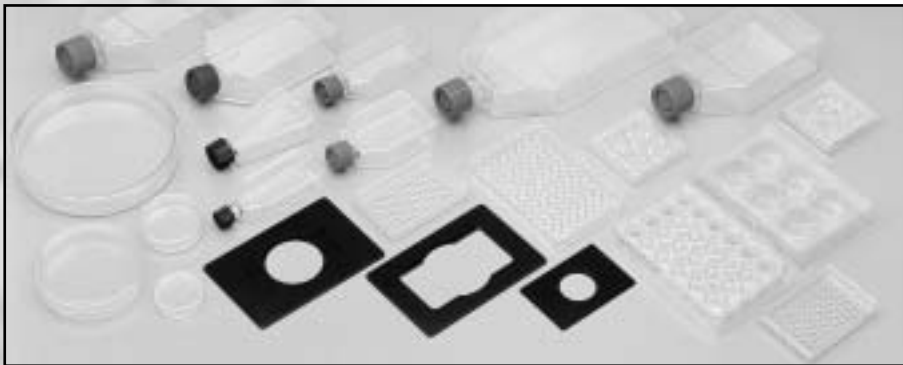

Documentation Adaptability

If you need documentation on your cells for archiving, presentations or posters the CKX41 can be used with Olympus DP12 camera, video adapter and digital imaging systems. Optionally an eyepiece sleeve adapter can be used to install Olympus Camedia cameras on CKX31.

CKX41/31 System diagram

