

NEX HD

The ultimate, heavy duty arm for tough applications



NEX HD has a patented ball joint hood suspension. This, in combination with the parallelogram construction, enables an easy and precise manoeuvrability of hood and arm.

Nederman NEX HD with a Ø 200 mm hose is the ultimate arm for heavy duty welding, metal spraying and grinding. The aluminium hood resists high temperatures. Typical applications are workplaces in the metal fabrication industries where large airflows is needed.

- The arm can rotate 360°
- Perfectly balanced and simple to position
- External support mechanism for optimal suction efficiency
- Encapsulated arm support mechanism – protects the arm against dust and dirt
- Can be mounted on brackets, extension arms and exhaust rails
- Can be connected to a single fan or a central system
- Equipped with a damper in the hood – saves energy when not in operation
- Hood with integrated lamp and start/stop switch for fan (accessory)
- The design of the hood ensures very high capture capacity and a low noise level

Arm lengths: _____ 2, 3, 4, 5 m
 Ducting diameter: _____ Ø200 mm
 Recommended airflow: _____ 1000 - 1900 m³/h
 Max temp of extracted air: _____ +120°C

Art. No:
 2 m: _____ 10560232
 3 m: _____ 10560332
 4 m: _____ 10560432
 5 m: _____ 10560532

Dimensions NEX HD Extraction Arm

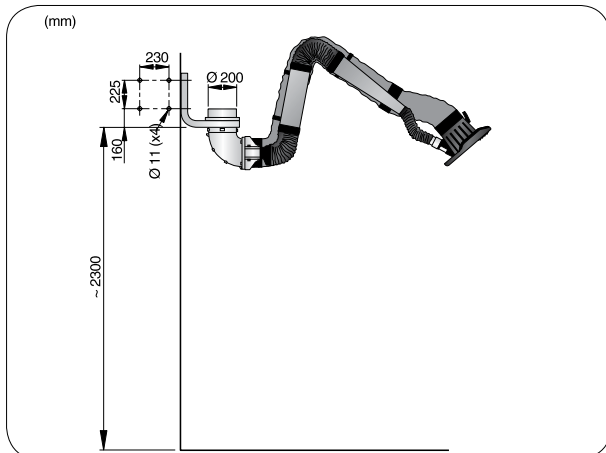

Pressure drop NEX HD Extraction Arm

