

Infinity®



Certified to DIN EN 12469 by TÜV-NORD

*Infinity Class II, Microbiological Safety Cabinet,  
Model FC2-4A1, with optional support stand.*

## **Class II, Microbiological Safety Cabinets**

*The Industry's Premier Biological Safety Solution from Esco*



**ESCO**

WORLD CLASS. WORLDWIDE.

Infinity.



## Main Features

Unique Dynamic Chamber™ plenum with angled filter delivers superb airflow uniformity with deviation no greater than 6% of average downflow, exceeding European Standard EN 12469 by more than three times.

- Negative pressure plenum surrounds contaminated positive pressure plenum; no fabric bags are used.

- Dual fan design for guaranteed safety. If one fan fails, minimal protection is still maintained with only one fan running.

Esco next-generation Sentinel™ microprocessor supervises all cabinet functions.

A large easy-to-read digital display and ergonomically sized touchpad controls improve user interface.

Fully closable, motorized sash provides an airtight seal for better safety when cabinet is inoperative overnight.

Integrated HPV port with convenient side access panel for Hydrogen Peroxide Decontamination.

Frameless, shatterproof sash is easier to clean, offers larger, unobstructed viewing area.

Ergonomically angled front improves reach and comfort.

Multi-piece work surface removal simplifies cleaning.

- Single-piece work surface with sump that contains spillage is also available as an option.

Raised armrest maintains safety by preventing blockage.

Esco **ISOCIDE™** antimicrobial coating on all painted surfaces minimizes contamination.

Available in 1.2 and 1.8 meter models (4' and 6').  
Shown with optional telescoping stand.



Certified to EN 12469 by TÜV-NORD, Germany for safety and performance (FC2-4A1).

Infinity.

Biological Safety Cabinets • Class II Microbiological Safety Cabinet

- Downflow air sensor mounted in interior.
- Accuflow™ microprocessor speed controller maintains safe cabinet airflow despite supply voltage fluctuations.
- Integrated RFI and electrical noise filters eliminate interference with and from adjacent equipment.
- Low noise level <58dBA (1.2 meter (4') cabinet) is significantly quieter than conventional cabinets.
- Dual, long-life ULPA (per IEST-RP-CC001.3) filters for supply and exhaust airflow.
- Enhanced side-capture zones optimize containment.
- Independent exhaust sensor mounted exterior to work area.
- Single piece interior side and back wall construction.
- Improved lighting is brighter, more uniform and reduces glare.
- Optional UV lamp operates on programmable timer.
- HPV-compliant and approved for safe decontamination using BIOQUELL technology.



- The front sash is motorized for convenient one-hand operation. The sash control is mounted on the front control panel.
- Integrated sash proximity contacts sense proper sash position, serve as an interlock for the UV lamp, and activate an alarm if the sash is improperly positioned.
- When fully lowered the sash seals automatically against a closed-cell peripheral gasket to isolate the interior and prevent escape of contaminants during decontamination.



### Motorized Front Sash Assembly and Sash Seal

- The magnetic switch eliminates the chance of mechanical wear and tear typical of a mechanical switch.
- The laminated glass maintains containment if the sash is accidentally broken during cabinet operation.
- The back of the sash can be easily cleaned by removing the sash track cover to swing up the sash glass.



A graphical interface indicates cabinet performance.

Display language can be user-programmed for English and German.

Enlarged, multi-line digital read-out with alpha-numeric display indicates all input, status and alarm functions.

Indicators for filter life and UV life are reverse scaled from 100% to 0% and displayed on the LCD panel.

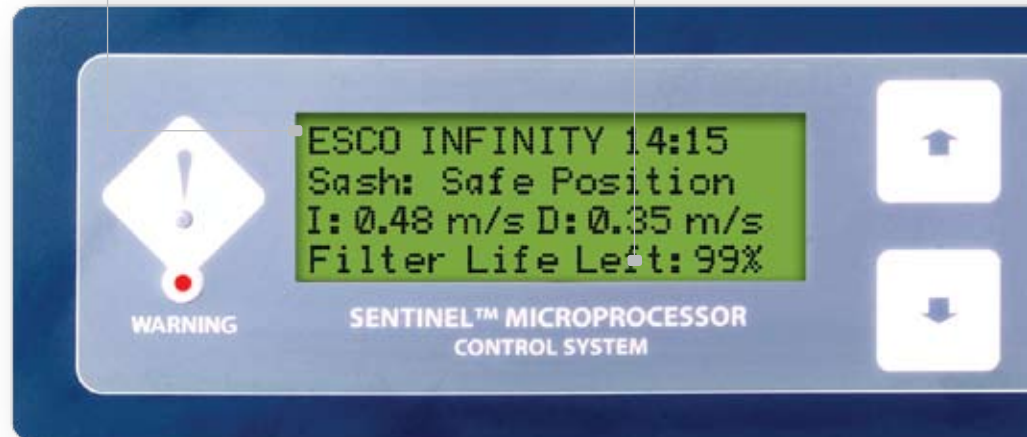

### Operator, Product and Environmental Protection

Infinity Class II Model FC2-4A1 delivers three times better downflow uniformity than required by European Standard EN 12469, and provides protection from airborne contaminants to the operator, product and the environment. Model FC2-4A1 shown with optional height adjustable stand with casters and optional adjustable footrest.

- When programmed ON
  - the start-up sequence confirms status with Air Safe and local time display.
  - the Personal Identification Number (PIN) access restricts unauthorized adjustments.
  - an airflow alarm warns of deviations from normal velocities.

### Advanced Engineering

The Esco Infinity® Class II microbiological safety cabinet includes a number of design and performance features not found on our popular Labculture® series cabinets. These include:

- An aerosol tight window for additional safety while the cabinet is inoperative.
- Double fan design guarantees safety in the event of the failure of one fan.
- Motorized front sash for one-hand operation.
- Larger LCD display for easy monitoring of operational parameters.
- Reduced height permits cabinet installation for seated operation in standard 2.4 meter (nominal, <8') laboratory ceiling height. Cabinet shown on optional mounting stand with casters, seated height work surface 711 mm (28").

### Containment and Protection

The Esco Infinity Class II microbiological safety cabinet (FC2) provides operator, product and environmental protection against Biosafety Levels 1, 2 and 3. This cabinet can be used for handling Biosafety Level 4, provided that the operator wears positive pressure suit.

- The airflow ratio of 65% recirculation to 35% exhaust increases operator protection beyond the 70% / 30% ratio of conventional microbiological safety cabinets.
- Inflow of room air enters the front air grille to establish operator protection; room air does not enter the work zone, preventing product contamination.
- Raised armrest prevents the likelihood of inflow grille blocking by operator's arms.

- Auto-purge slots located at the front side walls eliminate eddy currents and dead air pockets in the critical area behind the sash window.
- The downflow (supply) filter is tilted proportionally to the cabinet front angle to direct more air forward to the front air grille.
- The inflow velocity, downflow velocity, airflow path and intake geometry are precision tuned and tested to create an optimum air curtain on the front aperture; this curtain maintains personal and product protection even in the unlikely event of a severe inflow or downflow imbalance that would compromise protection in a conventional cabinet.

### Integrated Filtration System

Independent supply and exhaust filters provide 99.999% typical efficiency for particle sizes of 0.1 to 0.3 microns. Infinity Series filters meet the IEST-RP-CC001.3 recommended practice for ULPA performance (USA), and EN 1822 for H14 performance (EU).

- ULPA filters (per IEST-RP-CC001.3), are tested to a typical efficiency of >99.999% for 0.1 to 0.3 micron particles; these provide better filtration capability than conventional H13 HEPA filters that have a typical efficiency of > 99.99% for 0.3 micron particles.

4

(%) Typical Penetration

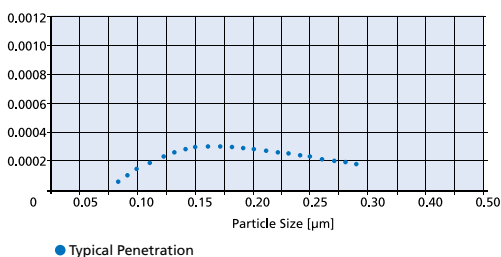

### Esco Filter Efficiency

Independent supply and exhaust filters provide 99.999% typical efficiency for particle sizes of 0.1 to 0.3 microns. Infinity Series filters meet the IEST-RP-CC001.3 recommended practice for ULPA performance (USA), and EN 1822 for H14 performance (EU).

Color coded indicator lamps display green for fan operation; blue for fluorescent lights and electrical outlet; and orange for UV lamp ON caution.

Programmable automatic UV light timer simplifies operation, enhances contamination control, extends UV lamp life and saves energy.



Enlarged touchpad data entry buttons with tactile feedback permit control settings and access to diagnostics, default settings and hierarchical menus.

## Esco Next-Generation Sentinel Microprocessor Control System

- The Sentinel microprocessor-based control and alarm system supervises all cabinet functions.
- Setpoints and other applications are user activated through touch-pad programming access detailed in the Operations Manual.
- A key switch located on the cabinet prevents unauthorized use of the cabinet.
- The motorized sash is controlled by an up/down button.
- A data output for remote monitoring and information management to meet FDA21CFR and other criteria is available; contact Esco or your Sales Representative for details.

### Mini-pleat Separatorless Filter (left) vs. Conventional Aluminium Separator Filter (right)



Esco cabinets use Swedish Camfil Farr® mini-pleat filters without aluminum separators to increase filter efficiency, minimize the chance of leakage, and to prolong filter life. Filters include a lightweight aluminum frame for structural stability and elimination of swelling common to conventional wood frames.

- Filter assembly is constructed in accordance with EN1822 requirements.
- The supply filter provides ISO Class 3 (per ISO14644.1) clean air to the work surface in a gentle vertical laminar flow for product protection.
- Modern separatorless mini-pleat filter construction maximizes the filter surface area to extend filter life and eliminate possible filter media damage by thin and sharp aluminum separators used in conventional HEPA filter construction.
- The exhaust filter traps biohazard particles acquired from the work surface before air is exhausted to the room, offering personal and environmental protection.

- The exhaust filter media is protected from mechanical damage by an integrated metal screen guard, which is absent from conventional HEPA filters.

### Sentinel Microprocessor Control, Alarm, Monitoring System

The Esco Sentinel microprocessor-based control system supervises operation of all cabinet functions.

- Continuous monitoring of cabinet airflow is displayed on a bright, easy-to-read LCD panel. The large display monitors operational parameters.
- The control panel is located on the center of the cabinet, and angled down for easy access by the operator.
- A back-up battery maintains alarm function for airflow, power and pressure alarm in the event of a power failure.

- Two integrated, temperature-compensated true airflow velocity sensors provide independent measurement of inflow and downflow velocities despite room temperature fluctuation.
- All electronic parts are contained inside a plug-and-play module that permits easy exchange if required.
- Microprocessor software updates are available from Esco for download via the Internet.
- Sentinel functions are factory set to default (ON or OFF), depending on worldwide destination and local preferences. Default settings can be user activated through the touchpad data entry access.

5

### Esco Accuflow Microprocessor Speed Controller

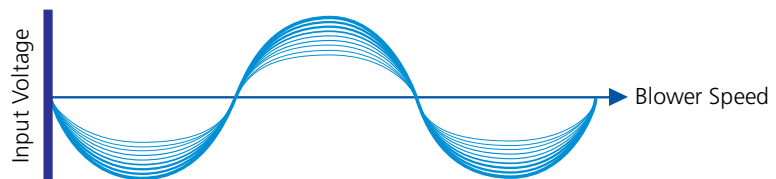

The Esco Accuflow™ microprocessor speed controller maintains steady motor/blower speed despite building voltage fluctuations, thereby assuring constant face velocity and downflow for optimum safety, containment and protection.

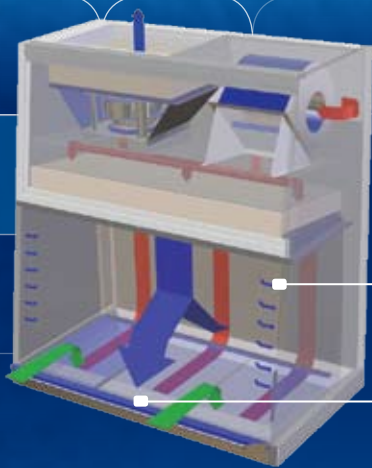

## Cabinet Filtration System

Side capture zones

Dynamic air barrier, inflow and forward-directed downflow air converge

- Ambient air is pulled through the perforations located towards the work zone front to prevent contamination of the work surface and work product. The inflow does not mix with the clean air within the cabinet work zone. Inflow air travels through a return path toward the common air plenum (blower plenum) at the top of the cabinet.
- Approximately 35% of the air in the common plenum is exhausted through the ULPA filter to the room. The remaining 65% of the air is passed through the downflow ULPA filter and into the work area as a vertical laminar flow air stream bathing the work surface in clean air.
- The uniform, non-turbulent air stream protects against cross contamination within and throughout the work area.
- Near the work surface, the downflow air stream splits with a portion moving toward the front air grille, and the remainder moving to the rear air grille. A small portion of the ULPA filtered downflow enters the intake perforations at the side capture zones at a higher velocity (small blue arrows).
- A combination of inflow and downflow air streams forms an air barrier that prevents contaminated room air from entering the work zone, and prevents work surface emissions from escaping the work zone.
- Air returns to the common air plenum where the 35% exhaust and 65% recirculation process is continued.

- ULPA-filtered air
- Unfiltered / potentially contaminated air
- Room air / Inflow air

6

- Automatic start-up sequence will prepare the cabinet for normal operation and advise when safe conditions are established.
- An administrator controlled PIN (Personal Identification Number) can be set to restrict access to main menu.
- The airflow alarm can be activated or deactivated depending on user preference and nature of the work.

Consult your Esco Operating Manual or contact Esco or your Sales Representative for information on user-preference programming capabilities built into the Sentinel microprocessor platform.

### Redundant Blower System

The Infinity blower system is designed for high performance operation, redundancy, maximum energy efficiency and minimal maintenance.

- Dual permanently lubricated direct-drive external rotor motor/blowers safety in the event of a motor failure.
- The external rotor motor design allows for optimum cooling of the motor during extended operations and extends the motor bearing life.
- The inflow and downflow balance is precisely established by two independent Accuflow fan speed controls.
- The Accuflow microprocessor based speed controller maintains constant, stable airflow despite building supply voltage fluctuations.
- Built-in RFI and electrical noise filters eliminate interference with adjacent instrumentation.
- An integral blower hour meter tracks operating life and aids in predictive maintenance planning.

- To prevent fan damage, a paper-catch grille traps papers or towels that may drop down on the drain pan, preventing them from being pulled into the column by fan suction.

### Cabinet Construction

Robust construction and enhanced safety features qualify the cabinet for the most demanding laboratory applications. The cabinet is fully assembled and ready to install and operate when shipped.

- The interior sides and back wall are formed from a single piece of stainless-steel with large radius corners to simplify interior cleaning.
- The cabinet work zone has no welded joints to collect contaminants or rust.
- All stainless steel work surfaces are accessible for cleaning.
- Multi-piece tray components are easily lifted and removed to encourage surface decontamination.
- A recessed central area and stainless steel drain pan channels spills and prevent liquids from entering the lower filtration and blower systems.

### Esco Centrifugal Fan with External Rotor Motor (left) vs. Conventional Fan with Standard Motor (right)

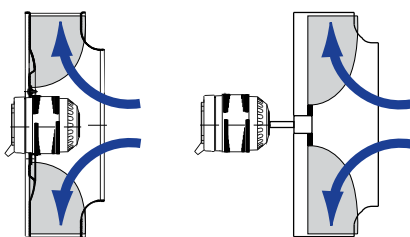

Esco Infinity cabinets use a combination of high performance scroll blowers (supply) and German made ebm-papst® permanently lubricated, centrifugal motor/blowers with external rotor designs (exhaust). Selected for energy efficiency, compact design, and flat profile, the completely integrated exhaust blower assembly optimizes motor cooling, with unified rotating parts and overall component balance for smooth, quiet, vibration-free operation. Weight is equally distributed to all bearings to extend bearing life, transfer heat and maximize speed control.

## Double Blower System

Provides the maximum possible level of safety by enabling safe cabinet shut down in the event of a single blower failure.

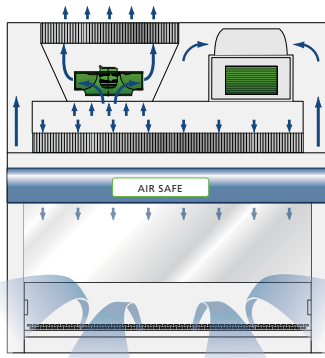

**1A:** Under normal operation with both blowers operating (1a) the supply blower creates a negative pressure surrounding the contaminated positive pressure plenum and pushes air across the supply and exhaust filters. The exhaust blower boosts the air pressure through the exhaust filter to create better inflow and operator protection.

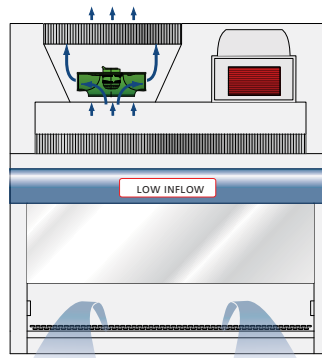

**1B:** If the supply blower fails (1b), downflow to the work area is suspended. The control panel warns of low inflow and downflow failure. The exhaust blower still can provide inflow and some containment to the cabinet.

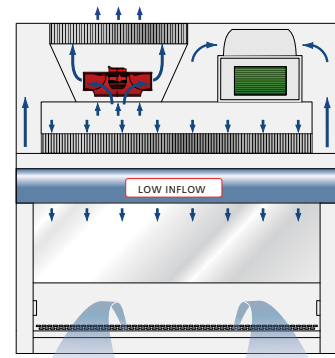

**1C:** If the exhaust blower fails (1c), the supply blower continues to provide inflow to the cabinet and downflow to the work area. The control panel warns of low inflow. With the exhaust blower offline, the cabinet maintains protection by maintaining inflow above 0.40 m/s as required by EN 12469.

### Dynamic Chamber™ Plenum Design



■ Negative pressure ■ Positive pressure

The Esco triple-wall design creates a Dynamic Chamber plenum which surrounds contaminated areas with negative pressure, preventing the possibility of contamination from leaks in filter seal, gasket or cabinet structure. The third wall conceals utilities.

- External surfaces are coated with Esco Isocide antimicrobial coating to protect against surface contamination and inhibit bacterial growth. Isocide eliminates 99.9% of surface bacteria within 24 hours of exposure.
- There are no screws in the front or sides to trap contaminants or complicate cleaning.

### Service Fitting Access

The cabinet is pre-plumbed for easy installation when the optional gas and/or vacuum fittings are ordered; see Accessories.

- The Service fitting openings are offset for easier access.

- The External plumbing is concealed behind trim panels to preserve cabinet aesthetics.
- A normally closed gas solenoid valve automatically shuts off gas flow in the event of a cabinet alarm or unsafe condition.

*Note: The gas solenoid valve and plumbing are installed only when the optional gas tap is ordered.*

### Comfortable Ergonomic Design

The cabinet is engineered for comfort, utility value and safety.

- The angled viewing window and narrow profile front grille improves reach into the work area.
- The instant-start 5000k fluorescent lamp operates on an electronic ballast to reduce heat, improve comfort and conserve energy.
- The lamp delivers uniform lighting to the work surface for greater comfort, reduced glare and improved productivity; see Specifications.
- The front armrest is raised above the work zone to improve comfort and to minimize blockage of forward airflow perforations.
- The optional adjustable support stand provides work surface height control.
- The frameless sash eliminates blockage of operator's line of sight.
- A generous sash opening allows for

easier access into the work zone, provides ample room for transferring of small equipment; see Specifications.

- The sliding window can be fully opened to insert and remove larger instrumentation and equipment.

### Testing and Certification

All components meet or exceed applicable safety requirements.

- Each cabinet is individually factory tested for electrical safety.
- Documentation specific to each cabinet serial number is maintained on file.
- Tested to EN 12469, the renowned world standard for microbiological safety cabinets.
- Certified to DIN EN 12469 by TÜV-NORD CERT GmbH (FC2-4A1).
- Contact Esco or your Sales Representative for site preparation information; see Electrical Specifications.

### Warranty

The Infinity is warranted for 3 years excluding consumable parts and accessories.

- Each cabinet is shipped with a comprehensive User Manual complete with a report documenting all test procedures.
- Additional IQ/OQ documentation is available upon request.
- Contact your local Sales Representative for specific warranty details or documentation requests.

Standards Compliance	Microbiological Safety Cabinets	Air Quality	Filtration	Electrical Safety
	EN 12469	ISO 14644.1 Class 3, Worldwide AS 1386 Class 1.5, Australia JIS B9920 Class 3, Japan	IEST-RP-CC034.1, USA IEST-RP-CC007.1, USA IEST-RP-CC001.3, USA EN 1822, Europe	IEC 61010-1, Worldwide EN 61010-1, Europe UL 61010-1, USA CAN/CSA-C22.2 No. 61010-1

## Accessories and Options

Esco offers a variety of options and accessories to meet local applications. Contact Esco or your local Sales Representative for ordering information.

### Single Piece Work Tray

Available for applications where a recessed work surface is desired to contain spillage. Must be specified when ordering.

### Electrical Outlets and Utility Fittings

- Electrical outlet, Euro/Worldwide
- Petcock (air, gas, vacuum)
  - Euro/Worldwide style DIN 12898, DIN 12919, DIN 3537
  - The gas solenoid valve is installed when the gas petcock is ordered

### Support Stands

- Fixed height, available 737 mm (29") or 838 mm (33"),  $\pm 38.1$  mm (1.5")
  - With leveling feet
  - With casters

*Note: The FC2-4A1 cabinet was certified by TÜV-NORD only with the fixed height leveling feet support stands (29" and 33").*

- Adjustable height, hydraulic range from 737 mm (29") to 838 mm (33")
  - Manual or electrical lift
  - With casters
- Telescoping height, nominal range from 737 mm (29") to 838 mm (33")
  - Adjustable in 25.4 mm (1") increments
- Infinitely adjustable cradle stand, with casters
  - Elevates to seating or standing work surface height
  - When lowered, permits movement through standard doorway

*Note: Increases exterior dimensions.*

### Cabinet Accessories

- PVC armrest
  - Chemically treated, improves operator comfort, easy-to-clean, 711 mm (28") standard size
- Ergonomic lab chair
  - Laboratory grade construction, meets Class 100 cleanliness; alcohol resistant PVC materials
  - Adjustable 395-490 mm (15.6"-19.3")

- Germicidal UV lamp
  - Controlled by automatic UV lamp timer through Sentinel microprocessor control panel
  - Emission of 253.7 nanometers for most efficient decontamination
  - Lamp is positioned away from operator's line-of-sight for safety and proper exposure to interior surfaces

*Note: UV lamp intensity reduces over time and its effectiveness is subject to factors such as relative humidity in the cabinet, ambient air temperature and microbial species in the work zone.*
- Ergonomic foot rest
  - Angled, helps maintain proper posture
  - Adjustable height
  - Anti-skid coating, chemical resistant finish
- IV Bar, with hooks
  - Stainless steel construction
  - Available for all standard cabinets
- Microscope viewing device
  - Mounting and viewing pouch integrated into sash
  - Factory installed; specify when ordering

8

## Robust Cabinet Construction and Enhanced Safety Features



Built-in HPV port for easy decontamination with Hydrogen Peroxide.



Service fixtures are offset for easier reach. Standard cabinets include two fixture provisions on each sidewall. Electrical outlets are mounted below service fixtures to minimize obstructions.



The one piece stainless steel side wall is radiused at corners and without crevices or joints, facilitating cleaning.

- Helpful for certifiers, the hinged maintenance assembly opens to a fixed position on integrated, gas spring struts providing front service access.

All key components with the exception of the motor/blower assembly are mounted outside the air stream and away from contaminated air to permit service without decontamination. These include fluorescent lamps, UV lamps, electrical harnesses, electronic boards and microprocessor control.

- Panels enclosing potentially hazardous areas or components such as microbiological contamination or electrical shock are color-coded red to warn service technicians.

- The telescoping Dynamic Chamber™ plenum minimizes physical lifting and accelerates filter change when required.

- Work area containment is maintained even when removable components are lifted out for cleaning.

The lower drain trough is a single-piece fabrication with wide open angles and a channel to direct spills to the drain.

Infinity

Biological Safety Cabinets • Class II Microbiological Safety Cabinet

# Model FC2 Microbiological Safety Cabinet Technical Specifications

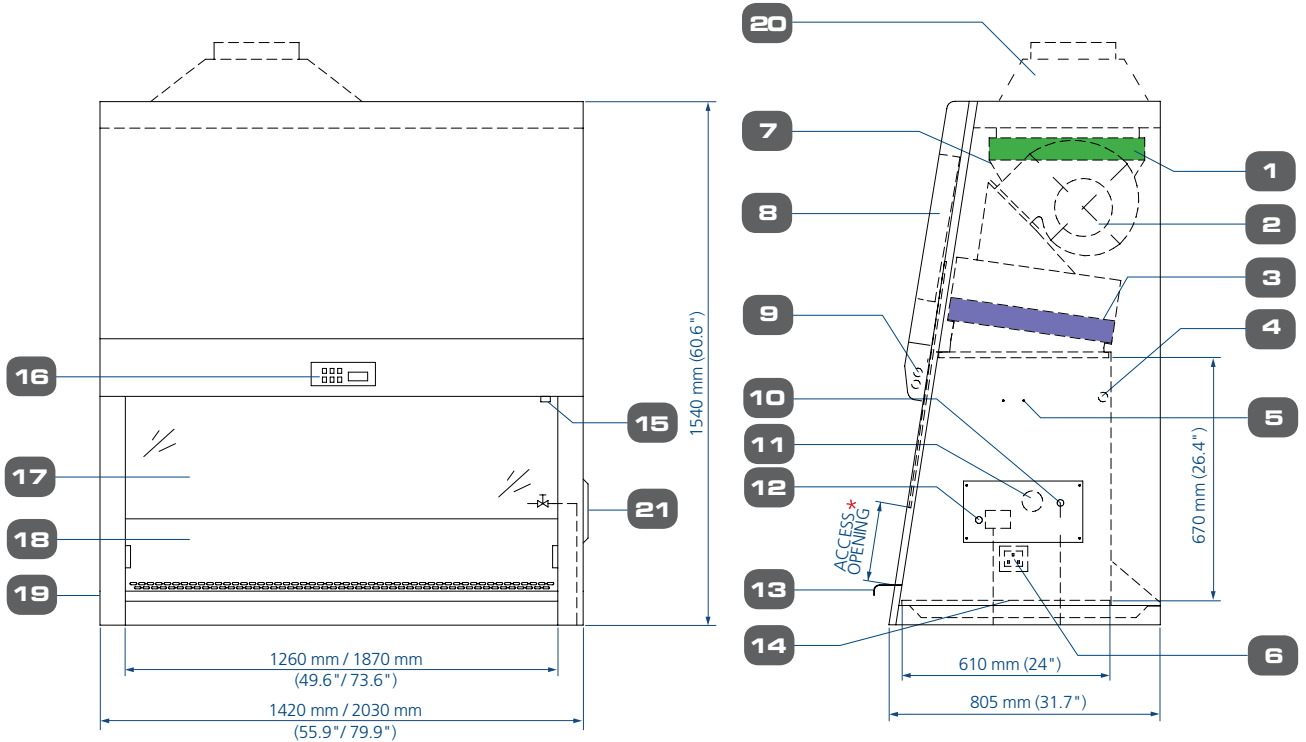

- 1. Exhaust filter
- 2. Blower
- 3. Downflow filter
- 4. Standard UV light Retrofit Kit™ provision
- 5. Standard IV-Bar Retrofit Kit provision
- 6. Universal electrical outlet (1.2 and 1.8 meter / 4' & 6' models - two single outlets in work zone)
- 7. Exhaust fan
- 8. Electrical / Electronics panel
- 9. Fluorescent light
- 10. Gas service fixture with solenoid valve (optional)
- 11. HPV port
- 12. Vacuum service fixture
- 13. Stainless steel single-piece work tray
- 14. Stainless steel armrest
- 15. Key switch
- 16. Esco Sentinel microprocessor control system
- 17. Motorized sliding sash (aerosol tight)
- 18. Single piece stainless steel back wall and side wall
- 19. Side removable panel for plumbing access
- 20. Thimble exhaust collar (optional)
- 21. HPV inlet cover plate

*Access Opening Height	All Model Sizes
Testing Opening Height	200 mm (7.9")
Working Area Height	210 mm (8.3")

\*The combination of the Esco raised armrest and recessed work surface creates additional space within the working area than typically specified.

## Optional Exhaust Collar Positions for Thimble-Ducting for FC2 Models

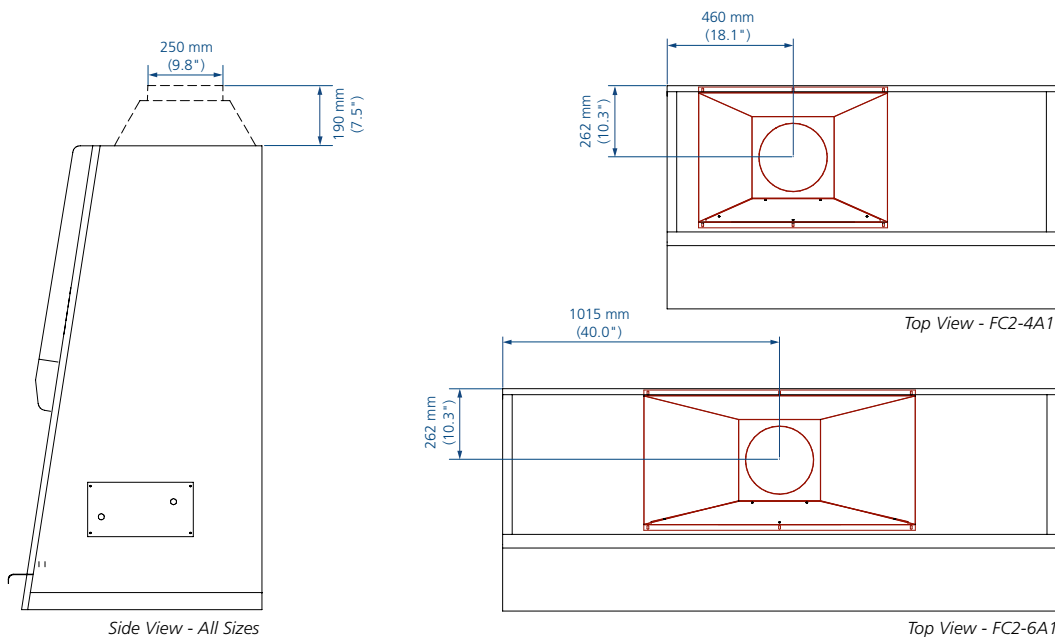

## General Specifications, Infinity Class II Microbiological Safety Cabinets

Model		FC2-4A1	FC2-6A1
Nominal Size		1.2 meters (4')	1.8 meters (6')
External Dimensions (W x D x H)		1420 x 805 x 1535 mm 56.0" x 31.7" x 60.4"	2030 x 805 x 1535 mm 80.0" x 31.7" x 60.4"
Internal Work Area Dimensions (W x D x H)		1260 x 610 x 670 mm 49.6" x 24.0" x 26.4"	1870 x 610 x 670 mm 73.6" x 24.0" x 26.4"
Internal Work Space Area		0.62 m <sup>2</sup> (6.67 sq.ft.)	0.92 m <sup>2</sup> (9.90 sq.ft.)
Tested Opening		200 mm (7.9")	200 mm (7.9")
Working Opening		210 mm (8.3")	210 mm (8.3")
Average Airflow Velocity	Inflow	0.48 m/s (95 fpm) at initial setpoint	0.53 m/s (105 fpm) at initial setpoint
	Downflow	0.35m/s (70 fpm) at initial setpoint	
Airflow Volume	Inflow	437 m <sup>3</sup> /h (257 cfm)	714 m <sup>3</sup> /h (420 cfm)
	Downflow	929 m <sup>3</sup> /h (544 cfm)	1367 m <sup>3</sup> /h (804 cfm)
	Exhaust	437 m <sup>3</sup> /h (257 cfm)	714 m <sup>3</sup> /h (420 cfm)
Sound Emission (Typical)	NSF 49	<61 dBA	<60 dBA
	EN 12469	<58 dBA	<57 dBA
ULPA Filter Typical Efficiency	Downflow	>99.999% at 0.1 to 0.3 microns as per IEST-RP-CC001.3 USA >99.995% at MPPS as per EN 1822 (H-14) EU	
	Exhaust		
Fluorescent Lamp Intensity		> 1200 Lux (111 foot-candles)	
Cabinet Construction	Main Body	1.2 mm (0.05") 18 gauge electrogalvanized steel with white oven-baked epoxy Isocide antimicrobial powder coated finish	
	Work Surface	1.5 mm (0.06") 16 gauge stainless steel, type 304, with 4B finish	
	Side Walls and Drain Pan	0.9 mm (0.035") 20 gauge stainless steel, type 304, with 4B finish	
Electrical (220-240V, AC, 50Hz, 1Ø)	Cabinet Power/ Amp	810 W/ 4.5 A	1400 W/ 8 A
	Outlet Amp Fuse	5 A	5 A
	Total Amp	9.5 A	13 A
	BTU/ Hr	1652	2856
Net Weight *		298 kg / 657 lbs	447 kg / 985 lbs
Shipping Weight *		354 kg / 780 lbs	522 kg / 1150 lbs
Shipping Dimensions, Maximum (W x D x H) *		1530 x 900 x 1870 mm 60.2" x 35.4" x 73.6"	2150 x 900 x 1870 mm 84.6" x 35.4" x 73.6"
Shipping Volume, Maximum *		2.58 m <sup>3</sup> (91 cu.ft.)	3.62 m <sup>3</sup> (128 cu.ft.)

\* Cabinet only, excludes optional stand.

### Microbiological Testing

Esco performs testing in accordance with more than 10 of the world's most recognized standards for local, regional and international criteria. Testing in our micro-biology laboratory is conducted according to NSF49, EN12469, and JIS K3800. An NSF-accredited biohazard cabinet field certifier is available in-house full-time to supervise all testing work, using harmless *Bacillus atrophaeus* (formerly *Bacillus Subtilis*) bacteria that is used to challenge the cabinet, then incubated for 48 hours and the Colony Forming Units (CFU) are counted to determine the testing results. Increased microbiological challenge tests with objects inside the cabinet work zone, Bunsen burner, external airflow disturbance, and Human-As-Mannequin test adapted from Fume Hood development were performed to simulate real-world conditions.

### Personnel Protection Test

The test objective is to evaluate the safety of the cabinet for the personnel operating on potentially hazardous samples in the cabinet work zone.

- A nebulizer containing 55 mL of 5 to 8 x 10<sup>8</sup> spores/mL *B.atrophaeus* spores is placed inside the work zone, 10 cm (4") behind the front opening sash.
- Target slit air samplers and impingers are placed outside the work zone to capture possibly escaping *B.atrophaeus* spores, then the sample is incubated.
- Acceptance: The number of *Bacillus atrophaeus* CFU recovered from the agar plates shall not exceed 10 CFU per test.

### Product Protection Test

The test objective is to determine cabinet protection to the product/samples inside the cabinet work zone from environmental contaminants.

- A nebulizer containing 55 mL of 5 to 8 x 10<sup>6</sup> spores/mL *B.atrophaeus* is placed at 10 cm (4") in front of sash window.
- Target agar plates are placed throughout the entire work surface.
- Acceptance: The number of *Bacillus atrophaeus* CFU recovered from the agar plates shall not exceed 5 CFU per test.

### Cross Contamination Test

The test objective is to evaluate cabinet protection from cross contamination of samples placed simultaneously inside the work zone.

- A nebulizer containing 55 mL of 5 to 8 x 10<sup>4</sup> spores/mL is placed against one of the work zone sidewalls.
- Target agar plates are placed 360 mm (14") away from the same side wall.
- Acceptance: The number of *Bacillus atrophaeus* CFU recovered on agar plates shall not exceed 2 CFU per test.

### HPV Test Compliant: Safer Hydrogen Peroxide Decontamination Compatibility

Esco biological safety cabinets are Hydrogen Peroxide Vapor (HPV) compliant and decontaminatable cabinets approved by BIOQUELL for this patented process. HPV is a safer and more efficient alternative to conventional decontamination using formaldehyde (CH<sub>2</sub>O):

- HPV is non-carcinogenic and odorless, while formaldehyde is carcinogenic, toxic and has pungent smell.
- If there is a gap on the cabinet sealing, escaping HPV to the lab will decompose to become oxygen and water. Escaping formaldehyde, however, is harmful to people in the lab. Therefore HPV decontamination can be performed while people are working inside the lab, while formaldehyde decontamination must be performed with no one present in the lab. The HPV method improves safety, productivity, and reduces the time to seal the cabinet.
- HPV biological efficacy is independent of environmental variables, whereas formaldehyde efficacy is dependent on such variables.
- HPV has a better penetration capacity, resulting in a full decontamination of the cabinet. The formaldehyde method is known to result in incomplete decontamination.
- HPV is more effective and rapid against biological organisms compared to formaldehyde.

- HPV requires approximately 4-7 hours for set-up, decontamination, and tear-down, compared to a total of 12-15 hours needed to complete a formaldehyde decontamination process.
- HPV decontamination effectiveness is independent of temperature and humidity. Formaldehyde requires temperature above 20°C and relative humidity above 65%.
- For information on the BIOQUELL HPV methodology contact Esco or your Sales Representative.

### KI-Discus Containment Test According to EN 12469:2000 (Operator Protection)

Esco is currently one of the few companies in the world equipped to perform the KI-Discus test for our customers. The KI-Discus test is defined in the European Standard for microbiological safety cabinets, EN12469:2000, as a test method for validating the operator/personnel protection capabilities of the cabinet.

- The KI-Discus test shows excellent correlation with the microbiological test method for operator protection, and is useful for validating the actual containment performance of the cabinet on-site.
- The KI-Discus takes only 45 minutes as opposed to 2 days for microbiological testing.
- Esco Infinity FC2 models are factory tested on a sampling basis using the KI-Discus method for operator safety.



*Esco builds quality from the inside out.*

## Comprehensive Performance Testing At Esco



*Every Infinity model manufactured by Esco is individually tested, documented by serial number and validated with the following test methods.*

- Inflow/downflow velocity
- PAO Aerosol challenge for filter integrity
- Light, noise and vibration
- Airflow pattern visualization
- Electrical safety to IEC61010-1
- Additional KI-Discus containment and microbiological testing is performed on statistical sampling basis.



**Esco Containment, Clean Air and Laboratory Equipment Products**

- Biological Safety Cabinets, Class II, III
- Fume Hoods, Conventional, High Performance, Ductless Carbon Filtered
- Laminar Flow Cabinets, Horizontal, Vertical, PCR
- Animal Containment Workstations
- Hospital Pharmacy Isolators, Cytotoxic Safety Cabinets
- Specialty Workstations: *In-Vitro* Fertilization, Powder Weighing
- PCR Thermal Cyclers, Conventional, Real-Time
- Cleanroom Fan Filter Units, Modular Rooms, Air Showers, Pass Thrus

*Since 1978, Esco has emerged as a leader in the development of controlled environment, laboratory and cleanroom equipment solutions. Products sold in more than 100 countries include biological safety cabinets, fume hoods, ductless fume hoods, laminar flow clean benches, animal containment workstations, cytotoxic cabinets, hospital pharmacy isolators, and PCR cabinets and instrumentation. With the most extensive product line in the industry, Esco has passed more tests, in more languages, for more certifications, throughout more countries than any biosafety cabinet manufacturer in the world. Esco remains dedicated to delivering innovative solutions for the clinical, life science, research and industrial laboratory community. [www.escoglobal.com](http://www.escoglobal.com).*

Microbiological Safety Cabinets • Animal Containment Workstations • Fume Hoods • Clean Benches



WORLD CLASS. WORLDWIDE.

Esco Technologies, Inc. • 2940 Turnpike Drive, Units 15-16 • Hatboro, PA 19040 USA  
Toll-Free USA and Canada 877-479-ESCO • Tel +1 215 441 9661 • Fax +1 215 441 9660  
[us.escoglobal.com](http://us.escoglobal.com) • [usa@escoglobal.com](mailto:usa@escoglobal.com)

Esco Micro Pte. Ltd. • 21 Changi South Street 1 • Singapore 486 777  
Tel +65 6542 0833 • Fax +65 6542 6920 • [mail@escoglobal.com](mailto:mail@escoglobal.com)  
[www.escoglobal.com](http://www.escoglobal.com)

Esco Global Offices | Singapore | Philadelphia, USA | Leiden, The Netherlands | Salisbury, UK  
Kuala Lumpur, Malaysia | Beijing, Shanghai & Guangzhou, China | Mumbai, India | Manama, Bahrain



©2008 Esco Micro Pte. Ltd. Specifications Subject to Change. OW84968/051448\_V2\_L3K\_08/08