



## Centrifuge 5424

**eppendorf**

## Centrifuge 5424

Inhaltsverzeichnis .....	5
Instruction Manual .....	27
Notice abrégée .....	49
Istruzioni in breve .....	58
Instrucciones breves .....	67
Beknopte handleiding .....	76
Kort vejledning .....	85
Kort handledning .....	94
Pikaohje .....	103
Manual abreviado .....	111
Συνοπτικές οδηγίες .....	120

No part of this publication may be reproduced without the prior permission of the copyright owner.

Copyright© 2005 Eppendorf AG, Hamburg

# Centrifuge 5424

Figure 1 / Abbildung 1

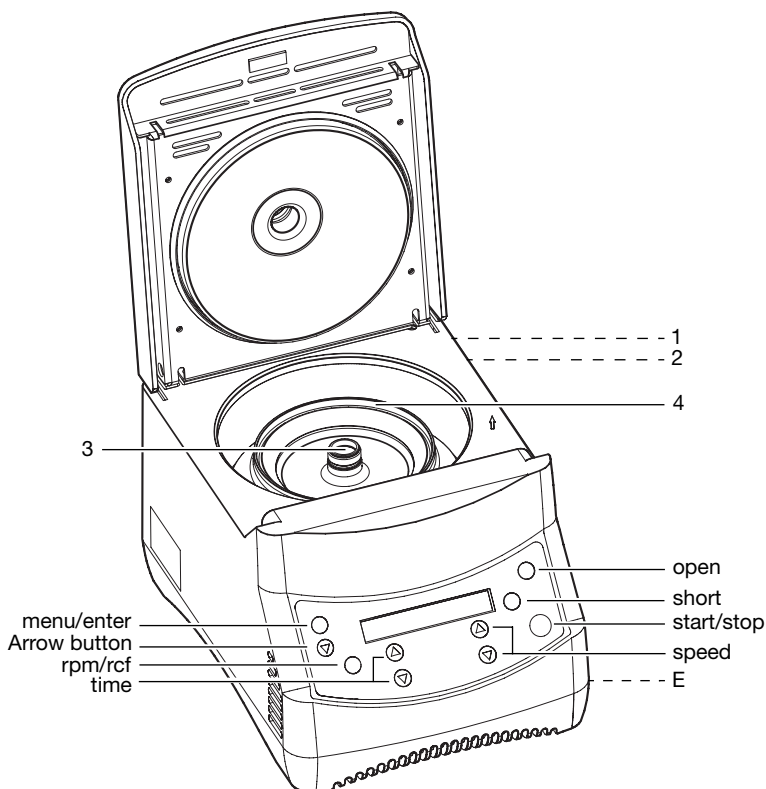

<b>menu/enter</b>	menu/enter button	menu/enter-Taste
<b>Arrow button</b>	Arrow button	Pfeiltaste
<b>rpm/rcf</b>	rpm/rcf button	rpm/rcf-Taste
<b>time</b>	Time arrow buttons	Zeitwahl-Pfeiltasten
<b>speed</b>	Speed arrow buttons	Geschwindigkeits-Pfeiltasten
<b>open</b>	Lid release button	Deckelentriegelungs-Taste
<b>short</b>	Short run button	Kurzzeitlauf-Taste
<b>start/stop</b>	Start/stop button	Start/Stop-Taste
<b>1</b>	Power plug	Netzstecker
<b>2</b>	Power switch	Netzschalter
<b>3</b>	Rotor nut	Rotormutter
<b>4</b>	Rotor	Rotor
<b>E</b>	Emergency lid release	Notentriegelung

# Centrifuge 5424

Figure 2 / Abbildung 2

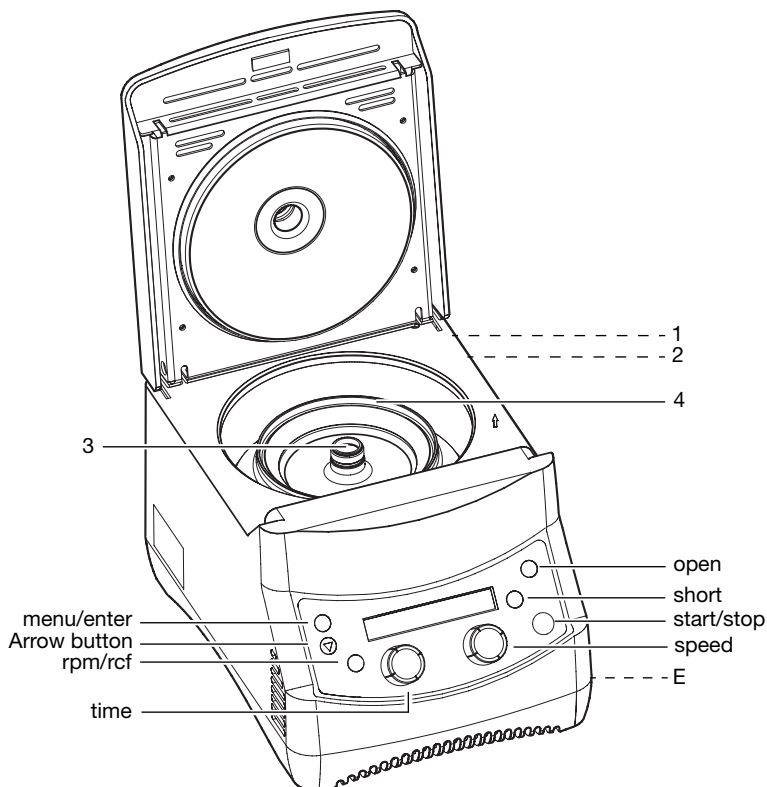

<b>menu/enter</b>	menu/enter button	menu/enter-Taste
<b>Arrow button</b>	Arrow button	Pfeiltaste
<b>rpm/rcf</b>	rpm/rcf button	rpm/rcf-Taste
<b>time</b>	Time knob	Zeitwahl-Drehknopf
<b>speed</b>	Speed selector knob	Geschwindigkeits-Drehknopf
<b>open</b>	Lid release button	Deckelentriegelungs-Taste
<b>short</b>	Short run button	Kurzzeitlauf-Taste
<b>start/stop</b>	Start/stop button	Start/Stop-Taste
<b>1</b>	Power plug	Netzstecker
<b>2</b>	Power switch	Netzschalter
<b>3</b>	Rotor nut	Rotormutter
<b>4</b>	Rotor	Rotor
<b>E</b>	Emergency lid release	Notentriegelung

# Table of contents

<b>1</b>	<b>Introduction .....</b>	<b>28</b>
1.1	Delivery package .....	28
1.2	Installing the device .....	28
<b>2</b>	<b>Safety precautions and applicational limitations.....</b>	<b>30</b>
<b>3</b>	<b>Operation .....</b>	<b>33</b>
3.1	Functional and operator control elements.....	33
3.2	Menu structure.....	34
3.3	Fitting and removing the rotors .....	34
3.4	Loading the rotors .....	34
3.5	Rotors .....	34
3.6	Centrifugation with timer setting.....	35
3.7	Adjusting centrifuging parameters during centrifugation .....	35
3.8	Short spin centrifugation .....	36
3.9	Continuous operation .....	36
3.10	rcf display and calculation .....	37
3.11	Setting startup and braking ramp.....	38
3.12	Run start .....	38
3.13	Permanent setting of parameters .....	39
3.14	Activating and deactivating the loudspeaker .....	39
3.15	Volume control.....	40
3.16	Standby mode .....	40
3.17	Opening the centrifuge in case of power failure.....	41
3.18	Fuses .....	41
<b>4</b>	<b>Maintenance and cleaning .....</b>	<b>42</b>
4.1	Device .....	42
4.2	Rotors .....	42
4.3	Glass breakage .....	43
4.4	Returning devices .....	43
<b>5</b>	<b>Troubleshooting .....</b>	<b>44</b>
<b>6</b>	<b>Technical data.....</b>	<b>45</b>
<b>7</b>	<b>Ordering information .....</b>	<b>46</b>

# 1 Introduction

The Centrifuge 5424 is a non-refrigerated bench-top centrifuge for use by trained professionals in research, routine and training laboratory work in the biosciences, medicine, clinical diagnostics, industry and the chemistry field. The various fixed-angle rotors and adapters enable a large number of tubes like micro test tubes, PCR strips, Microtainers® and Spin Columns to be used. In the context of *in vitro* diagnostics, the Centrifuge 5424 is designed among other things for chromosome analysis of human cells by the FISH technique (Kievits et al. 1990).

**Before using the centrifuge 5424 for the first time, please read the manual. The latest version of the manual and the safety instructions in your language can be found on the Internet at [www.eppendorf.com](http://www.eppendorf.com).**



You will see this symbol on your centrifuge and at a number of points throughout this manual. The texts it highlights are relevant to safety. Use the centrifuge only when you have read these safety instructions.

## 1.1 Delivery package

- 1 Centrifuge 5424
- 1 Rotor FA-45-24-11 incl. rotor lid (only for order no. 5424 000.410, 5424 000.010, 5424 000.428, 5424 000.029, 022620428, 022620461, 022620401 and 022620444)
- 1 power cable
- 1 manual
- 1 rotor key
- 1 Captain Eppi rotor key holder
- 1 set of fuses

## 1.2 Installing the device



- To disconnect the power supply of the centrifuge from the power supply in the event of a fault, an emergency switch must be provided away from the centrifuge, preferably outside the room in which the centrifuge is located or next to the exit from this room.
- Remove the transport safety device and keep it together with the centrifuge packaging for possible use if the device is subsequently moved.
- Place the centrifuge on a solid, flat, non-resonant lab bench. Check beforehand whether the lab bench is specified for the weight of the centrifuge.
- The surrounding area must be well-ventilated and protected against direct sunlight. To ensure that ventilation of the device is not impaired, a minimum fundamental clearance of at least 30 cm to the side and at least 15 cm to the back wall must be maintained.
- During centrifugation, according to the recommendations set out in EN 61010-2-020, a safety clearance of 30 cm must be maintained around the centrifuge within which there are no objects which may be destroyed and so cause further damage.
- Please ascertain that the power supply and the power frequency are compatible with the information given on the device ID plate.

# 1 Introduction

- Now connect the centrifuge to the power supply and switch it on at the main power switch (see inside cover page). The centrifuge is now ready for operation and the display is active.
- **Before starting for the first time, check whether the rotor and the rotor lid are tightened in accordance with specification.** To tighten the rotor, place the rotor key supplied on the rotor nut and turn it clockwise until the rotor nut is firmly tightened up. The rotor lid is then tightened up.

## 2 Safety precautions and applicational limitations



For your personal safety, please be sure to comply with the following regulations unconditionally.

- The centrifuge 5424 must only be used for the specified applications (see Section 1, "Introduction"). It must not be operated in explosive atmospheres. Explosive, radioactive or highly reactive substances must not be centrifuged.
- When being moved from the cool room to a normal lab environment, the centrifuge must either run for half an hour in the cool room first to warm up, or it must warm up for at least 3 hours in the lab before being connected to the power supply system, in order to prevent damage from condensation.
- The centrifuge must not be moved or knocked while in operation.
- Centrifuges which have not been properly installed or repaired may not be operated. Repairs may only be carried out by Service personnel authorized by Eppendorf. Use only original Eppendorf spare parts and rotors.
- When handling toxic liquids or pathogenic microorganisms of risk group II (see World Health Organization: Laboratory Biosafety Manual) comply with the relevant national regulations. Bioseals are a component of biosafety systems which are not capable, in isolation, of ensuring that people and the environment are protected when pathogenic microorganisms are being handled. When working with pathogenic microorganisms of a higher risk group, more than one aerosol-tight bioseal must be provided for. If the named liquids are spilled in the rotor or rotor chamber, the centrifuge must be thoroughly and professionally cleaned. Before using any cleaning or decontamination method other than that set out in Section 4, "Maintenance and cleaning", please consult Eppendorf to ensure the intended method will not damage the device.
- **Rotors and rotor lids must always be properly secured. The centrifuge may only be operated with the rotor and rotor lid firmly tightened. To do this, before centrifugation, place the rotor key supplied for tightening up the rotor on the rotor nut and turn it clockwise until the rotor nut is firmly tightened up. The rotor lid is then screwed on tightly** (see Section 3.5 "Rotors" with regard to exceptions for rotors FA-45-24-11 and FA-45-24-11-Special for centrifuging micro test tubes with closed tube lids).  
If unusual noises occur when the centrifuge starts, the rotor or the rotor lid are not properly secure. In this case, stop centrifugation immediately using **start/stop**.
- The rotor may only be loaded symmetrically. Opposing vessels should be of the same type and be filled equally. On each rotor you will find information about maximum load (adapter, tube and contents) per bore - this limit may not be exceeded.
- Rotors showing clear signs of corrosion or mechanical damage must not be used. Check the accessories regularly.

## 2 Safety precautions and applicational limitations

- Rotors are high-grade components which have to withstand extreme stresses and strains. Aluminum rotors are surface-treated to provide them with a high level of protection from corrosion by the most common laboratory chemicals, though this protection is not unlimited. Avoid damage from the use of aggressive chemicals such as strong and weak alkalis, strong acids, solutions of mercury, copper and other heavy metal ions, chlorinated hydrocarbons, concentrated salt solutions and phenol. If the rotor is contaminated by aggressive substances, clean it immediately with a neutral agent (e.g. Extran® neutral, RBS® neutral or Teepol® 610 S). This applies to the rotor bores in particular.  
Rotors labeled "coated" are particularly resistant to chemicals. However, even on these rotors, this does not replace regular cleaning as described in Section 4 "Maintenance and cleaning".  
Protect the rotors from mechanical damage. Even minor scratches or cracks can result in serious internal material damage.
- The material being centrifuged may not exceed a density of 1.2 g/ml at maximum speed.
- If the rotor is run for a lengthy period or more often with short centrifugation runs, the sample tubes will become hot.
- Keep within the load limits specified for the tubes by the tube manufacturer. Tubes may only be centrifuged at the preselected g-force (rcf) if they are approved for this application by the manufacturer.
- Before centrifugation, all the tubes should be subjected to a visual inspection for material damage. Damaged tubes must not be centrifuged, as if tubes break, there may be further damage to the centrifuge and its accessories in addition to loss of the sample.
- **Tube lids must be sealed down tight before centrifuging.** The lids of tubes which are not sealed may rip off during centrifugation and damage the rotor lid and the centrifuge.
- When using organic solvents (e.g. phenol, chloroform), the durability of plastic tubes may be impaired with the result that tubes may break during centrifugation.
- When closing the centrifuge lid, do not place your fingers between the lid and the centrifuge, otherwise they may be trapped.
- The transparent rotor covers made from polypropylene have a maximum useful life of 3 years. The date of manufacture is impressed on them in the form of a watch .  
**Rotors and rotor covers which have been damaged chemically or mechanically or which have passed their maximum useful life must no longer be used.**

### Declaration concerning the ATEX directive (94/9/EC)

The present design and ambient conditions inside Eppendorf centrifuges mean that they are not suitable for use in a potentially explosive atmosphere. The centrifuges must therefore only be used in a safe environment such as the open environment of a ventilated laboratory or a fully-extracted fume hood. The use of substances which may contribute to a potentially explosive atmosphere is not permitted. The final decision on the risks in connection with the use of such substances is the responsibility of the user of the centrifuge.

## 2 Safety precautions and applicational limitations

### Transfer

If the device is passed on to someone else, please include the instruction manual.

### Disposal

In case the product is to be disposed of, the relevant legal regulations are to be observed.

### Information on the disposal of electrical and electronic devices in the European Community

The disposal of electrical devices is regulated within the European Community by national regulations based on EU Directive 2002/96/EC on waste electrical and electronic equipment (WEEE).

According to these regulations, any devices supplied after 13.08.05 in the business-to-business sphere, to which this product is assigned, may no longer be disposed of in municipal or domestic waste. They are marked with the following symbol to indicate this.



As disposal regulations within the EU may vary from country to country, please contact your supplier if necessary.



## 3 Operation

### 3.1 Functional and operator control elements

See the frontal view (Figure 1 / 2) on the first inside cover page of this manual.

<b>menu/enter</b>	Menu/enter button	see Section 3.8
	Arrow button	see Section 3.8
<b>rpm/rcf</b>	rpm/rcf button	see Section 3.10
<b>time</b>	Time knob/arrow buttons	see Sections 3.6, 3.7 and 3.9
<b>speed</b>	Speed selector knob/arrow buttons	see Sections 3.6 and 3.7
<b>open</b>	Lid release button	see Section 3.6
<b>short</b>	Short run button	see Section 3.8
<b>start/stop</b>	Start/stop button	see Section 3.6
<b>1</b>	Power plug	see Section 3.6
<b>2</b>	Power switch	see Section 3.6
<b>3</b>	Rotor nut	see Section 3.3
<b>4</b>	Rotor	see Sections 3.3 to 3.5
<b>E</b>	Emergency lid release	see Section 3.17

### 3.2 Menu structure

In the menu you can

- adjust the startup and braking ramp,
- activate and deactivate the loudspeaker,
- adjust run start,
- vary the speed of short run centrifugation,
- switch standby mode on and off,
- control volume and
- set permanent centrifugation parameters.

**menu/enter** activates the menu and confirms a selected menu item or adjusted setting.



the arrow button selects a menu item

The menu consists of two levels, **M1** and **M2**. In the first menu level, you can select between the various menu items. The symbols for the functions light up. In addition, the symbol for each menu item selected flashes in the activated setting. In the second menu level, the setting for the selected function can be amended. The relevant symbol always appears when the settings are selected.

The last inside cover page shows the menu structure with reference to the relevant sections of this manual.

## 3 Operation

### 3.3 Fitting and removing the rotors



Fit the rotor onto the motor shaft and tighten the rotor nut firmly by turning it clockwise using the appropriate rotor key provided. Before each start, check that the rotor is firmly tightened.

To release the rotor, turn the rotor nut anticlockwise using the rotor key.

Under no circumstances centrifuge with rotors which already have obvious traces of corrosion or mechanical damage (see Section 2 "Safety precautions and applicational limitations").

### 3.4 Loading the rotors



The rotors must only be loaded symmetrically. The adapters must be loaded only with the specified tubes. Minimize differences in weight between the filled sample tubes - taring with a scale is recommended. This will reduce wear on the drive and cut running noise.

The maximum load per bore is indicated on each rotor.

### 3.5 Rotors

A maximum of 24 x 1.5/2.0 ml micro test tubes can be centrifuged in rotors **FA-45-24-11** and **FA-45-24-11-Special**. With the appropriate adapters, it is also possible to load it with 0.2 ml PCR tubes, 0.4 ml micro test tubes, 0.5 ml micro test tubes and 0.6 ml Microtainers<sup>®</sup>. It is also possible to load the rotor with 24 Spin Columns. However, the rotor F-45-18-11-Kit is recommended for centrifuging Spin Columns. The maximum speed of rotors **FA-45-24-11** and **FA-45-24-11-Special** is 14,680 rpm (120 V: 15,000 rpm) and the maximum g-force (rcf) 20,238 x g (120 V: 21,130 x g). The maximum load (adapter, tube and contents) per bore for the rotors is **3.75 g**.



Rotors **FA-45-24-11** and **FA-45-24-11-Special** can be operated both with and without a rotor lid. Without a rotor lid, the rotors are not aerosol-tight and are slightly noisier. Particular attention should be paid to the fact that tube lids are closed in accordance with specification before centrifugation. Aerosol-tight centrifugation can only be carried out with the rotor lid in place. **Spin Columns must always be centrifuged with the rotor lid**. The rotor lid is not required during standard operation.

With the rotor **F-45-18-11-Kit**, up to 18 Spin Columns can be centrifuged at a maximum of 14,680 rpm (120 V: 15,000 rpm) or 17,347 x g (120 V: 18,111 x g). This rotor is characterized by a particularly high edge so that all standard Spin Columns fit under the rotor lid. But it is also possible to load the rotor with 1.5/2.0 ml micro test tubes, and using the appropriate adapters, with 0.2 ml PCR tubes, 0.4 ml micro test tubes, 0.5 ml micro test tubes and 0.6 ml Microtainers<sup>®</sup>. The maximum load (adapter, tube and contents) per bore for this rotor is **3.75 g**.



Rotor **F-45-18-11-Kit** may only be centrifuged with the rotor lid tightened in accordance with specification.

## 3 Operation

With rotor **F-45-32-5-PCR**, up to 32 PCR tubes (0.2 ml) or four 5x or 8x rows of 0.2 ml PCR tubes can be centrifuged at maximum 14,680 rpm (120 V: 15,000 rpm) or 17,829 x g (120 V: 18,615 x g). Maximum load (tubes and contents) per 8x row with this rotor is **3.5 g**.



Rotor **F-45-32-5-PCR** may only be centrifuged with the rotor lid tightened in accordance with specification.

When loading rotors, make sure that the micro test tubes are inserted in the rotor bores opposite one another in pairs. To ensure that the rotor is symmetrically loaded, opposing tubes must contain the same filling volume.

### 3.6 Centrifugation with timer setting

Switch on the centrifuge with the power switch if necessary and open the lid using the **open** button. The specified values of the last run are displayed. Load the rotor symmetrically, fit the rotor lid and close the centrifuge lid.

**time** adjusts the run time up to 10 min. in 0.5 min. increments, then in 1 min. increments up to 09:59 h.

**speed** adjusts the speed in increments of 50 rpm or the g-force (rcf) in increments of 50 x g.

**start/stop** starts centrifugation. The symbol  flashes while the rotor is running.

During centrifugation, the remaining run time is displayed in minutes. The last minute is counted down in seconds. In addition, the speed of the rotor/relevant g-force (rcf) is displayed. The timer setting, speed and rpm/rcf display can be adjusted during centrifugation. The menu, the **open** and the **short** buttons are blocked during centrifugation.

**start/stop** if the button is pressed again, centrifugation is stopped before expiry of the set run time.

After expiry of the set run time, the centrifuge will otherwise stop automatically. During braking, the timer flashes and shows the spin time which has elapsed. When the rotor has come to a standstill, a signal tone is heard and the centrifuge lid opens automatically. The display then shows the symbol .

### 3.7 Adjusting centrifuging parameters during centrifugation

The timer setting and rotation speed can be changed during centrifugation using the two knobs or the arrow buttons. If these parameters are adjusted, the display begins flashing. The new centrifuging parameters are accepted after a short time.

The time which has elapsed up to this point is offset against the new actual value. In order that centrifugation cannot be stopped by changing the timer setting, the shortest time which can be set is the time which has already elapsed plus 2 minutes. Parameters cannot be adjusted during the braking process.

## 3 Operation

### 3.8 Short spin centrifugation

Switch on the centrifuge with the power switch if necessary and open the lid using the **open** button. The specified values of the last run are displayed. Load the rotor symmetrically, fit the rotor lid and close the centrifuge lid.

**short** starts a short run at the specified speed. The **short** button must be kept depressed throughout the entire short run. The symbol  flashes while the rotor is running. Time is counted upwards in seconds. Centrifugation is stopped by releasing the **short** button during the braking process, centrifugation can be re-started twice by pressing the **short** button again.

The timer flashes and shows the spin time which has elapsed during braking. When the rotor has come to a standstill, the centrifuge lid opens automatically. The display then shows the symbol .

During a short run, all other buttons and knobs are blocked.

Specified speed is set via the menu:

**menu/enter** activates the menu.



select the item **SHORT** and confirm with

**menu/enter**.



in the second menu level, select the item **MAX** in order to centrifuge at maximum speed/g-force. To perform short-run centrifugation at the currently-set speed/g-force, select the item **SET** with the arrow button.

**menu/enter** confirms the set speed and you automatically return to the item **BACK** in the first menu level. Press the key again to exit the menu.

If the specified speed is not to be changed after all, it is possible to exit the second menu level by selecting the **BACK** menu item and then confirming with the **menu/enter** button.

### 3.9 Continuous operation

Switch on the centrifuge with the power switch if necessary and open the lid using the **open** button. The specified values of the last run are displayed. Load the rotor symmetrically, fit the rotor lid and close the centrifuge lid.

**time** the continuous function is set using the **time** selection knob/arrow buttons to above 09:59 h or below 30 sec. The timer shows "oo" to indicate continuous running. Time is counted upwards in 30-second increments.

**speed** adjusts the speed in increments of 50 rpm or the g-force (rcf) in increments of 50 x g.

**start/stop** starts centrifugation. The symbol  flashes while the rotor is running.

**start/stop** if the button is pressed again, centrifugation will stop.

During braking, the timer flashes and shows the spin time which has elapsed. When the rotor has come to a standstill, a signal tone is heard and the centrifuge lid opens automatically. The display then shows the symbol .

## 3 Operation

### 3.10 rcf display and calculation

**rpm/rcf** Pressing the button toggles the display from rpm (1/min) to rcf and vice versa.

Please note that the g-force (rcf) shown when toggling the display is standardized to rotor FA-45-24-11/ FA-45-24-11-Special without adapter. At the maximum speed in each case you can achieve the following maximum g-force (rcf) in the various rotors with the different adapters:

Rotor	Adapter	Max. centrifugal radius $r_{\max}$ [cm]	Max. g-force (rcf) (230 V / 100 V)	Max. g-force (rcf) (120V)
<b>FA-45-24-11, FA-45-24-11-Special</b>	without adapter	8,4	20.238	21.130
	0.2 ml	6,3	15.179	15.848
	0.4 ml	8,4	20.238	21.130
	0.5 ml	7,3	17.588	18.363
	0.6 ml	8,4	20.238	21.130
<b>F-45-18-11-Kit</b>	without adapter	7,2	17.347	18.111
	0.2 ml	5,1	12.288	12.829
	0.4 ml	7,2	17.347	18.111
	0.5 ml	6,1	14.697	15.345
	0.6 ml	7,2	17.347	18.111
<b>F-45-32-5-PCR</b>		7,4	17.829	18.615

To calculate the g-force (rcf) for a specific adapter you can apply the following formula according to DIN 58 970:

$$\text{rcf} = 1.118 \cdot 10^{-5} \cdot n^2 \cdot r_{\max}$$

n: speed in rpm

$r_{\max}$ : max. centrifugal radius in cm

Example: in rotor FA-45-24-11, the 0.5 ml adapter has a maximum radius of 7.3 cm. At 7,000 rpm, a maximum g-force (rcf) of 4,000 x g is achieved.

## 3 Operation

### 3.11 Setting startup and braking ramp

When setting the startup and braking ramp, you can select between two levels. Selection is made using the menu:

**menu/enter** activates the menu.



select the item **SOFT** and confirm with

**menu/enter**.



in the second menu level, select the item **ON** for the rotor to start up and brake more slowly and the item **OFF** for it to start up and brake more quickly.

**menu/enter** confirms the amended startup and braking ramp and you automatically return to the item **BACK** in the first menu level. Press the key again to exit the menu.

If the startup and braking ramp is not to be changed after all, it is possible to exit the second menu level by selecting the **BACK** menu item and then confirming with the **menu/enter** button.

If the slower startup and braking ramp is switched on, the symbol  appears in the display.

### 3.12 Run start

For centrifugation, time can be counted either immediately from the start or not until attainment of the preset speed or g-force (rcf). This is specified via the menu:

**menu/enter** activates the menu.



select the item **ATSET** and confirm with



**menu/enter**.



In the second menu level select the item **ON** for time to be counted only once the set speed/g-force (rcf) has been reached. Select the item **OFF** if time is to be counted from the start of centrifugation.

**menu/enter** confirms the selected run start and you automatically return to the item **BACK** in the first menu level. Press the key again to exit the menu.

If the setting for run start is not to be changed after all, it is possible to exit the second menu level by selecting the **BACK** menu item and then confirming with the **menu/enter** button.

The selected setting is shown in the display. If time is counted from the start, the symbol  appears. If time is only counted from when the specified speed/g-force (rcf) is reached, this is symbolized by .

## 3 Operation

### 3.13 Permanent setting of parameters

The selected centrifugation parameters can be permanently set via the menu so that neither time or rotation speed/g-force (rcf) can be altered using the relevant knobs/arrow buttons:

**menu/enter** activates the menu.



select the item **LOCK** and confirm with



**menu/enter**.



In the second menu level, select the item **ON** if centrifugation parameters are to be made permanent. To enable centrifugation parameters to be set freely, select the item **OFF** using the arrow button.

**menu/enter** confirms the permanent setting of parameters and you automatically return to the item **BACK** in the first menu level. Press the key again to exit the menu.

If the permanent setting of parameters is not to be changed after all, it is possible to exit the second menu level by selecting the **BACK** menu item and then confirming with the **menu/enter** button.

The selected setting is shown in the display. Once the centrifugation parameters are locked, the display shows the symbol of a . If the set parameters can be adjusted, this is symbolized by an .

If the parameters have been permanently set and these are to be changed using the knobs/arrow buttons, **SAFE** appears in the display.

### 3.14 Activating and deactivating the loudspeaker

The loudspeaker is activated and deactivated via the menu:

**menu/enter** activates the menu.



select the item **ALARM** and confirm with

**menu/enter**.



In the second menu level, select the item **ON** to activate the loudspeaker. The loudspeaker can be deactivated via the **OFF** item.

**menu/enter** confirms that the loudspeaker has been activated/deactivated and you automatically return to the item **BACK** in the first menu level. Press the key again to exit the menu.

If the setting for the loudspeaker is not to be changed after all, it is possible to exit the second menu level by selecting the **BACK** menu item and then confirming with the **menu/enter** button.

When the loudspeaker is activated, the symbol  appears in the display.

## 3 Operation

### 3.15 Volume control

The volume of the loudspeaker is controlled in the menu. The loudspeaker needs to be activated for you to hear the change in volume (see Section 3.14 "Activating and deactivating the loudspeaker"):

**menu/enter** activates the menu.



select the item **VOL** and confirm with

**menu/enter**.



In the second menu level, select the item **VOL1**. A beep is heard. To increase the volume of this sound further, use the arrow button to select the other items **VOL2** to **VOL5**. For every change, a signal at the new volume is heard, becoming louder each time.

**menu/enter** confirms the selected volume of the loudspeaker and you automatically return to the item **BACK** in the first menu level. Press the key again to exit the menu.

If the volume is not to be changed after all, it is possible to exit the second menu level by selecting the **BACK** menu item and then confirming with the **menu/enter** button.

### 3.16 Standby mode

If the centrifuge has not been used for 15 min., it switches to standby mode. The "EP" logo then appears in the display. When a button (or knob) is used or the centrifuge lid is closed, the centrifuge is reactivated and ready for operation.

Standby mode can be switched on and off via the menu:

**menu/enter** activates the menu.



select the item **SLEEP** and confirm with

**menu/enter**.



In the second menu level, select the item **ON** to switch on Standby mode. Standby mode can be switched off via the **OFF** item.

**menu/enter** confirms that Standby mode has been switched on/off and you automatically return to the item **BACK** in the first menu level. Press the key again to exit the menu.

If standby mode is not to be changed after all, it is possible to exit the second menu level by selecting the **BACK** menu item and then confirming with the **menu/enter** button.

## 3 Operation

### 3.17 Opening the centrifuge in case of power failure



If the lid release does not function following a power failure, the emergency lid release can be operated by hand.

To do so, first unplug the power plug. Before activating the emergency release, also ensure that the rotor has come to a standstill. Check by looking through the window in the centrifuge lid. It can take up to 6 minutes for the rotor to come to a standstill. The emergency release is located on the right-hand side of the centrifuge (see “E” in Figure 1 / 2, first inside cover page).

After a visual check that the rotor has come to a standstill, first remove the plastic cap. The rotor key supplied then has to be inserted in the nut underneath the cap and turned anticlockwise. This releases the lid and allows it to be opened.

The rotor key **must** then be removed immediately and the plastic cap put back on.

### 3.18 Device fuses

The fuse box is located under the power plug. To replace the fuses, unplug the power plug and pull the fuse box out towards the rear. The two fuses can then be replaced (see Ordering information).

## 4 Maintenance and cleaning

### 4.1 Device

The outer surfaces of the centrifuge and the rotor chamber should be cleaned regularly with a neutral agent (e.g. Extran<sup>®</sup> neutral, RBS<sup>®</sup> neutral or Teepol<sup>®</sup> 610 S). This is for hygiene purposes and to prevent adhering impurities causing corrosion.

If material hazardous to health or aggressive material contaminate the device, the owner is responsible for appropriate cleaning and decontamination.

Before cleaning, unplug the power plug with the lid open, unscrew the rotor using the rotor key supplied and clean it separately. Use only neutral agents for cleaning (e.g. Extran<sup>®</sup> neutral, RBS<sup>®</sup> neutral, Teepol<sup>®</sup> 610 S). Bacilloi<sup>®</sup> AF, Meliseptol<sup>®</sup> und Perform<sup>®</sup> are recommended for cleaning and disinfecting the outer surface of the centrifuge and the rotor chamber. Do not allow any liquid to get into the gap at the motor shaft outlet. For this reason, the rotor chamber should be cleaned only with a damp cloth.

The outer surface of the centrifuge and the rotor chamber have been tested for resistance to the cleaning agents and disinfectants mentioned. However, this does not guarantee that the device is disinfected following application of one of the methods mentioned. You should also consult your laboratory safety officer with regard to a suitable method of cleaning and disinfecting.

Before any cleaning or disinfecting method other than that recommended by the manufacturer is used, please check with Eppendorf that the intended method will not damage the device or its accessories. In order to ensure long-term, reliable work with your centrifuge, please note that aggressive chemicals may damage the rotor and the chamber. Check your device once a month for corrosion and damage.

The rubber seals in the rotor chamber should be rinsed off thoroughly with water and lubricated with glycerin or talc after every clean to prevent them becoming brittle.

### 4.2 Rotors

Rotors need cleaning regularly to prevent residues of the material being centrifuged from changing their properties. Check the rotors for residues and corrosion at least once a month. This applies to the rotor bores in particular. Please look after your rotor regularly; this will protect it and increase its service life.

For thorough cleaning, the rotor is unscrewed using the rotor key supplied and cleaned using a neutral agent (e.g. Extran<sup>®</sup> neutral, RBS<sup>®</sup> neutral, Teepol<sup>®</sup> 610 S). Bacilloi<sup>®</sup> AF, Meliseptol<sup>®</sup> und Perform<sup>®</sup> are recommended for cleaning and disinfecting the rotor and the rotor bores. The rotor bores are also brushed out with a bottle brush. The rotor and bores are then rinsed out thoroughly and placed on a cloth with the bores facing downwards to dry. The rotor is then put back in and the rotor nut tightened up.

The rotors have been tested for resistance to the cleaning agents and disinfectants mentioned. However, this does not guarantee that the device is disinfected following application of one of the methods mentioned. You should also consult your laboratory safety officer with regard to a suitable method of cleaning and disinfecting. However, before any cleaning or disinfecting method other than that recommended by the manufacturer is used, please check with Eppendorf that the intended method will not damage the rotors or their accessories. In order to ensure long-term, reliable work with your centrifuge, please note that aggressive chemicals may damage the rotor.

## 4 Maintenance and cleaning

All the rotors, rotor lids and adapters can be autoclaved (121 °C, 20 min.). The lids of aerosol-tight rotors FA-45-24-11 and FA-45-24-11-Special should be replaced after no more than 10 autoclaving operations.

On the aerosol-tight rotors, the rotor lids should be replaced if the sealing rings on the lid thread and in the lid groove become worn. Regular care of the sealing rings is required to protect the rotors. Check that the seals are undamaged before use.

Aerosol-tight rotors may not be stored with lids done up tightly!

### 4.3 Glass breakage

When centrifuging glass tubes, be aware that as speed/rcf increases, so does the risk of glass breaking. Please observe manufacturers' information about maximum loading of centrifuge tubes.

In case of glass breakage, carefully remove all splinters and all ground glass from the rotor, the adapters and the rotor chamber. You may need to replace adapters in order to prevent further damage.

Otherwise fine glass splinters will scratch the surface of the rotors, reducing their resistance to chemicals. Air vortices will result in very fine black abraded metal in the rotor chamber; in addition to damaging the rotor chamber, rotor and adapters, this material will also cause samples to become contaminated.

Check the rotor bores regularly for residues or damage.

### 4.4 Returning devices

When returning centrifuges, ensure that these devices are fully decontaminated and do not present any kind of health risk to our service staff.

For further information and a blank of the decontamination confirmation, please visit [www.eppendorf.com](http://www.eppendorf.com). Do also consult your laboratory safety officer about a suitable decontamination method.

Please fill in the decontamination confirmation and enclose it with the device if it is to be returned to Eppendorf.

## 5 Troubleshooting guide

If the suggested rectification measures repeatedly fail, contact Eppendorf.

Error / Display	Cause	Remedy
No display	No power	Check power connection
	Power failure	Check power fuses of device and laboratory
Lid cannot be opened	Power failure	See above, activate emergency lid release
	Rotor still running	Wait for rotor to stop
Centrifuge will not start	Lid not closed	Press lid shut
Centrifuge shakes when starting up	Rotor unevenly loaded	Stop centrifugation and load evenly
Centrifuge brakes during a short run although the <b>short</b> button is still depressed	Button was released briefly more than 2x (drive protection function)	Do not release button during a short run
LID ERROR	Lid cannot be locked	Close lid again and start
	Lid cannot be unlocked	Switch device off and back on, press the <b>open</b> button, if error recurs: switch off device, activate emergency lid release, if error recurs => Service
	Lid cannot be unlocked during a run	Wait for centrifuge to come to a standstill, repeat run, if error recurs => Service
INT	Power interruption during a run	Check power plug
NO RPM	Error in speed measuring system	Leave device switched on until the error message disappears (10 s or 6 min.), repeat run, if error recurs => Service
Err 6	Drive error	Repeat run, if error recurs => Service
Err 7	Overspeed or major control deviation	Check rotor properly tightened, repeat run
Err 8	Rotor loose, drive error	Tighten up rotor, repeat run, if error recurs => Service
Err 11	Power interruption during a run	Check power plug, repeat run
Err 9, 10, 12 - 17	Electronics error	Repeat run, if error recurs => Service

## 6 Technical data

Mains power connection:	230 V / 50 – 60 Hz 120 V / 50 - 60 Hz 100 V / 50 - 60 Hz
Power output	250 W
Max. speed	100 to 14,680 rpm (230 V / 100 V) 100 to 15,000 rpm (120 V)
Max. relative centrifugal force (rcf)	20,238 x g (230 V / 100 V) 21,130 x g (120 V)
Max. load	24 x 2.0 ml micro test tubes
Max. kinetic energy	7500 Nm
Permissible density of material to be centrifuged	1.2 g/ml
Ambient temperature	2 - 40 °C
Relative humidity	10 - 75 %
Setup height	max. 2000 m above NSL
Dimensions	Width: 236 mm Depth: 320 mm Height: 227 mm
Weight excluding rotor:	13.4 kg
Startup time (230 V)	15 s
Deceleration time (230 V)	16 s
Startup time (120 V)	15 s
Deceleration time (120 V)	18 s
Startup time (100 V)	20 s
Deceleration time (100 V)	16 s
Fuses	2.5 AT (230 V) 5.0 AT (120 V / 100 V)
Noise level	< 56 dB (A)
Overvoltage category	II
Degree of contamination:	2

Technical specifications subject to change!

## 7 Ordering information

7

Ordering information

	Order no. International	Order no. North America
<b>Centrifuge 5424</b> with knobs, without rotor 230 V / 50 - 60 Hz	5424 000.614	022620436
<b>Centrifuge 5424</b> with keypad, without rotor 230 V / 50 - 60 Hz	5424 000.215	022620452
<b>Centrifuge 5424</b> with knobs, with rotor FA-45-24-11 incl. rotor lid, 230 V / 50 - 60 Hz	5424 000.410	022620428
<b>Centrifuge 5424</b> with keypad, with rotor FA-45-24-11 incl. rotor lid, 230 V / 50 - 60 Hz	5424 000.010	022620461
<b>Centrifuge 5424</b> with knobs, without rotor 120 V / 50 - 60 Hz	5424 000.622	022620487
<b>Centrifuge 5424</b> with keypad, without rotor 120 V / 50 - 60 Hz	5424 000.223	022620498
<b>Centrifuge 5424</b> with knobs, with rotor FA-45-24-11 incl. rotor lid, 120 V / 50 - 60 Hz	5424 000.428	022620401
<b>Centrifuge 5424</b> with keypad, with rotor FA-45-24-11 incl. rotor lid, 120 V / 50 - 60 Hz	5424 000.029	022620444
<b>Fixed-angle rotors and rotor lids</b>		
Fixed-angle rotor FA-45-24-11 with rotor lid, aluminum, aerosol-tight, angle 45°, 24 places, max. diameter 11 mm, designed for 1.5/2.0 ml micro test tubes	5424 702.007	022653008
Spare lid (aluminum) for rotor FA-45-24-11, aerosol-tight	5424 703.003	022653024
Fixed-angle rotor FA-45-24-11-Special with rotor lid, aluminum, aerosol-tight, coated angle 45°, 24 places, max. diameter 11 mm, designed for 1.5/2.0 ml micro test tubes	5424 700.004	022653041
Spare lid (aluminum) for rotor FA-45-24-11-Special, aerosol-tight, coated	5424 701.000	022653067

## 7 Ordering information

	Order no. International	Order no. North America
Fixed-angle rotor F-45-18-11-Kit with rotor lid, aluminum, angle 45°, 18 places, max. diameter 11 mm, designed for 1.5/2.0 ml micro test tubes	5424 706.002	022653083
Spare lid (polypropylene) for rotor F-45-18-11-Kit	5424 707.009	022653105
Fixed-angle rotor F-45-32-5-PCR with rotor lid, aluminum, angle 45°, 32 places, max. diameter 5 mm, designed for 0.2 ml PCR tubes	5424 704.000	022653121
Spare lid (aluminum) for rotor F-45-32-5-PCR	5424 708.005	022653148
<b>Accessories</b>		
Adapter for 0.2 ml PCR tubes, for FA-45-24-11, FA-45-24-11-Special and F-45-24-11-Kit, per 6 pcs	5425 715.005	022636260
Adapter for 0.4 ml micro test tubes, for FA-45-18-11, FA-45-18-11-Special and F-45-24-11-Kit, per 6 pcs	5425 717.008	022636243
Adapter for 0.5 ml micro test tubes and 0.6 ml Microtainers <sup>®</sup> , for FA-45-18-11, FA-45-18-11-Special and F-45-24-11-Kit, per 6 pcs	5425 716.001	022636227
Rotor key	5416 301.001	022634305
Captain Eppi, rotor key holder, 1 pc	5703 350.102	022639609
Set of fuses      2 x 2.5 AT (230 V)	5425 351.003	022668188
2 x 5.0 AT (120 V / 100 V)	5425 353.006	022668226

### Rotor code

All Eppendorf rotors are designated according to a simple, logical system which describes the technical specifications as a uniform series of numbers and letters e.g.:

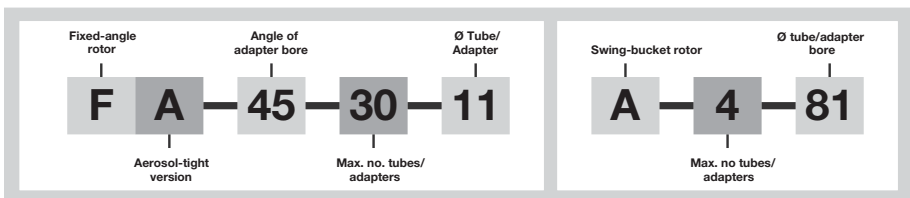

## 7 Ordering information

### Important

Use only the original accessories we recommend. The functioning and safety of centrifuges may be impaired if you use spares or disposables other than those we recommend! Any warranty and liability for losses thus caused shall be excluded.

Bacilloj <sup>®</sup> AF	Registered trade mark of Bode Chemie GmbH & Co., Hamburg, Germany
Extran <sup>®</sup> neutral	Registered trade mark of Merck KGaA, Darmstadt, Germany
Meliseptol <sup>®</sup>	Registered trade mark of B. Braun Melsungen AG, Melsungen, Germany
Microtainer <sup>®</sup>	Registered trade mark of Becton Dickinson, Franklin Lakes, USA
Perform <sup>®</sup>	Registered trade mark of Schülke & Mayr GmbH, Norderstedt, Germany
RBS <sup>®</sup> neutral	Registered trade mark of Carl Roth GmbH + Co. KG, Karlsruhe, Germany
Teepol <sup>®</sup> 610 S	Registered trade mark of Sigma-Aldrich Corp., St. Louis, USA

# EG-Konformitätserklärung EC Conformity Declaration

Das bezeichnete Produkt entspricht den einschlägigen grundlegenden Anforderungen der aufgeführten EG-Richtlinien und Normen. Bei einer nicht mit uns abgestimmten Änderung des Produktes oder einer nicht bestimmungsgemäßen Anwendung verliert diese Erklärung ihre Gültigkeit.

The product named below fulfills the relevant fundamental requirements of the EC directives and standards listed. In the case of unauthorized modifications to the product or an unintended use this declaration becomes invalid.

Produktbezeichnung, Product name:

Centrifuge 5424

einschließlich Zubehör / including accessories

Produkttyp, Product type:

Laborzentrifuge / Laboratory Centrifuge

Einschlägige EG-Richtlinien/Normen, Relevant EC directives/standards:

73/23/EWG, EN 61010-1, EN 61010-2-20

89/336/EWG, EN 55011/B, EN 61000-6-1, EN 61000-3-2, EN 61000-3-3, EN 61326

98/37/EG, EN 292-2, EN 292-2/A1,

98/79/EG, EN 14971, EN 61010-2-101

Vorstand, Board of Management:

15.06.2005

Hamburg, Date:

Projektmanagement, Project Management:



**eppendorf**

Eppendorf AG · Barkhausenweg 1 · 22339 Hamburg · Germany

# Certificate of Compliance

Certificate Number 150705 - E215059  
Report Reference E215059, June 21st, 2005  
Issue Date 2005 July 15

Page 1 of 1



*Issued to:* **EPENDORF AG**  
**BARKHAUSENWEG 1**  
**22339 HAMBURG GERMANY**

*This is to certify that representative samples of* **Centrifuge**  
**Model 5424**

*Have been investigated by Underwriters Laboratories Inc.® in accordance with the Standard(s) indicated on this Certificate.*

*Standard(s) for Safety:*

UL 61010A-1 - Electrical Equipment for Laboratory Use; Part 1  
UL 61010A-2-020 - Part 2: Particular Requirements for Laboratory Centrifuges  
CSA C22.2 No. 1010.1-92 - Safety Requirements for Electrical Equipment for Measurement, Control and Laboratory Use;  
Part 1: General Requirements  
CSA C22.2 No.1010.2-020-92, CSA C22.2 No. 1010.2-020A-97Part 2:Part Requirements for Laboratory Centrifuges

*Additional Information:*

**ELECTRICAL RATING:**  
Voltage: 120 V ac  
Frequency: 50-60 Hz  
Current: 3.8 A  
Power: 220 W

Only those products bearing the UL Listing Mark for the US and Canada should be considered as being covered by UL's Listing and Follow-Up Service meeting the appropriate requirements for US and Canada.

The UL Listing Mark for the US and Canada generally includes: the UL in a circle symbol with "C" and "US" identifiers;  the word "LISTED"; a control number (may be alphanumeric) assigned by UL; and the product category name (product identifier) as indicated in the appropriate UL Directory.

**Look for the UL Listing Mark on the product**

Issued by: *Walter Hofmair*  
**Walter Hofmair, Senior Project Engineer**





UL International Germany GmbH

Any information and documentation provided to you involving UL Mark services are provided on behalf of Underwriters Laboratories Inc.  
For questions in Germany, you may call +49 0 61 02 369 0.

Reviewed by: *Manfred Müller*  
**Manfred Müller, Senior Project Engineer**

UL International Germany GmbH

## Menu structure / Menüstruktur

M1	M2		
BACK			
SOFT	BACK ON OFF		see Section 3.11 / siehe Kapitel 3.11
ALARM	BACK ON OFF	 	see Section 3.14 / siehe Kapitel 3.14
ATSET	BACK ON OFF		see Section 3.12 / siehe Kapitel 3.12
SHORT	BACK MAX SHORT		see Section 3.8 / siehe Kapitel 3.8
SLEEP	BACK ON OFF		see Section 3.16 / siehe Kapitel 3.16
LOCK	BACK ON OFF		see Section 3.13 / siehe Kapitel 3.13
VOL	BACK VOL1 VOL2 VOL3 VOL4 VOL5		see Section 3.15 / siehe Kapitel 3.15

# Eppendorf Offices

## ASEAN

Eppendorf AG  
Regional Office in Malaysia  
Tel. +60 3 8023 2769  
Fax +60 3 8023 3720  
E-Mail: eppendorf@eppendorf.com.my  
Internet: www.eppendorf.com.my

## AUSTRALIA / NEW ZEALAND

Eppendorf South Pacific Pty. Ltd.  
Tel. +61 2 9889 5000  
Fax +61 2 9889 5111  
E-mail: Info@eppendorf.com.au  
Internet: www.eppendorf.com.au

## AUSTRIA

Eppendorf AG  
c/o Schott Austria  
Tel. +43 1 29017560  
Fax +43 1 290175620  
E-Mail: gilch.p@eppendorf.de  
Internet: www.eppendorf.com

## Brazil

Eppendorf do Brasil Ltda.  
Tel. +55 11 30 95 93 44  
Fax +55 11 30 95 93 40  
E-Mail: eppendorf@eppendorf.com.br  
Internet: www.eppendorf.com.br

## CANADA

Brinkmann Instruments, Ltd.  
Tel. +1 905 826 5525  
Fax +1 905 826 5424  
E-Mail: canada@brinkmann.com  
Internet: www.brinkmann.com

## CHINA

Eppendorf AG  
Tel. +86 21 68760880  
Fax +86 21 50815371  
E-Mail: market.info@eppendorf.cn  
Internet: www.eppendorf.cn

## FRANCE

EPPENDORF FRANCE S.A.R.L.  
Tel. +33 1 30 15 67 40  
Fax +33 1 30 15 67 45  
E-Mail: eppendorf@eppendorf.fr  
Internet: www.eppendorf.fr

## GERMANY

Eppendorf Vertrieb  
Deutschland GmbH  
Tel. +49 2232 418-0  
Fax +49 2232 418-155  
E-Mail: vertrieb@eppendorf.de  
Internet: www.eppendorf.de

## INDIA

Eppendorf India Limited  
Tel. +91 44 52111314  
Fax +91 44 52187405  
E-Mail: info@eppendorf.co.in  
Internet: www.eppendorf.co.in

## ITALY

Eppendorf s.r.l.  
Tel. +390 2 55 404 1  
Fax +390 2 58 013 438  
E-Mail: eppendorf@eppendorf.it  
Internet: www.eppendorf.it

## JAPAN

Eppendorf Japan Co. Ltd.  
Tel. +81 3 5825 2363  
Fax +81 3 5825 2365  
E-Mail: info@eppendorf.jp  
Internet: www.eppendorf.jp

## NORDIC

Eppendorf Nordic Aps  
Tel. +45 70 22 2970  
Fax +45 45 76 7370  
E-Mail: nordic@eppendorf.dk  
Internet: www.eppendorf.dk

## SPAIN

Eppendorf Ibérica S.L.  
Tel. +34 91 651 76 94  
Fax +34 91 651 81 44  
E-Mail: iberica@eppendorf.de  
Internet: www.eppendorf.es

## SWITZERLAND

Vaudaux-Eppendorf AG  
Tel. +41 61 482 1414  
Fax +41 61 482 1419  
E-Mail: vaudaux@vaudaux.ch  
Internet: www.eppendorf.com

## UNITED KINGDOM

Eppendorf UK Limited  
Tel. +44 1223 200 440  
Fax +44 1223 200 441  
E-Mail: sales@eppendorf.co.uk  
Internet: www.eppendorf.co.uk

## USA

Eppendorf North America  
Tel. +1 516 334 7500  
Fax +1 516 334 7506  
E-Mail: info@eppendorf.com  
Internet: www.eppendorfna.com

## OTHER COUNTRIES

see:  
www.eppendorf.com/worldwide

# eppendorf

*In touch with life*

**Your local distributor: [www.eppendorf.com/worldwide](http://www.eppendorf.com/worldwide)**

Eppendorf AG · 22331 Hamburg · Germany · Tel. +49 40 5 38 01-0 · Fax +49 40 5 38 01-556  
E-Mail: [eppendorf@eppendorf.com](mailto:eppendorf@eppendorf.com)

Eppendorf North America, Inc. · One Cantiague Road, P.O. Box 1019 · Westbury, N.Y. 11590-0207 USA  
Tel. +1 516 3 34 75 00 · Toll free phone 800 6 45 30 50 · Fax +1 516 3 34 75 06 · E-Mail: [info@eppendorf.com](mailto:info@eppendorf.com)

## **Application Support**

Europe, International: Tel. +49 180 3 66 67 89 · E-Mail: [support@eppendorf.com](mailto:support@eppendorf.com)  
North America: Tel. +1 800 6 45 30 50 ext. 2258 · E-Mail: [support\\_NA@eppendorf.com](mailto:support_NA@eppendorf.com)  
Asia, Pacific: Tel. +60 3 80 23 27 69 · E-Mail: [support\\_Asia@eppendorf.com](mailto:support_Asia@eppendorf.com)