

## LAMINAR FLOW FAN/FILTER MODULES

Rev 1. 11/03

### S-RANGE

A versatile and effective air cleaner in a wide variety of applications, the fan filter module is available in a range of sizes. Each is fully self-contained with its own pre-filter, HEPA filter and air distribution fan internally controllable to permit compensation for increasing resistance across the HEPA filter.

Standard finishes include:

Stainless Steel

Powder Coated Mild Steel

Laminated

Conforms to:

BSEN ISO 14644-1 (Class 4 & 5)



### SPECIFICATION

Model	S2	S3	S4	S5	S6
Width	660	965	1270	1575	1880
Depth	660	660	660	660	660
Height	455	455	455	455	455
Weight	45kg	56kg	67kg	83kg	96kg
Air Velocity (face)					
m3/sec @ 0.45m/sec	0.15	0.23	0.31	0.39	0.47
CUft/min @ 90ft/min	320	490	660	830	1000

### DETAIL

#### Legend

1. Xxx
2. Xxx
3. Xxx
4. Xxx
5. Xxx
6. Xxx

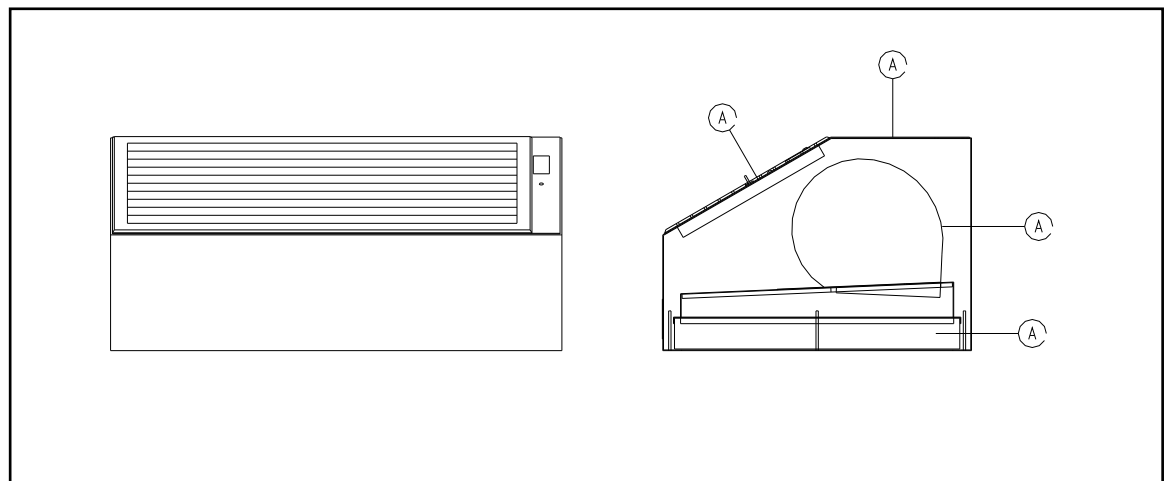

## LAMINAR FLOW FAN/FILTER MODULES

Rev 1. 11/03

### FEATURES

Pre-Filter:	92% efficient at 5.0 micron
HEPA Filter:	99.999% efficient at 0.3 micron
ULPA Filter:	99.9999% efficient at 0.12 micron
Air Velocity:	To any configuration required
Operating Resistance:	Maximum 230Pa
Electrical Supply:	230-240V 50/60Hz single phase S2-S4: 500watts S5-S6: 1000watts All models are PAT 60 tested and have individual fused protection
Fan(s):	Double inlet, centrifugal, super silent and thermally protected
Controls:	Internally mounted, variable speed controller and fuse protected Air Velocity indicator
Noise Level:	58-63db (A) at normal levels of between 35-40db (A) measured at 1m from filter face at ambient noise level db (A) 2
Lighting:	1000-lux minimum at work surface
Structure:	High quality mild steel powder coated white User access to pre-filter through spring loaded anodised aluminium grille



### OPTIONAL FEATURES

- ULPA filtration
- Air Velocity or pressure meter with audible and visible alarms
- Adaptation to accept ductwork containing air heating/cooling equipment
- Top or side mounting brackets
- Flexible anti-static PVC curtaining
- Full installation services

#### Other Products & Services

- Full design, build, installation and maintenance of Cleanroom facilities
- Portable and Temporary Clean Air Facilities
- Modular Fan/Filter Units for Cleanroom applications
- Comprehensive range of Laminar Flow equipment
- Microbiological Safety Cabinets
- Mobile Clean Air Enclosures
- Containment Isolators and facilities

#### Preventative Maintenance

Bassaire offers competitive maintenance and re-validation services on all makes of clean air equipment.

#### Guarantee

All Bassaire equipment is designed, constructed and inspected to the highest standards and specifications, to give long and reliable service, and is supported with a fully comprehensive one-year parts and labour warranty.

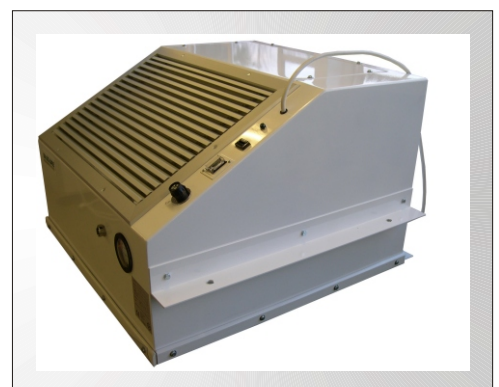

STANDARDS CONFORM TO:

BSEN ISO 14644-1  
(CLASS 4 & 5)